

BL30D BELT LOADER

OPERATION, MAINTENANCE AND PARTS MANUAL



Published in Canada by Avro GSE™ Limited.

All possible care has been taken in the preparation of this manual, but Avro GSE, its agents and distributors accept no liability for any inaccuracies that may be found. This manual reflects the state of the product at its date of issue, but further enhancements while in service may mean that the manual does not precisely reflect your system.

Avro GSE reserves the right to make changes without notice both to this manual and the products which it describes.

Avro GSE shall not be liable for errors contained herein or for incidental or consequential damages in connection with the furnishing, performance, or use of this manual.

Copyright: © Avro GSE™ 2025

All rights reserved.

No part of this publication may be reproduced, stored in a retrieval system, or transmitted in any form or by any means electronic, mechanical, photocopying, recording or otherwise without the express prior written permission of the copyright holder.

Avro GSE™ is a registered Trademark of Avro GSE™.

All trademarks used within this document are the property of their respective owners.

CONTACT DETAILS.

If you require technical assistance with this product that is not covered within this manual, then help can be requested from Avro GSE using the contact details given below, or from our distribution partners.



Address:

Avro GSE
865 Prospect Ave.
Oxbow, Saskatchewan
Canada S0C 2B0



Phone: +1 833 220 2810



Email: parts@avrogse.com

service@avrogse.com

Website: www.avrogse.com

APPLICABILITY OF THIS MANUAL

BL30D Belt Loaders with a Manufacture Year of 2022 (MY2022) Serial Numbers SN222231682+.

If this manual does not correspond to the Manufacture Year (MY) of your Belt Loader, the correct manual can be obtained from AvroGSE using the contact details given inside the Front Cover of this manual.

Manual Part Number: PRPW03218

PAGE INTENTIONALLY LEFT BLANK

TABLE OF CONTENTS

APPLICABILITY OF THIS MANUAL	3
TABLE OF CONTENTS	5
LIST OF ABBREVIATIONS	8
SAFETY	9
LETHAL DANGER – CARGO USE ONLY	9
LETHAL DANGER – DO NOT USE ON PUBLIC ROADS	9
LETHAL DANGER – DO NOT ALTER FACTORY SETTINGS	9
FATAL WARNING – CRUSH INJURY	9
WARNING – PETROLEUM – FIRE AND HEALTH HAZARD	10
WARNING – BURN HAZARD	10
WARNING – MAXIMUM SPEED	10
WARNING – ALCOHOL AND DRUG USE	10
WARNING – SIZE AND WEIGHT OF BELT LOADER	10
WARNING – DO NOT LIFT BELT LOADER WITH A FORKLIFT	11
WARNING – HEAVY ITEMS	11
WARNING – PETROLEUM, OILS AND LUBRICANTS	11
WARNING – DAMAGE TO HYDRAULIC SYSTEM	11
PRECAUTION – PERSONAL PROTECTIVE EQUIPMENT	11
PRECAUTION - READ THIS MANUAL	12
PRECAUTION – OPERATOR TRAINING	12
PRECAUTION – SAFE WORKING PRACTICES	12
WARNINGS AND PRECAUTIONS – WELDING, GRINDING, AND CUTTING	13
INTRODUCTION	15
SPECIFICATION	16
DESCRIPTION	19
LETHAL DANGER – DO NOT ALTER FACTORY SETTINGS	26
START-UP	30
WARNING – DAMAGE TO HYDRAULIC SYSTEM	30
OPERATION	32
FATAL WARNING – CRUSH INJURY	32
WARNING – DAMAGE TO AIRCRAFT	32
WARNING – USE HANDRAIL	33
WARNING – CONVEYOR BELT	34
WORKING UNDER THE BELT FRAME ASSEMBLY	35

FATAL WARNING – CRUSH INJURY	35
FUNCTIONAL DESCRIPTION OF MAIN ASSEMBLIES	37
REFUELLING	41
WARNING – PETROLEUM – FIRE AND HEALTH HAZARD	41
STORAGE	42
RECEIPT AND PREPARATION FOR FIRST USE	42
MANUAL EMERGENCY OPERATION INSTRUCTIONS	43
FATAL WARNING – CRUSH INJURY	44
FATAL WARNING – CRUSH INJURY	45
TOWING INSTRUCTIONS	45
SCHEDULED MAINTENANCE	46
WARNING – COMPRESSED AIR	46
WARNING – BURN HAZARD	48
PRECAUTION – LIFE OF HIGH-PRESSURE HYDRAULIC HOSES	53
COLD/HOT WEATHER MAINTENANCE	53
WHEEL NUT TIGHTENING	54
FUEL, LUBRICANTS AND CONSUMABLES	55
LUBRICATION DIAGRAM	58
WARNING – PETROLEUM, OILS AND LUBRICANTS	61
PRECAUTION – CONTAMINATION OF HYDRAULIC SYSTEM	62
WARNING – COMPRESSED AIR	65
TROUBLESHOOTING AND FAILURE DIAGNOSIS	67
REPAIR	77
WARNINGS AND PRECAUTIONS – WELDING, GRINDING, AND CUTTING	79
ELECTRICAL SCHEMATICS	81
HyDRAULIC SCHEMATIC	90
EXPLODED PARTS VIEWS & PARTS LISTS	93
BODY & EXTERIOR	94
SEATS	102
BELT FRAME ASSEMBLY	110
CONTROLS AND INSTRUMENTS	126
ELECTRICAL SYSTEM	130
ENGINE MOUNTING	142
COOLING SYSTEM	148
FUEL SYSTEM	150
EXHAUST SYSTEM	152

TRANSMISSION MOUNTING	154
DRIVETRAIN	156
BRAKING SYSTEM	166
STEERING SYSTEM	170
HYDRAULIC SYSTEM	178
WHEELS & TIRES	190
LABELS	194
SUPPLEMENTARY INFORMATION	197
LIFTING/SHIPPING THE BL30D Belt Loader	198
WARNING – SIZE AND WEIGHT OF BELT LOADER	199
WARNING – LIFTING OPERATIONS	199
WARNING – DO NOT LIFT A BELT LOADER WITH A FORKLIFT	199
WARRENTY	200
DISPOSAL	200
APPENDICES	201
OKAMURA TRANSMISSION SERVICE MANUAL – Y43340D, Y43290D, AND Y43370D	201

LIST OF ABBREVIATIONS

A	Amp (Ampere)	LED	light emitting diode
C	Centigrade	Max	maximum
cc	cubic centimetres	MIL	Malfunction Indicator Lamp
c/w	complete with	mm	millimetres
DBP	Draw bar Pull	MPa	Megapascal (1 MPa = 1 Nmm ² = 145 lbs/in ²)
Deg	degree (temperature)	mph	miles per hour
Dia.	diameter	MY	manufacture year
D.T.C.	Diagnostic Trouble Code	N/A	Not Applicable
F	Fahrenheit	Nm	Newton Metre
ft/lbs	foot-pounds force	o.d.	outside diameter
GSE	ground support equipment	P/N	Part Number
kg	kilograms	PPE	Personal Protective Equipment
IATA	International Air Transport Association	psi	pounds per square inch (pressure)
i.d.	inside diameter	SAE	Society of Automotive Engineers (specification)
in.	Inches	SWL	Safe Working Load
kph	kilometres per hour	Temp	temperature
L	litre	Turbo	turbocharger
lbs	pounds		

SAFETY

Observe the following safety precautions.

LETHAL DANGER – CARGO USE ONLY



The Belt Loader is designed for airport luggage and cargo handling only. Do not exceed the Belt Loaders' weight handling capacity. It is dangerous to do so and an accident or damage to the Belt Loader may result.

Other than the driver, **DO NOT** allow people to ride on the Belt Loader. It is unsafe to do so, and lethal injury may result.

LETHAL DANGER – DO NOT USE ON PUBLIC ROADS



The Belt Loader is designed for use in airports. It is **NOT** suitable, or legal, for use on public roads. Attempting to use the Belt Loader on a public road may result in a lethal accident.

DO NOT use the Belt Loader for purposes for which it was not designed. **DO NOT** operate the Belt Loader in a reckless manner. Lethal injury may result.

LETHAL DANGER – DO NOT ALTER FACTORY SETTINGS



DO NOT attempt to alter the Belt Loader's factory settings. Lethal injury may result. The factory settings optimise both the safety and performance of the Belt Loader.

Altering the factory settings invalidates the Warranty on the Belt Loader.

FATAL WARNING – CRUSH INJURY



It is strictly forbidden to stand or sit under the Belt Frame Assembly when it is in the raised position. Do not place hands, arms, legs, or feet under the Belt Frame Assembly when it is in the raised position. A hydraulic failure, or unintended movement of the Belt Frame Assembly, can cause serious or fatal injury.

Make sure that no person or object is near or under the Belt Frame when it is lowered. A crush injury from the Belt Frame will cause serious or fatal injury.

Before performing maintenance or servicing beneath the Belt Frame Assembly when it is in the raised position, lock the Belt Frame Assembly in the raised position with the Safety Prop and the Belt Frame Locking Pin. A hydraulic failure, or unintended movement of the Belt Frame Assembly, can cause serious or fatal injury.

WARNING – PETROLEUM – FIRE AND HEALTH HAZARD



Fuel expands when heated. Expanding fuel in an over full tank can cause spills and leaks. Do not overfill the fuel tank.

Do not eat, drink or smoke when refuelling the Belt loader. If fuel is ingested, or comes into contact with your eyes, nose or mouth, seek medical assistance immediately.

Fuel spillages are a fire and slip hazard. Always clean up any spillages.

WARNING – BURN HAZARD



Hot water in the radiator will scald. Make sure that the engine has cooled down before removing the radiator cap. Wear Personal Protective Equipment (PPE) including eye shields or protective goggles, and suitable protective gloves.

WARNING – MAXIMUM SPEED



The maximum speed of the Belt Loader is limited to 25 kph (15.5 mph). It is unsafe to exceed that speed.

Do not attempt to modify the Belt Loader to exceed that speed. A fatal accident may result.

WARNING – ALCOHOL AND DRUG USE



The Belt Loader must not be accessed or operated by anyone impaired by alcohol or drugs.

WARNING – SIZE AND WEIGHT OF BELT LOADER



The Belt Loader is 8.1 m (26 ft 6.9 in.) long and weighs 4200 kg (9260 lbs). When lifting the Belt Loader, always use a crane and a four-leg lifting sling or chain with a Safe Working Load (SWL) of at least 7000 kg (7 Tons). Always attach the four - leg lifting sling or chain to the four lifting points on the Belt Loader.

The Belt Loader must always be towed or moved using a suitable vehicle.

WARNING – DO NOT LIFT BELT LOADER WITH A FORKLIFT



The Belt Loader is 8.1 m (26 ft 6.9 in.) long and weighs 4200 kg (9260 lbs). Due to the length of the Belt Loader, **DO NOT** use a forklift truck to lift the Belt Loader.

WARNING – HEAVY ITEMS



Always use correct manual handling techniques. For items positioned below mid-lower leg height, safe lifting capacity is 10 kg (5 kg if not close to your feet) for an able-bodied man and 7kg (3 kg if not close to your feet) for an able-bodied woman.

WARNING – PETROLEUM, OILS AND LUBRICANTS



Do not eat, drink or smoke when applying oil or lubricant. Do not allow the lubricant to come into contact with your eyes, mouth or nose. Wear Personal Protective Equipment (PPE), for example suitable gloves, eye shields, and overalls. If lubricant is ingested, or comes into contact with your eyes, seek medical assistance immediately.

Oil and lubricants are a slip hazard. Always clean up any spillages, or excess oil or lubricant.

WARNING – DAMAGE TO HYDRAULIC SYSTEM



Before using the vehicle, at the start of every shift, check the Oil Return Filter pressure gauge. Make sure that the pressure gauge needle is in the green area. If the needle is **NOT** in the green area **DO NOT** use the vehicle, **SWITCH OFF** the vehicle, and report the problem. The filter element located inside the Oil Return Filter, **MUST** be removed, cleaned, and refitted **BEFORE** using the vehicle.

PRECAUTION – PERSONAL PROTECTIVE EQUIPMENT



When operating, moving, lifting, servicing, repairing, or transporting the Belt Loader, always wear suitable Personal Protective Equipment (PPE) to prevent crushing of hands, feet, or other body parts. For example, wear protective footwear, safety glasses, hard hat, protective gloves, and high-visibility clothing.

When preparing the Belt Loader for transport by air, road, or rail, make sure it is securely packed. Safeguard the Belt Loader against movement or break-

away during transport by applying the brake, and securely strapping the Belt Loader in place.

PRECAUTION - READ THIS MANUAL



Read and understand this manual before operating, cleaning, repairing, or servicing the Belt Loader.

A copy of this manual will have been provided with each Belt Loader when it was delivered.

Familiarize yourself with the location and correct use of all controls, indicators, and safety devices before operating the Belt Loader.

PRECAUTION – OPERATOR TRAINING



ONLY people who have been **FULLY TRAINED AND AUTHORIZED** to operate this type of Belt Loader are permitted to start, operate, and shut down the Belt Loader.

Anyone operating or maintaining the Belt Loader must understand the potential risks and hazards associated with it **BEFORE** they operate the Belt Loader.

Anyone operating or maintaining the Belt Loader must be familiar with all the required safety devices and procedures.

PRECAUTION – SAFE WORKING PRACTICES



Be aware of the Belt Loader's working parts. Keep hands, feet, and loose clothing away from the Belt Loader's moving parts.

DO NOT operate a Belt Loader that is need of repair. Perform scheduled maintenance in accordance with the maintenance procedures given in this manual.

Only operate the Belt Loader when:

- (1) All safety devices and guards are in place and in full working order.
- (2) All controls, gauges, lights, and indicators operate correctly.
- (3) The Belt Loader is set-up correctly in accordance with this manual.

WARNINGS AND PRECAUTIONS – WELDING, GRINDING, AND CUTTING



WELDING ARC. A welding arc is bright enough to damage eyesight and cause flash burns. Never look directly at a welding arc with unprotected eyes. Always use an approved welding screen or visor. Cover all exposed skin before welding.



PROTECTIVE CLOTHING. Always wear protective clothing and gloves appropriate for welding work.



HOT WELDS. Always allow a weld to cool before removing welding slag.

Make sure that there is no combustible material within 4 Meters (13 feet) of grinding, welding, or slag chipping.



GRINDING, CHIPPING, AND CUTTING. Always wear eye protection (e.g. protective goggles) when using grinding and cutting tools, and when chipping off welding slag. Always wear eye protection when within 4 Meters (13 feet) of grinding, slag chipping, or cutting with power tools.



DAMAGE TO ELECTRICAL EQUIPMENT. To prevent damage to the vehicle electrical system, before performing any welding, remove or disconnect all vehicle batteries, and disconnect all electrical connections to the vehicle electronics.



TRAINING, AUTHORIZATION AND CERTIFICATION OF WELDERS. Welding must only be performed by people who have been **FULLY TRAINED IN WELDING AND ARE AUTHORIZED** to perform welding operations. Welders must be **CERTIFIED** by their respective national association of welders, such as CWB and/or AWS.

Grinding, chipping, and cutting with power tools must only be performed by people who have been **FULLY TRAINED IN USING THE POWER TOOLS AND ARE AUTHORIZED** to perform those operations.

Before performing any welding, grinding or chipping operations, make sure that any necessary Hot Work Permits have been obtained.

PAGE INTENTIONALLY LEFT BLANK

INTRODUCTION

The function of the BL30D Belt Loader vehicle is to transfer passenger baggage and other light cargo from baggage carts and cargo dollies to the baggage/cargo holds on aircraft.



Figure 1 – BL30D Belt Loader

The BL30D is a rear-wheel-drive vehicle, powered by a 1.861 Litre diesel engine, with an open-top drivers' compartment. The baggage/cargo transfer is done by a conveyor belt whose position can be hydraulically adjusted to match the height above the ground of the aircraft hold. The conveyor belt is lowered to a near horizontal position when moving the vehicle.

SPECIFICATION

The specification of the BL30D Belt Loader is given in the following Table.

Table 1 BL30D Belt Loader specification

B:30G Belt Loader	Value	Units	Notes
Dimensions			
Length (overall)	8100 318.9	mm in.	With Belt Frame Assembly in the fully lowered position.
Width (mirrors folded in)	2140 84.3	mm in.	
Height (maximum)	4560 179.5	mm in.	With Belt Frame Assembly at an angle of 25 deg. to top of cab.
Height (minimum, to top of warning beacon on drivers' cab)	1965 77.4	mm in.	
Wheelbase	2990 117.7	mm in.	
Minimum Ground Clearance	150 5.9	mm in.	
Front overhang	1280 50.4	mm in.	
Rear overhang	800 31.5	mm in.	
Front Approach Angle (maximum)	16	degrees	
Rear Departure Angle (maximum)	17	degrees	
Service Weight	4200 9260	kg lbs	
Maximum Travel Speed	15.5 25.0	mph kph	Forward speed.
Maximum gradient (that can be climbed)	15	%	
Engine type	Diesel		Model Cummins QSF2.8
	1.861	L	Model Cummins QSF2.8
Engine Total Displacement	42/2600 56.3/2600	kW/rpm HP/rpm	Model Cummins QSF2.8
	225/1500 165.9/1500	Nm/rpm lbf ft/rpm	Model Cummins QSF2.8
Engine Rated Power Output and Speed	137.1/1100-1500		Cummins QSF2.8)

B:30G Belt Loader		Value	Units	Notes
Engine Rated Torque and Speed				Naturally aspirated (Model Cummins QSF2.8)
			Model No.	Automatic Manufacturer: Okamura
Throttle control		Y43280D	2.178	
Air intake		Forward	2.235	
		Reverse		Hydraulic power steering
Transmission Type				Vacuum assisted hydraulic brakes
Gear ratios			Manual	
		mm in.	With Belt Frame Assembly at an angle of 25 deg. to top of cab.	
Steering		1100 - 4560 43.1 - 179.5	mm in.	
Foot Brake		540 - 1650 21.3 - 65.0	mm in.	On flat, level, ground.
Park Brake		4560 179.5	mm in.	On flat, level, ground.
Conveyor belt front height range		1100 43.3	degrees	
Conveyor belt rear height range		30	mm in.	
Maximum baggage loading height		600 23.6	m/sec ft/sec	
Minimum baggage loading height		0.2 to 0.5 0.66 to 1.64	kg lbs.	This weight must not be exceeded
Maximum conveyor belt angle		1000 2204	kg lbs.	This weight must not be exceeded
Conveyor belt width		400 882	deg C	Ambient temperature
Conveyor belt speed		-30 to +50	deg F	
Maximum weight on conveyor belt		-22 to +122	deg C	Ambient temperature

B:30G Belt Loader	Value	Units	Notes
Maximum single item weight on conveyor belt	-30 to +50	deg F	Storage indoors recommended
Operating temperature range	-22 to +122	%	Relative humidity
	0 to 100		
Storage temperature range	225/70R15		
	225/70R15	Bar (gauge)	
Humidity range	5 ± 0.21	psi	
Front Tires	72.5 ± 3	MPa	
Rear Tires	0.5 ± 0.021		
Tire pressures (all tires)			

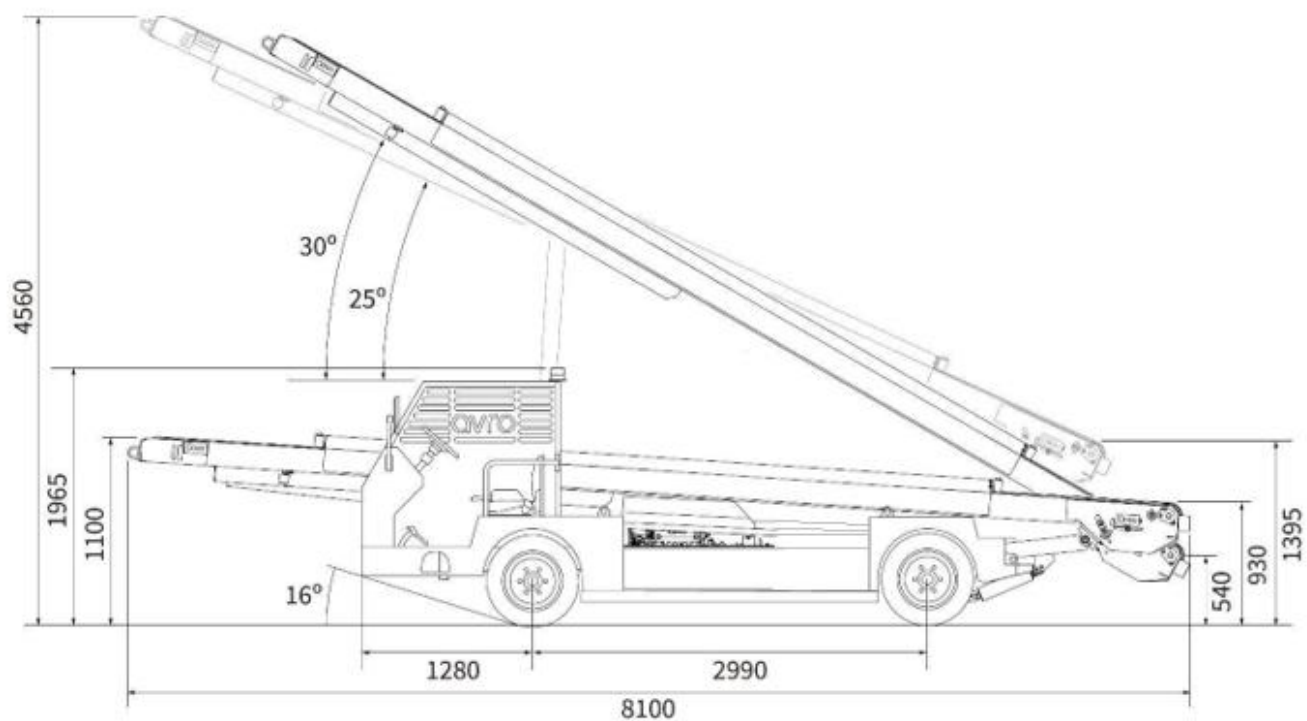
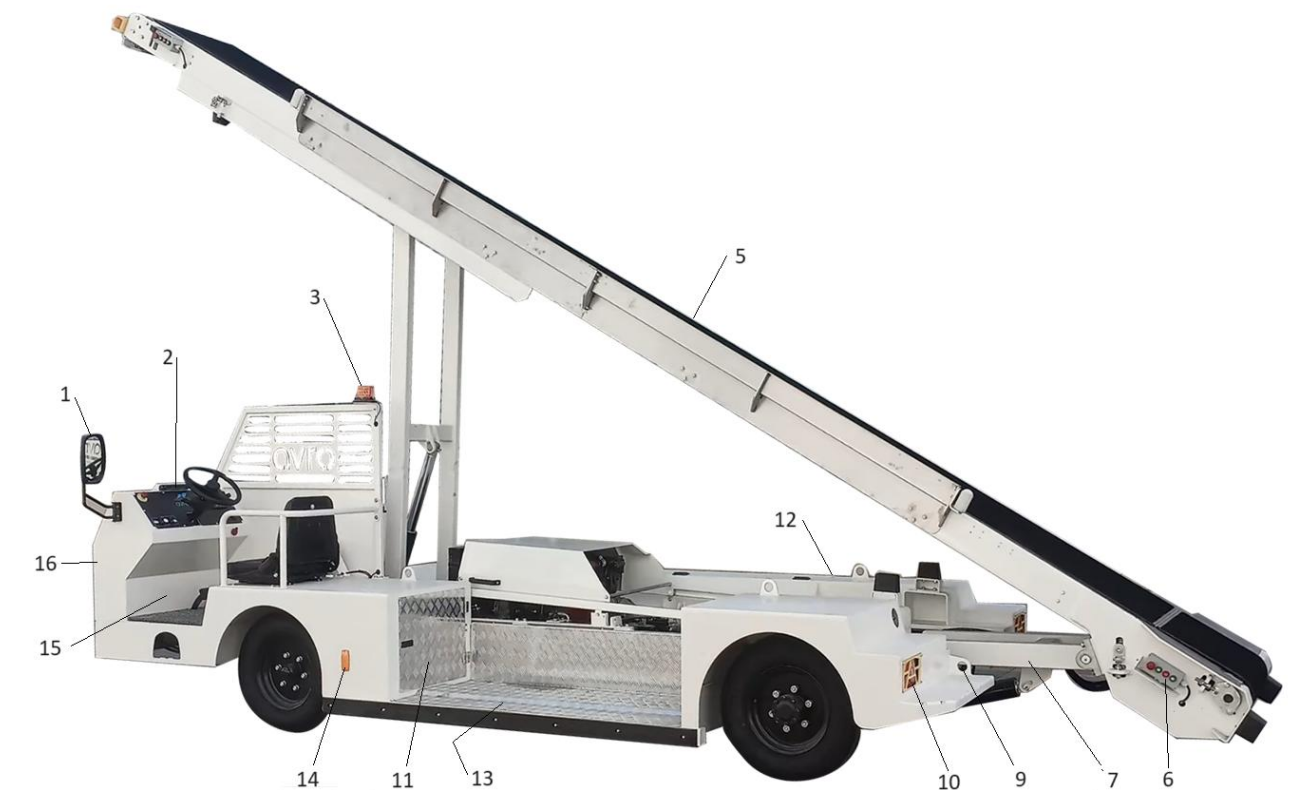

Figure 2 – BL30D Belt Loader dimensions

DESCRIPTION



- | | | | |
|---|---------------------------------|----|--------------------------------------|
| 1 | Wing (side View) Mirror | 9 | Rear towing lug |
| 2 | Drivers Instrument Panel (Dash) | 10 | Rear indicator lights |
| 3 | Warning Beacon | 11 | Battery Compartment |
| 4 | Engine Cover Panel | 12 | Fuel Tank compartment |
| 5 | Belt | 13 | Storage area |
| 6 | Belt Control Box | 14 | Turn Indicator |
| 7 | Rear Lifting Frame | 15 | Drivers' compartment |
| 8 | Rear Lift Cylinder | 16 | Steering Gear/Electrical Compartment |

Figure 3 – BL30D Belt Loader (left rear view)



- | | | | |
|---|-------------------------|----|---------------------------------------|
| 1 | Luggage Rail | 8 | Hydraulic Oil tank (inside) |
| 2 | Belt Frame Assembly | 9 | Fuel fill point |
| 3 | Handrail Assembly | 10 | Engine |
| 4 | Front Lifting Frame | 11 | Transmission |
| 5 | Front Lift Cylinder | 12 | Hydraulic Motor (for Rear Drive Drum) |
| 6 | Wing (side View) Mirror | 13 | Rear Drive Drum |
| 7 | Hydraulic Compartment | 14 | Fuel Tank Compartment |

Figure 4 – BL30D Belt Loader (right rear view)

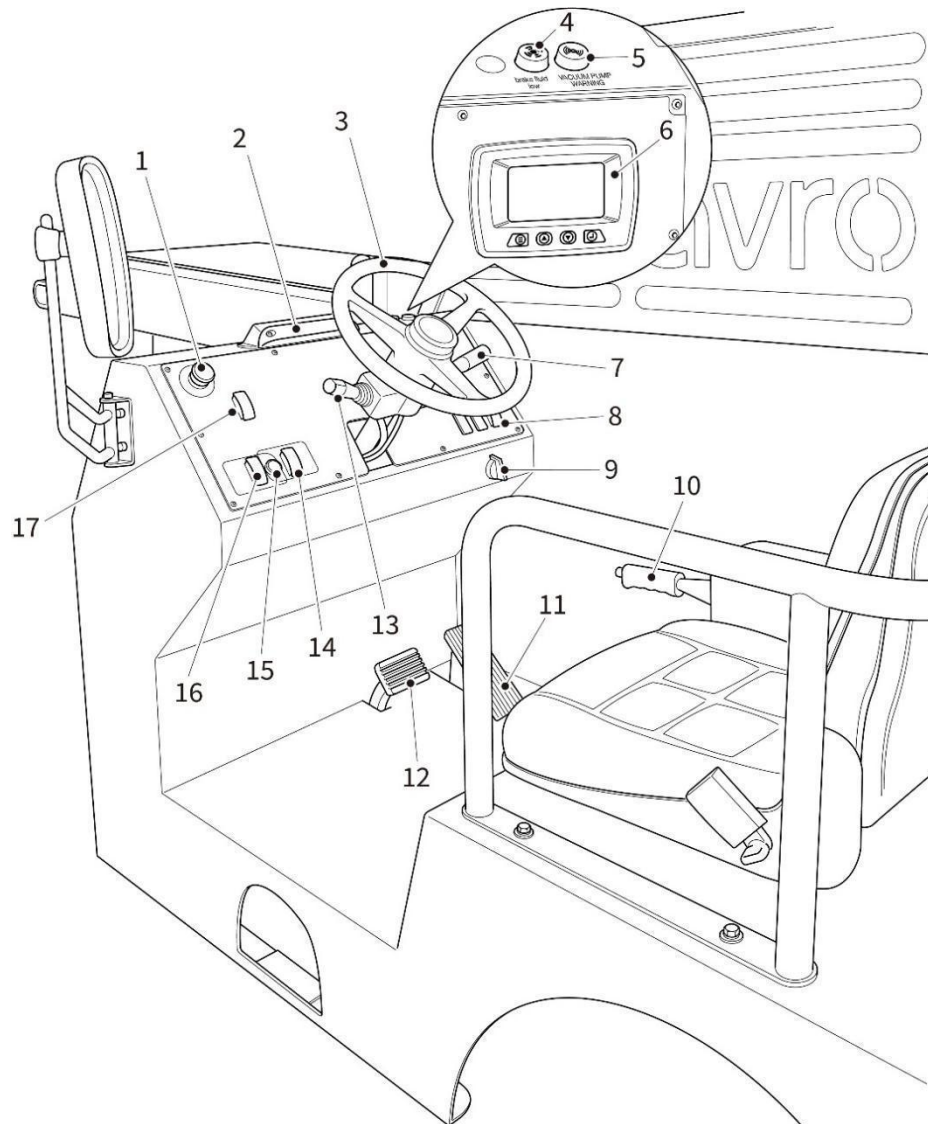

- | | | | |
|---|-----------------------------------|----|--|
| 1 | Emergency Stop switch | 10 | Parking Brake lever |
| 2 | Dashboard Light | 11 | Accelerator Pedal |
| 3 | Steering wheel | 12 | Brake Pedal |
| 4 | Brake Fluid Low lamp | 13 | Turn Signal/Headlamp control |
| 5 | Vacuum Pump Warning lamp | 14 | Rear Lift Cylinder Raise/Lower switch |
| 6 | Dash Display Screen | 15 | Lift Cylinder Interlock switch |
| 7 | Forward/Reverse direction control | 16 | Front Lift Cylinder Raise/Lower switch |
| 8 | Front working light switch | 17 | Drivers Throttle Select switch |
| 9 | Start/Ignition switch | | |

Figure 5 – Driver's Compartment controls

The function of the Driver's Compartment controls and indicators is described in the following Table:

Number	Description	Function
1	Emergency Stop switch	Pressing this switch shuts down the vehicle.
2	Dashboard light	When the vehicle lights are switched ON, the dashboard light is also switched ON, illuminating the Dashboard.
3	Steering wheel	Controls vehicle steering.
4	Brake Fluid Low warning lamp	Illuminates when the Brake Fluid level is low. Replenish the Brake Fluid immediately.
5	Vacuum Pump Warning lamp	Power assisted brakes are not fully functional: - the vacuum level is insufficient. Report the FAULT, and do not use the vehicle until the Brake System has been repaired.
6	Dash Display Screen	Displays speed, fault information, operating time, and important warning information.
7	Forward/Reverse direction control	Used to select forward or reverse direction.
8	Front working light switch	Used to switch the front working light ON/OFF. The front working light is fitted to the underside of the front part of the Belt Frame Assembly.
9	Ignition switch	2-position ON-OFF rotary switch used to Start-Up and Switch Off the Belt Loader.
10	Parking Brake Lever	Used to apply, or release, the Parking Brake.
11	Accelerator pedal	Controls drive speed.
12	Brake pedal	Applies Service Brake.
13	Lights control	Controls headlamps, and Left/Right turn indicator lights
14	Rear Lift Cylinder Raise/Lower switch	Used to raise and lower the rear of the Belt Frame Assembly
15	Lift Cylinder Interlock switch	This switch is a safety feature to prevent inadvertent raising or lowering of the Belt frame Assembly. The Front Lift Cylinder Raise/Lower switch and the Rear Lift Cylinder Raise/Lower switch WILL NOT OPERATE until the Lift Cylinder Interlock switch has been pressed, and must be held down during operation
16	Front Lift Cylinder Raise/Lower switch	Used to raise and lower the front of the Belt Frame Assembly
17	Drivers Throttle selector switch	A two position rocker switch that is used to select either vehicle driving or operation of the conveyor belt. It is NOT possible to drive the vehicle and operate the belt at the same time.

STEERING COLUMN COMBINATION SWITCH CONTROLS

Refer to Figure 6. The left side of the steering column combination switch is the Turn Signal/Headlamp control combination switch. The right side is the Forward/Reverse Gear Switch.

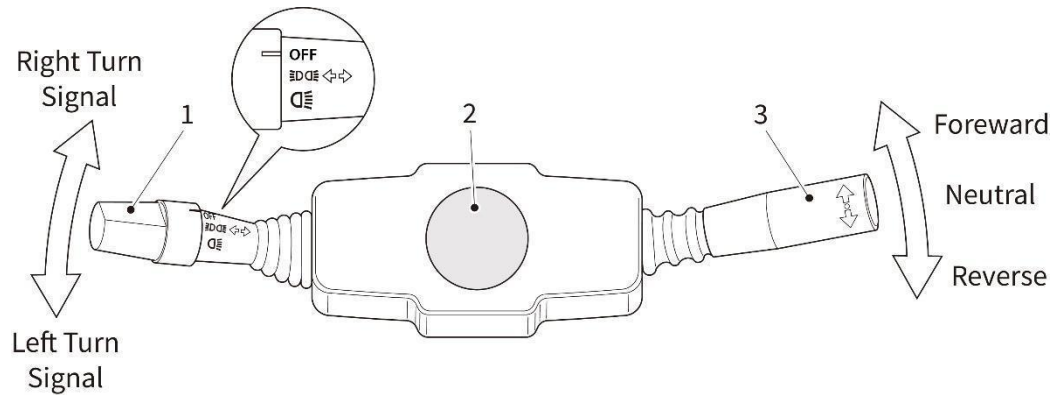

- | | | | |
|---|------------------------------|---|-----------------------------|
| 1 | Turn Signal/Headlamp control | 3 | Forward/Reverse Gear Switch |
| 2 | Steering Column | | |

Figure 6 – Steering Column Combination Switch controls

The Forward/Reverse Gear Switch (3) is a three-position switch:



- The centre position is the Neutral gear position. The Gear Shift MUST be in the N position when the vehicle is started.
- The Up position selects forward driving. Note that the Foot Brake must be pressed to select gear. To move the vehicle forwards, press the Foot Brake, set the Forward/Reverse Gear Switch to the Up position, and press the Accelerator Pedal. The transmission will select the appropriate forward gear automatically. Slowly release the Foot Brake when ready.
- The Down position selects reverse. Note that the Foot Brake must be pressed to select gear. To reverse the vehicle, press the Foot Brake, set the Forward/Reverse Gear Switch to the Down position, and press the Accelerator Pedal. The transmission will select the appropriate reverse gear automatically. Slowly release the Foot Brake when ready.

The Turn Signal/Headlamp control (1) has six settings, three for turn signals and three for controlling the lights. Turn signals are selected by moving the control Up or Down:

- Set the Turn Signal/Headlamp control to the Up position for a right turn signal.
- Set the Turn Signal/Headlamp control to the Down position for a left turn signal.
- The turn indicator lights are Off when the Turn Signal/Headlamp control is in the centre position.

The lights are controlled by rotating the end of the Turn Signal/Headlamp control, as follows. The selected position of the control is indicated by the raised pointer:

- OFF position. All lights are Off. Only used when the vehicle is parked.

-  Position. The front position lights and the dash button indicator lights all illuminate.
- In addition, the brake lights will illuminate when the Brake Pedal is pressed sufficient to engage the service brake, and the turn indicator lights operate.
-  Position. This setting functions the same as the  position, and in addition, the headlights are On.

DRIVER'S COMPARTMENT BELT FRAME CONTROLS

Refer to Figure 7 below.

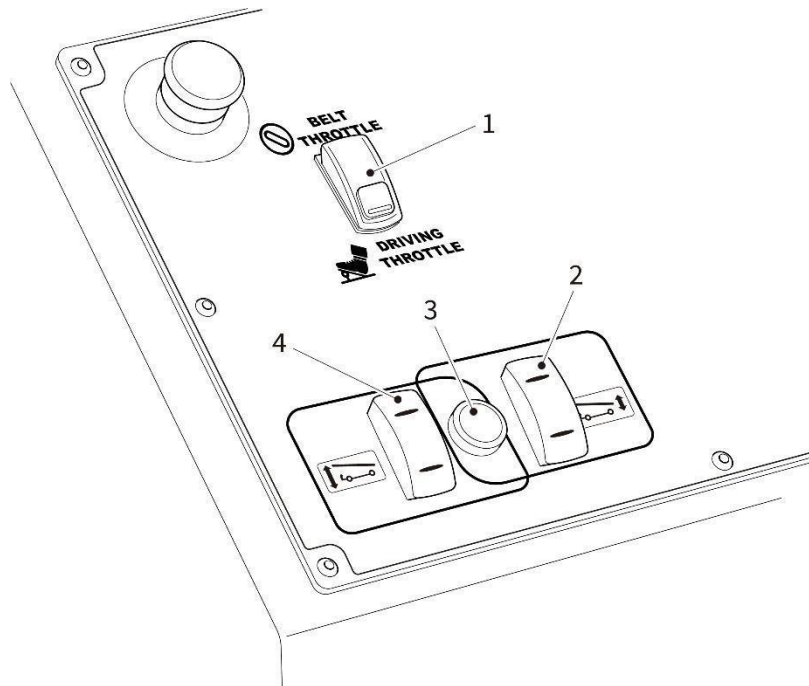

- | | | | |
|---|---------------------------------------|---|--|
| 1 | Drivers Throttle Select switch | 3 | Lift Cylinder Interlock switch |
| 2 | Rear Lift Cylinder Raise/Lower switch | 4 | Front Lift Cylinder Raise/Lower switch |

Figure 7 – Drivers' Compartment Belt Frame controls

The Drivers Throttle Select switch is a two-position rocker switch that is used to select either vehicle driving or operation of the conveyor belt.

- Press down on the top of this switch to activate the Belt Throttle, which allows the conveyor belt to operate, and the speed of the belt to be varied using the Belt Speed Control knob.
- Press down on the lower part of this switch to activate the Driving Throttle, which allows the vehicle to move.

Interlocks make sure that it is NOT possible to drive the vehicle and operate the conveyor belt at the same time.

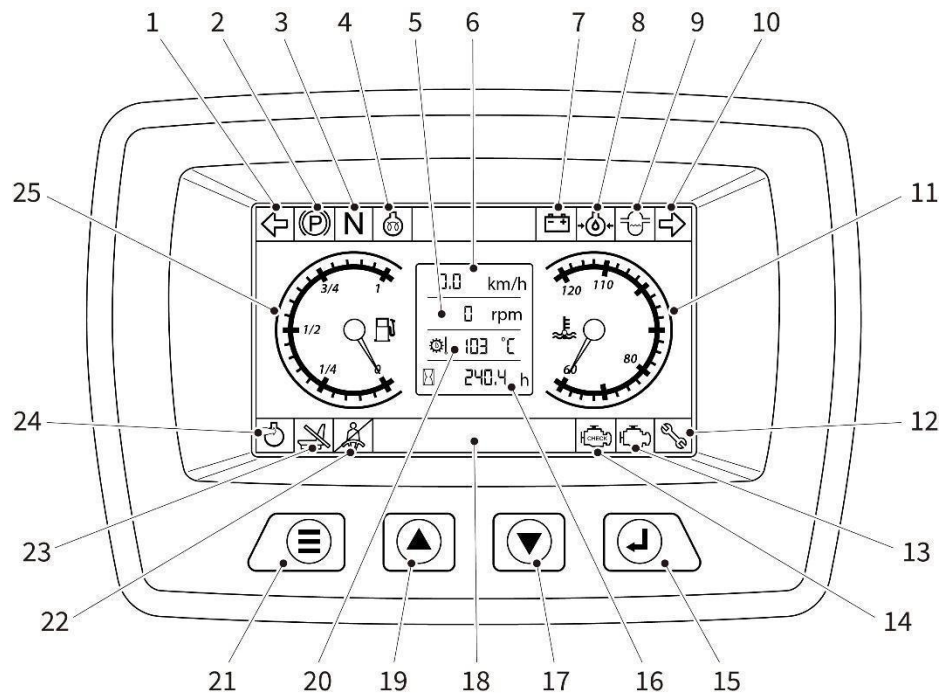

- | | | | |
|----|--|----|--|
| 1 | Left turn signal | 14 | Engine malfunction indicator |
| 2 | Park brake indicator | 15 | Enter/Return button |
| 3 | Neutral (gear) position indicator | 16 | Chronograph (operational hours meter) |
| 4 | Preheat indicator | 17 | Menu/Page down button |
| 5 | Engine tachometer (in rpm) | 18 | Fault code and alarm display area |
| 6 | Speedometer (in kph) | 19 | Menu/Page up button |
| 7 | Charging indicator | 20 | Oil temperature (Transmission) |
| 8 | Engine oil pressure low warning | 21 | Menu button |
| 9 | Coolant level indicator | 22 | Seatbelt engaged indicator |
| 10 | Right turn signal | 23 | Operator present indicator |
| 11 | Coolant temperature gauge | 24 | Transmission oil temperature indicator |
| 12 | Service (maintenance required) indicator | 25 | Fuel gauge |
| 13 | MIL fault indicator | | |

Figure 8 – Dash Display Screen (Instrument Panel)

The BL30D control system includes a series of settings that are pre-set at the factory. These factory settings optimise the performance and safety of the vehicle. DO NOT attempt to alter the factory settings.

The menu button (17) allows access to a series of menus that are used to set-up the Belt Loader. If the menu button is pressed, or accidentally tripped, further progress is blocked by a password. DO NOT attempt to proceed further. These factory settings must not be altered. Press the Menu Item Select button (14) to exit the menus.

LETHAL DANGER – DO NOT ALTER FACTORY SETTINGS



DO NOT attempt to alter the factory settings. Lethal injury may result. The factory settings optimise the safety of the Belt Loader.

Altering the factory settings invalidates the Warranty on the Belt Loader.

On the Dash Display Screen, the Fault Code Display area (16) is normally “Running Well”. In the event of a fault or malfunction on the Belt Loader it will sometimes (but not always) display a fault code that can be used to identify the problem. Illumination of the MIL Fault indicator (11) also indicates a fault on the Belt Loader.

PARKING BRAKE

To engage the Parking Brake, press the button on the Parking Brake Lever and pull-up the Parking Brake Lever as far as it will go. To disengage the Parking Brake, press the button on the Parking Brake Lever and lower the Parking Brake Lever as far as it will go.

BELT SPEED CONTROL KNOB

The speed of the conveyor belt may be adjusted using the Belt Speed Control Knob (Fig 9) located on the steps at the rear of the BL30D Belt Loader.

- Turn the control knob clockwise to accelerate the belt.
- Turn the control knob counter-clockwise to decelerate the belt.
- The control knob **MUST** be returned to minimum speed position after every loading/unloading operation.

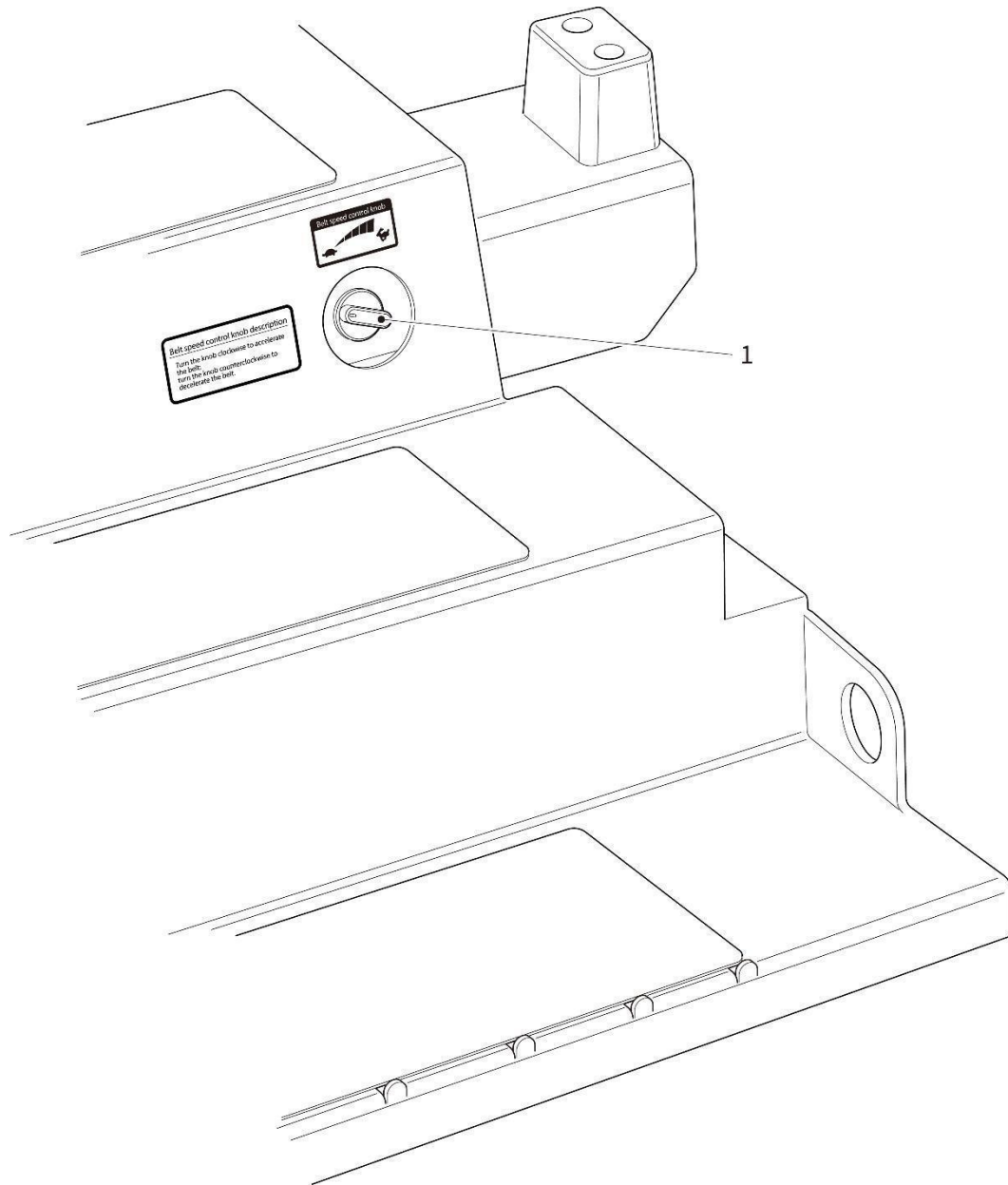

- 1 Belt Speed Control Knob

Figure 9 – Belt Speed Control Knob

Two Belt Control Boxes are fitted to the left-hand side of the Belt Frame, one at the front of the Belt Frame and one at the rear. The function of the Belt Control Boxes is to allow the operator to incrementally move the BL30D vehicle forwards or backwards in small movements, until the optimum position for loading baggage onto the aircraft is reached.

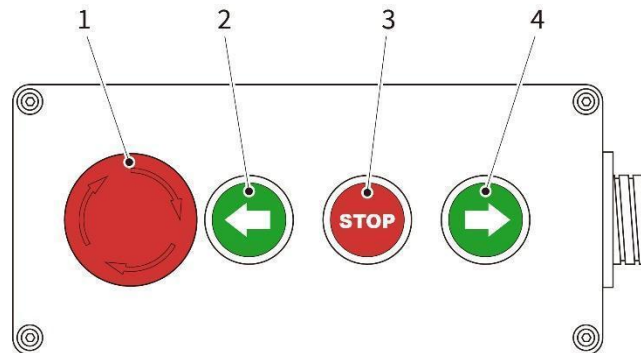

- | | | | |
|---|---------------------------------------|---|---------------------------------------|
| 1 | EMERGENCY STOP switch | 3 | Conveyor belt STOP button |
| 2 | Conveyor belt forward movement button | 4 | Conveyor belt reverse movement button |

Figure 10 – Belt Control Box

The function of the Belt Control Box switches is as follows:

- Pressing the conveyor belt forward movement button (2) starts the conveyor belt moving, in a forward direction, carrying baggage towards the front of the Belt Frame Assembly.
- Pressing the conveyor belt reverse movement button (4) starts the conveyor belt moving, in the reverse direction, carrying baggage towards the rear of the Belt Frame Assembly.
- To halt the conveyor belt, press the conveyor belt STOP button (3).
- Pressing the EMERGENCY STOP switch (1) switches OFF the whole vehicle.

When changing the direction of movement of the conveyor belt, between forward and reverse, press the conveyor belt STOP button first.

The Belt Frame Assembly includes a luggage rail to the left of the Belt to prevent luggage and cargo falling off the side of the Belt.

SAFETY INTERLOCKS

The BL30D is equipped with the safety interlocks described in the following Table.

No.	Interlock	Function
1.	Start-Neutral interlock	The engine can only be started-up when the gear shift is in the Neutral position.
2.	Transmission - conveyor belt interlock	An interlock between the Transmission and the Belt Frame Assembly conveyor belt. The conveyor belt can only be operated when the vehicle is stationary. When the conveyor belt is running the Transmission will not engage into forward or reverse gear.
3.	Emergency Shutdown.	An EMERGENCY STOP button is provided at each end of the Belt Frame Assembly. An EMERGENCY STOP button is also provided in the driver's compartment. Pressing any one of the EMERGENCY STOP buttons will shut the vehicle down completely.
4.	Parking Brake - Conveyor Belt interlock	The conveyor belt can only operate when the Parking Brake is engaged.
5.	Conveyor belt operation – Belt Frame Assembly raise/lower interlock	The conveyor belt, and the Belt Frame Assembly raise/lower hydraulic cylinders. Both cannot be operated at the same time.
6.	Rear Hand throttle - Transmission interlock	The rear hand throttle must be reset before the vehicle can be put into gear.
7.	Parking Brake - Transmission interlock	When the gear switch is in the driving position, if the Parking Brake is not disengaged, the gear shift will not work and the audible alarm will sound.
8.	Reverse Gear - Alarm interlock	An audible alarm sounds when the vehicle is in reverse gear.

In addition, the Belt Frame Assembly can only be raised or lowered from the cab. All exposed controls are rainproof.

OIL RETURN FILTER GAUGE

The Oil Return Filter, which is located on top of the Hydraulic Oil Tank, includes an oil pressure gauge (Figure 11).

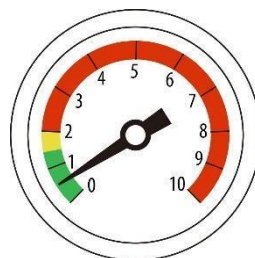

Figure 11 - Pressure gauge on Oil Return Filter

The function of this pressure gauge is to indicate the condition of the filter element located inside the Oil Return Filter. It does this by measuring the difference in oil pressure across the filter element to determine whether the filter element is blocked. This pressure gauge **MUST** be checked at the start of every shift **BEFORE** using the vehicle. Regular checking of this pressure gauge is also included in the Scheduled Maintenance for the BL30D vehicle.

- If the needle of the pressure gauge is pointing to the green segments, the filter element is serviceable.
- If the needle of the pressure gauge is pointing to the yellow segment, there is a constriction in the filter element. DO NOT operate the vehicle until the filter element has been cleaned or replaced, as applicable.
- If the needle of the pressure gauge is pointing to any of the red segments, the filter element is blocked. DO NOT operate the vehicle until the filter element has been cleaned or replaced, as applicable.

START-UP

Before starting the BL30D Belt Loader:

- Make sure that all the EMERGENCY STOP switches are in the open position.
- Put the Forward/Reverse Gear Switch into the centre, Neutral, position.
- Rotate the Start Switch in a clockwise direction to the On position. This turns on the electrical power to the vehicle. The instrument panel will activate, and the Belt Loader will self-test for approximately 3 to 4 seconds.
- If the self-test detects a fault, do not attempt to use the Belt Loader and REPORT the fault.
- When the self-test is completed successfully, the Instrument Panel will display vehicle data normally.
- Turn start switch to crank position, engine will start.
- If the engine fails to start, wait at least 10 seconds then repeat the steps above.
- Step on the Brake Pedal, release the Parking Brake, and the Parking Brake indicator on the Instrument Panel will extinguish.
- Check that it is safe to move the Belt Loader.
- Push the Forward/Reverse Gear Switch upwards to the Forward position to engage the forward gears.

NOTE

If the Belt Loader fails to start after several attempts, REPORT the problem. Have a suitably trained and authorised vehicle mechanic check the fuel and ignition system for faults and perform the Troubleshooting Procedure given in this manual.

- Allow the engine to idle for a few seconds before proceeding to the next step.

WARNING – DAMAGE TO HYDRAULIC SYSTEM



Before using the vehicle, at the start of every shift, check the Oil Return Filter pressure gauge. Make sure that the pressure gauge needle is in the green area. If the needle is NOT in the green area DO NOT use the vehicle, SWITCH OFF the vehicle, and report the problem. The filter element located inside the Oil Return Filter, MUST be removed, cleaned, and re-fitted BEFORE using the vehicle.

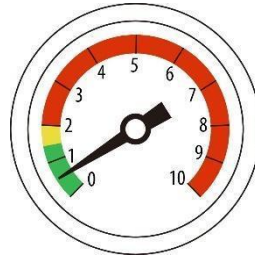

Figure 12 - Pressure gauge on Oil Return Filter

- Check the Oil Return Filter pressure gauge located on top of the Hydraulic Oil Tank (Figure 12). Make sure that the pressure gauge needle is in the green area. If the needle is NOT in the green area DO NOT use the vehicle, SWITCH OFF the vehicle, and REPORT the problem. Have a suitably trained and authorised vehicle mechanic remove and clean the filter element located inside the Oil Return Filter, BEFORE using the vehicle.
- Rotating the end of the Turn Signal/Headlamp control to select and switch On the required vehicle lights.
- Slowly release the Brake Pedal. Note that with the engine idling, Forward gear selected, and the Brake Pedal released the vehicle will move slowly forward at a speed that should not exceed 2.5 mph (4 km/hr).
- Press the Accelerator Pedal. The vehicle will move forward at the normal travel speed as selected by pressing the Accelerator Pedal.
- If the vehicle does not move forward, check that the Parking Brake has been released. If it has, rotate the Start Switch in a counter-clockwise direction to the Off position, put the Forward/Reverse Gear Switch into the Neutral position, and engage the Parking Brake. Check that the Brake Pedal is not depressed or jammed in the depressed position. Remove any debris or objects that may restrict the operation of the Brake Pedal. Then repeat this start-up procedure. If the vehicle still does not move forward, rotate the Start Switch to the Off position, put the Forward/Reverse Gear Switch into the Neutral position, engage the Parking Brake, and REPORT the problem.
- Test the Foot Brake and the Parking Brake before using the Belt Loader. The brakes MUST have a good and reliable performance. If not, do not use the Belt Loader and REPORT the problem.
- Make sure that the Belt Frame Assembly is in the fully lowered position. If necessary, use the Belt Frame Controls to lower the Belt Frame Assembly.
- Park the vehicle on a flat surface.
- Check the hydraulic oil level by viewing the Fluid Level Gauge through the observation port on the right side of the vehicle. The oil level should be at the highest red mark, between the degree line and the lowest red tick mark. If necessary, top-up the oil level in the hydraulic oil tank with clean, new, hydraulic oil through the oil port of the Oil Return Filter Assembly until the Fluid Level Gauge indicates that the hydraulic oil tank is full.
- DO NOT select Neutral gear, or switch OFF the engine, when going downhill.

PARKING

When parking the Belt Loader:

- Make sure that the Belt Loader is stable on level ground.
- Set the Forward/Reverse Gear Switch to the Neutral position.
- Engage the Parking Brake.
- Rotate the end of the Turn Signal/Headlamp control to switch OFF the vehicle lights.
- Rotate the Start Switch counter-clockwise to the OFF position.

OPERATION

Perform baggage loading operations as follows:

- Drive to a suitable baggage loading position close to the aircraft, step on the Brake Pedal to stop the vehicle, engage the Parking Brake, and set the Forward/Reverse Gear Switch to Neutral.

NOTE

Raising and lowering the Belt Frame Assembly, and operation of the conveyor belt is only possible when the Parking Brake is engaged.

FATAL WARNING – CRUSH INJURY



It is strictly forbidden to stand or sit under the Belt Frame Assembly when it is in the raised position. Do not place hands, arms, legs, or feet under the Belt Frame Assembly when it is in the raised position. A hydraulic failure, or unintended movement of the Belt Frame Assembly, can cause serious or fatal injury.

- At night, or during poor visibility, switch ON the front working light.
- Using the Belt Frame controls in the Driver's compartment, adjust the height of the of the Belt Frame Assembly so that the front of the conveyor belt is at the same height as the aircraft door.

WARNING – DAMAGE TO AIRCRAFT



DO NOT step on the Accelerator Pedal when approaching the aircraft.

When approaching the aircraft, make sure that the vehicle is only moving forward at idling speed. Keep your foot on the Brake Pedal while manoeuvring close to an aircraft. When close to an aircraft, if in doubt, apply the Foot Brake.

- With the Forward/Reverse Gear Switch set to Forward and the engine idling, step on the Brake Pedal. Release the Parking Brake, and slowly lift your foot to release the Brake Pedal. The Baggage Loader will slowly move forward at a speed of 2.5 mph (4 km/hr). Drive the Baggage Loader close to the aircraft door.
- Step on the Brake Pedal to stop the vehicle, engage the Parking Brake, and set the Forward/Reverse Gear Switch to Neutral.

WARNING – USE HANDRAIL



Before stepping on to the Belt Frame Assembly, or loading/unloading baggage, raise the Handrail to its operating position. Make sure that the Handrail is secured in the raised position by moving the handrail securing pin from its stowage location to the engaged position, as shown in Fig 13.

When the baggage loading/unloading operation is complete, return the handrail securing pin to its stowage location. Then lower the Handrail to its stowed position before moving the vehicle.

- On the Belt Frame Assembly, raise the Handrail to its operating position. Refer to Figure 13 below. Remove the handrail securing pin from its stowage location. Then lock the Handrail in the raised position by fitting the handrail securing pin into its engaged position in the rear bracket of the Handrail. Make sure that the handrail securing pin goes through the holes in BOTH sides of the bracket.

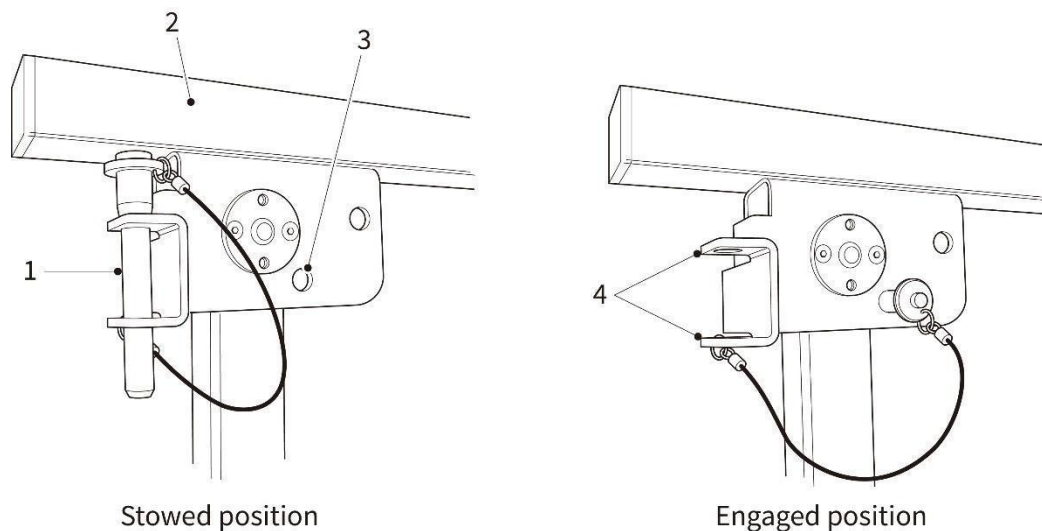

- | | | | |
|---|-----------------------|---|-----------------------|
| 1 | Handrail securing pin | 3 | Engaged position hole |
| 2 | Handrail | 4 | Stowage location |

Figure 13 – Handrail securing pin

- The handrail securing pin is attached to its stowage location by a lanyard. However, if the handrail securing pin is lost or damaged it **MUST** be replaced with a new handrail securing pin. **DO NOT** use an incorrect substitute item as that may cause the Handrail to collapse when in use.
- On the Belt Frame Assembly, raise the luggage rail to the left of the conveyor belt to prevent luggage and cargo falling off the side of the conveyor belt.

WARNING – CONVEYOR BELT



DO NOT step onto the conveyor belt while the conveyor belt is moving.

DO NOT start the conveyor belt when someone is on the conveyor belt.

The conveyor belt has pinch points. Keep hands and clothing away from potential pinch points. Wear suitable protective gloves.



When in the vicinity of a moving conveyor belt, make sure that loose clothing, straps and belts, long hair, neckties, lanyards, necklaces, scarfs, bracelets, and wrist straps, etc., are all secured tight or removed. If any of these items are caught by the conveyor belt it can drag the person into the mechanism.

- On the Belt Control Boxes, use either the conveyor belt forward movement button, or the conveyor belt reverse movement button, as applicable, to start the conveyor belt.
- The movement of the conveyor belt may be stopped at any time by pressing the conveyor belt STOP button.
- The speed of the conveyor belt may be adjusted using the Belt Speed Control Knob located on the steps above the left rear wheel. Turn the knob clockwise to accelerate the conveyor belt. Turn the knob counter-clockwise to decelerate the conveyor belt.
- In the event of an emergency or problem while loading or unloading baggage or cargo, press the EMERGENCY STOP button on either of the Belt Control Boxes. Or press the EMERGENCY STOP button in the Driver's compartment.
- When the loading or unloading operation is complete, stop the movement of the conveyor belt by pressing the conveyor belt STOP button. On the Belt Frame Assembly, lower the luggage flap to the left of the conveyor belt to its stowed position.
- On the Belt Frame Assembly, remove the handrail securing pin from its engaged position and place the pin in its stowage location. Then lower the Handrail to its stowed position.
- With the Forward/Reverse Gear Switch set to Neutral and the engine idling, step on the Brake Pedal. CHECK THAT THE AREA AROUND THE VEHICLE IS CLEAR. Set the Forward/Reverse Gear Switch to Reverse, release the Parking Brake, and slowly lift your foot to release the Brake Pedal. Gently press on the Accelerator Pedal and slowly reverse away from the aircraft.
- Once clear of the aircraft, drive the vehicle normally to its next destination.

WORKING UNDER THE BELT FRAME ASSEMBLY

When it is necessary to perform maintenance or servicing beneath a Belt Frame Assembly that is in the raised position, it is **ESSENTIAL** that Belt Frame Assembly is locked in the raised position with the Safety Prop and the Belt Frame Locking Pin. This is to prevent the Belt Frame Assembly dropping on the person performing the maintenance or servicing, for example, because of a hydraulic fault. Locking the Belt Frame Assembly in the raised position with both the Safety Prop and the Belt Frame Locking Pin provides two levels of safety against that hazard.

FATAL WARNING – CRUSH INJURY



Before performing maintenance or servicing beneath the Belt Frame Assembly when it is in the raised position, lock the Belt Frame Assembly in the raised position with the Safety Prop and the Belt Frame Locking Pin. A hydraulic failure, or unintended movement of the Belt Frame Assembly, can cause serious or fatal injury.

Lock the Belt Frame Assembly in the raised position as follows:

- Refer to Figure 14. Raise the Front Lifting Cylinder until the main rollers pass the safety locking position (4).

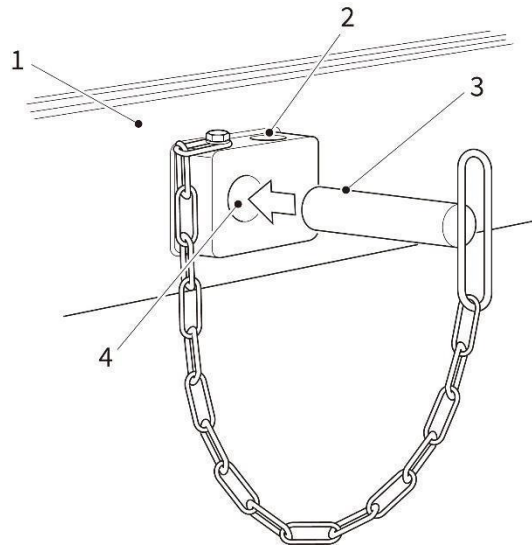

- | | | | |
|---|---------------------|---|-------------------------|
| 1 | Belt Frame Assembly | 3 | Belt Frame Locking Pin |
| 2 | Stowage position | 4 | Safety locking position |

Figure 14 - Belt Frame Locking Pin

- Refer to Figure 15. Remove the Safety Prop locking pin (3) from its stowage position.
- Taking care not to go underneath the raised Belt Frame Assembly, raise the Safety Prop (1) so that it engages with the Front Lifting Frame as shown in Figure 15.
- Fit the Safety Prop locking pin (3) to its lock position. This will secure the Belt Frame Assembly in the raised position.

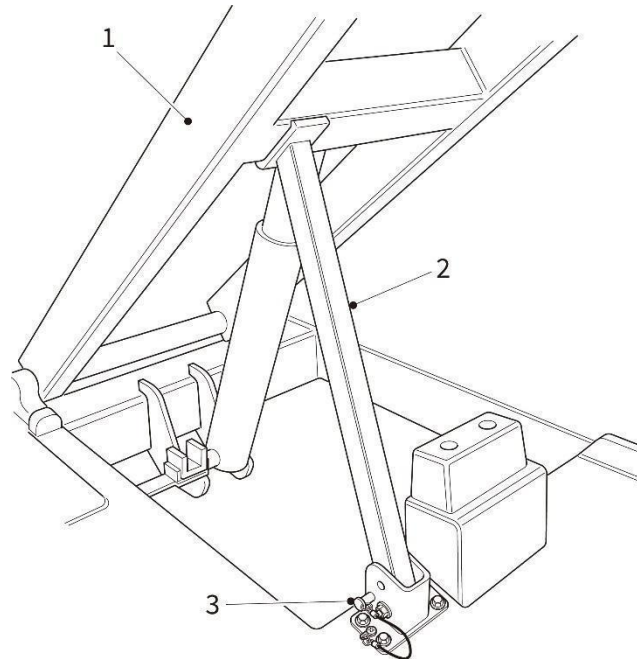

- | | | | |
|---|---------------------|---|-------------|
| 1 | Front Lifting Frame | 3 | Locking Pin |
| 2 | Safety Prop | | |

Figure 15 – Safety Prop

- Refer to Figure 14. Remove the Belt Frame Locking Pin (3) from its stowage position (2).
- Insert the Belt Frame Locking Pin into its safety locking position (4), but do not push it fully home. Lower the Front Lifting Cylinder until the main roller engages with the Belt Frame Locking Pin. Then push the Belt Frame Locking Pin fully home. This will also secure the Belt Frame Assembly (1) in the raised position.

When the maintenance or servicing activity is finished:

- Refer to Figure 15. Taking care not to go underneath the raised Belt Frame Assembly, remove the Locking Pin (3) from its lock position and lower the Safety Prop (2) to its stowage position. It may be necessary to slightly raise the Front Lifting Cylinder to release the Safety prop from the Front Lifting Frame.
- Fit the Locking Pin into its stowage position.
- Raise the Front Lifting Cylinder, return the Belt Frame Locking Pin (3) to its stowage position (2), and then completely lower the Belt Frame Assembly.

FUNCTIONAL DESCRIPTION OF MAIN ASSEMBLIES

STRUCTURE

The BL30D Belt Loader is comprised of the following main assemblies:

- Chassis and vehicle body.
- Engine.

- Transmission.
- Drive Shaft.
- Drive Axle.
- Brake system
- Front Axle.
- Steering system.
- Belt Frame Assembly.
- Front and rear Lifting Frames.
- Two hydraulic Lifting Cylinders.
- The hydraulic system.
- The electrical system.

Note that there is no suspension system on the BL30D Belt Loader.

ENGINE

The engine is a Cummins QSF2.8 diesel engine. It is a 4-stroke, in-line cylinders Diesel engine.. For the description and technical details of the engine, refer to the “KDI 1903TCR - KDI 2504TCR owner Manual” appended to this BL30D manual.

AUTOMATIC TRANSMISSION

The BL30D is fitted with an Okamura, Model Y43280D, Automatic Transmission. It has a 3-element, 1-stage, 2-phase, torque converter. Forward and reverse gears are automatic. For the description and technical details of the Automatic Transmission, refer to the Okamura Transmission Service Manual, No. TSM11-003, for the Model Y43280D, which is appended to this BL30D manual.

CARDAN PROPELLER SHAFT (DRIVE SHAFT)

The Drive Shaft is a stiff propeller shaft, with universal joints at the front and rear that attach the Drive Shaft to the Automatic Transmission and Drive Axle.

DRIVE AXLE

The Drive Axle is the rear axle, and is comprised of the differential, drive unit, wheel hubs, axle tube, rear brakes, and rear wheels.

BRAKE SYSTEM

There are two braking systems on the BL30D, a Foot Brake System (Service Brake) , and a Parking Brake (Hand Brake).

The Foot Brake System is a four-wheel braking system that includes a vacuum valve. When the Foot Brake is applied, brake fluid from the brake fluid reservoir is applied to all four brakes. The system is reliable and easy to use.

To apply the Parking Brake, simply pull the Parking Brake Lever upwards. The hand brake cable attached to the Parking Brake Lever will apply the pull force to the Brake Assemblies fitted to the rear (drive) axle, thus engaging the park brake.

FRONT AXLE AND STEERING SYSTEM

The Front Axle is the steering axle. The BL30D is fitted with a power steering system that forms part of the vehicle hydraulic system. When the steering wheel is turned, a hydraulic steering unit, located below the driver's dash, applies hydraulic oil from the hydraulic system to the steering cylinder attached to the Front axle. In response the steering cylinder turns the Front Axle, causing the vehicle to turn.

CHASSIS AND VEHICLE BODY

The vehicle body and chassis are constructed from welded steel plate. The driver's compartment is also constructed from welded steel plate and is bolted to the chassis and vehicle body. The vehicle has a low centre of gravity giving the vehicle good stability. The driver's compartment has space for the driver only, and provides the driver with a wide field of view. The position of the driver's seat can be adjusted backwards and forwards.

A single towing lug (hitch) is located on the front of the BL30D. A second towing lug (hitch) is located on the bottom step at the rear of the BL30D. These towing lugs are NOT designed to be used for towing other vehicles, trailers, baggage carts, cargo dollies, etc., and MUST NOT be used for that purpose. The sole purpose of the towing lugs is to provide attachment points for towing chains/cables when recovering a broken down BL30D.

BELT FRAME ASSEMBLY

The function of the Belt Frame Assembly is to safely transport luggage and cargo to an aircraft's cargo door. To provide the necessary strength and rigidity, the Belt Frame Assembly is constructed around a welded steel Belt Frame made from U-channel steel beams. The movement of the luggage is performed by a rubber conveyor belt. To provide safe access for baggage handlers to the aircraft hold, a collapsible Handrail Assembly is provided on the right-hand side of the Belt Frame Assembly. The Handrail Assembly MUST be raised to its' operating position, and locked in that position, BEFORE anyone sets foot on the conveyor belt. The Handrail Assembly also prevents luggage falling off the right-hand side of the conveyor belt. Front and rear luggage flaps, located on the left-hand side of the conveyor belt, prevent luggage from falling off that side.

Control and EMERGENCY STOP switches are located at the front and rear of the Belt Frame Assembly.

A hydraulic motor located at the rear of the Belt Frame Assembly drives the conveyor belt, via a rear drive drum. Hydraulic power for the motor is provided by the vehicle hydraulic system. A front belt drum at the front of the Belt Frame Assembly, acts as a return roller for the conveyor belt. The conveyor belt is supported by five short stainless steel idler rollers, 27 long stainless steel idler rollers, and four stainless steel support plates. Two Guide Wheel Assemblies keep the conveyor belt running straight. A Front Roller Adjustment Assembly and a Tightening Support Assembly maintain the correct tension in the conveyor belt.

Two proximity sensors are mounted on the front underside of the Belt Frame Assembly to warn the driver when the Belt Frame Assembly is close to an aircraft. There is also a protective bumper fitted to the front edge of the Belt Frame Assembly.

FRONT AND REAR LIFTING FRAMES AND LIFT CYLINDERS

Both the front and rear Lifting Frames are welded steel structures. The front and rear Lifting Frames perform two functions:

- The front and rear Lifting Frames are part of the mechanisms that raise and lower, respectively, the front and rear of the Belt Frame Assembly.
- The Lifting Frames support the weight of the Belt Frame Assembly.

Lifting and lowering of the Belt Frame Assembly is performed by the front and rear Hydraulic Lift Cylinders. Both Lift Cylinders are single-acting, piston, hydraulic cylinders, with hydraulic power applied to the full-bore side of the hydraulic cylinder. The full-bore side of each Lifting Cylinder is attached to the chassis of the vehicle, and the piston (rod) of each Lifting Cylinder is attached to the associated Lifting Frame. As hydraulic oil flows into, or out of, the full-bore side of the Lift Cylinder, its piston is forced in or out. The movement of the piston raises or lowers the associated Lifting Frame, thus raising or lowering the respective end of the Belt Frame Assembly. The Lifting Frames and Belt Frame Assembly can be lowered unpowered.

During maintenance and servicing, or following a failure in the hydraulic system, the front and rear Lifting Frames can be raised using a hand pump attached to the hydraulic oil tank.

HYDRAULIC SYSTEM

A hydraulic circuit diagram for the BL30D is provided in the Hydraulic Schematic section of this manual. The hydraulic system comprises:

- A Hydraulic Oil Tank.
- A Gear Pump.
- A suction filter inside the Oil Tank, on the output port to the Gear Pump.
- A cut-off valve, mounted on the outside of the Oil Tank, in the hydraulic line to the Gear Pump.
- An Oil Return Filter Assembly, located on top of the Oil Tank.
- An emergency Hand Pump, located on the side of the Oil Tank.
- A priority valve.
- A Steering Unit.
- A Steering Cylinder (described previously, above).
- An electronically controlled Integrated Hydraulic Valve Assembly.
- The Front Lift Cylinder, the Rear Lift Cylinder (both described previously, above) and the associated solenoid valves.
- The hydraulic motor.

ELECTRICAL SYSTEM

The vehicle electrical system is a 12V DC system. Electrical schematics for the BL30D are provided in the Electrical Schematics section of this manual.

REFUELLING

Refer to Figure 16 and refuel the BL30D Belt Loader as follows:

WARNING – PETROLEUM – FIRE AND HEALTH HAZARD



Fuel expands when heated. Expanding fuel in an over full tank can cause spills and leaks. Do not overfill the fuel tank.

Do not eat, drink or smoke when refuelling the vehicle. If fuel is ingested, or comes into contact with your eyes, nose or mouth, seek medical assistance immediately.

Fuel spillages are a fire and slip hazard. Always clean up any spillages.

- Make sure that the vehicle is shut down, and that there are no open flames or combustibles nearby.
- Make sure that the vehicle is standing on level ground, and that the vehicle is level with the ground.
- Remove and retain the fuel cap.
- Fill the tank with the appropriate grade of diesel.
- Refit the fuel cap.



Figure 16 – Refuelling

STORAGE

If the Belt Loader is not going to be used for a long time:

- Perform monthly, three-month, six-month, and 12-month lubrication.
- Drain the radiator.
- If necessary, perform the cold weather maintenance (“winterize”) described on page 35.
- Remove and clean the battery. Fully charge the battery and store it separately from the vehicle. During storage check the battery once a month: - if the battery voltage has dropped, charge the battery fully.

NOTE

Long term storage of a battery with a reduced charge in it can result in damage to the battery.

- Protect exposed parts against rust, for example, by applying grease.
- Store the Belt Loader under cover.
- Check the engine every month.

RECEIPT AND PREPARATION FOR FIRST USE

On receipt of a new BL30D Belt Loader, before operating the Belt Loader for the first time, you **MUST** perform the following :

- Make sure that all loose packaging has been removed from the Belt Loader.
- Check the Belt Loader and its components for damage. If there is any visible damage, **DO NOT OPERATE THE BELT LOADER**. Contact AvroGSE immediately for assistance. Contact details for AvroGSE are given inside the front cover of this manual.
- Perform an inventory of all parts included with the Belt Loader and verify that all loose components and fasteners are accounted for. If any are missing, contact AvroGSE immediately for assistance.
- Attach all component parts not already attached to the Belt Loader.
- Make sure that all necessary fluids (for example fuel, engine oil, coolant) are checked and additional fluid added as needed.
- Verify that the Belt Loader is fully serviceable by performing the Daily Maintenance checks and Weekly Maintenance checks described in the Scheduled Maintenance section of this manual.
- Move the Belt Loader to its operating location.
- Complete any receipt documentation and maintenance records as required.

After 100 hours of operational use of the Belt Loader, replace the oil in the Transmission. This is in addition to the Transmission oil changes specified in the Scheduled Maintenance and Lubrication Diagram.

MANUAL EMERGENCY OPERATION INSTRUCTIONS

If the motor or hydraulic system fails, the Belt Loader should be removed from the ramp as soon as possible to avoid flight delays. Use the following Emergency Operation Procedures to manually raise the Belt Frame and then manually reset the Belt Frame.

HOW TO MANUALLY RAISE THE BELT FRAME

If the motor or hydraulic system fails, the Belt Frame can be raised using a manually operated Emergency Hydraulic Hand Pump. Raise the front end of the Belt Frame as follows:

- Refer to the Figure below showing the electronic controlled Integrated Hydraulic Valve Assembly.

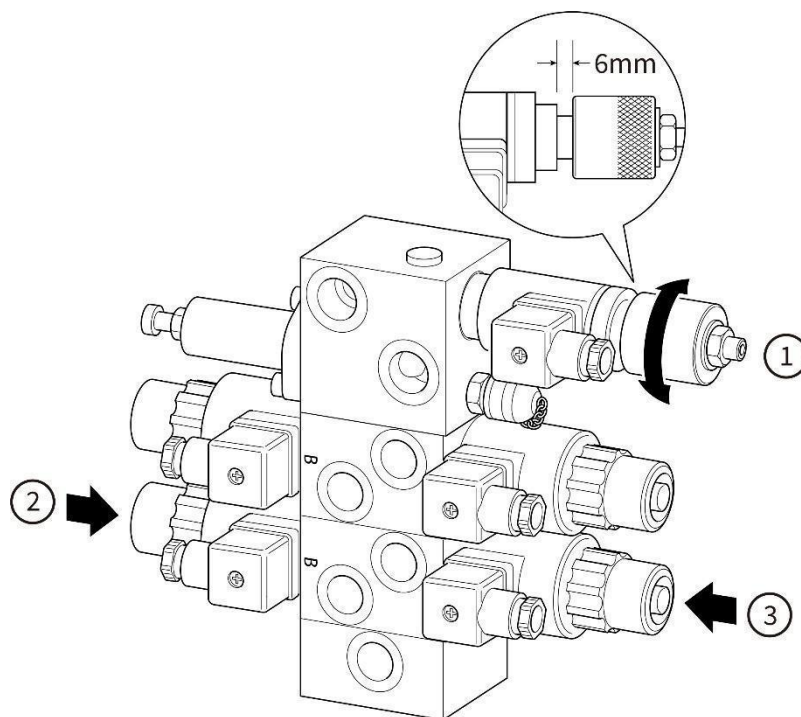

Fig 17 - Integrated Hydraulic Valve Assembly

- When not in use the lever of the Emergency Hydraulic Hand Pump is stowed on top of the hydraulic oil tank. Release the pump lever from the clip that secures it in position on top of the hydraulic oil tank. Then rotate the pump lever counter-clockwise until it is at a right-angle to the vehicle chassis.
- Rotate the pressure increase valve (1) clockwise, by hand, until the valve cannot be rotated any further.
- Then press the solenoid valve manual button (2). The button must be kept in the depressed position.
- Operate the Emergency Hydraulic Hand Pump by moving its lever up and down, as far the lever will travel. A steady pace is recommended. The front end of the Belt Frame will be raised by the action of the pump.
- To halt the raising of the front end of the Belt Frame, stop operating the Emergency Hydraulic Hand Pump lever, and stop pressing the solenoid valve manual button.

Raise the rear end of the Belt Frame as follows:

- Refer to Fig 16. Rotate the pressure increase valve (1) clockwise, by hand, until the valve cannot be rotated any further.
- Press the solenoid valve manual button (3). The button must be kept in the depressed position.
- Operate the Emergency Hydraulic Hand Pump by moving its lever up and down, as far the lever will travel. A steady pace is recommended. The rear end of the Belt Frame will be raised by the action of the pump.
- To halt the raising of the rear end of the Belt Frame, stop operating the Emergency Hydraulic Hand Pump lever, and stop pressing the solenoid valve manual button.

Completion:

- When both the front and rear ends of the Belt Frame have been raised to the desired height, on the hydraulic valve assembly, return the pressure increase valve (1) to its normal position. Rotate the pressure increase valve (1) counter-clockwise, by hand, until the valve cannot be rotated any further. When the valve is fully home, the distance between the rotatable cap and the base of the valve should be approximately 6mm as shown in the illustration.
- When both the front and rear ends of the Belt Frame have been raised to the desired height, return the lever of the Emergency Hydraulic Hand Pump to its stowed position. Make sure that the lever is secured by its retaining clip.
- Lower the Belt Frame as described below.

HOW TO MANUALLY LOWER THE BELT FRAME

Lower the front end of the Belt Frame as follows:

FATAL WARNING – CRUSH INJURY



Make sure that no person or object is near or under the Belt Frame when it is lowered. A crush injury from the Belt Frame will cause serious or fatal injury.

- Before manually lowering the Belt Frame, check that no person or object is near or under the Belt Frame.
- A solenoid valve is located at the bottom of the Belt Frame front hydraulic lift cylinder, as shown in Fig 18. On the solenoid valve, rotate the emergency knob counter-clockwise, by hand, until it cannot be rotated any further.
- The hydraulic lift cylinder will retract once the emergency release knob is rotated counter-clockwise.
- When the front end of the Belt Frame has been lowered, on the hydraulic cylinder solenoid valve, rotate the emergency knob clockwise, by hand, until it cannot be rotated any further.

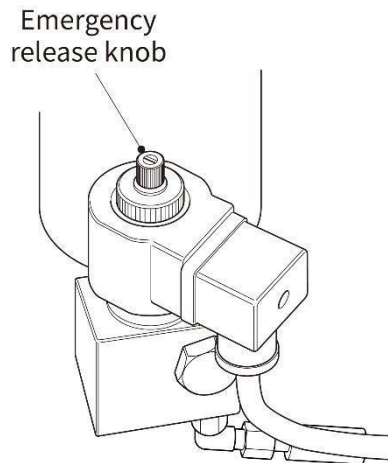

Fig 18 - Belt Frame hydraulic cylinder solenoid valve

Lower the rear end of the Belt Frame:

FATAL WARNING – CRUSH INJURY



Make sure that no person or object is near or under the Belt Frame when it is lowered. A crush injury from the Belt Frame will cause serious or fatal injury.

- A solenoid valve is located at the bottom of the Belt Frame rear hydraulic lift cylinder, as shown in Fig 18. On the hydraulic cylinder solenoid valve, rotate the emergency knob counter-clockwise, by hand, until it cannot be rotated any further.
- When the rear end of the Belt Frame has been lowered, on the hydraulic cylinder solenoid valve, rotate the emergency knob clockwise, by hand, until it cannot be rotated any further.

The Emergency Operation Procedures are now complete. The BL30D Belt Loader can now be towed away.

TOWING INSTRUCTIONS

When towing the BL30D:

- Put the transmission into Neutral and release the parking brake.
- The towing speed must not exceed 6 mph (10km/hr) and the towing distance must not exceed 12 miles (20 km).
- If the towing distance is going to be greater than 12 miles (20 km), or the towing speed is going to be greater than exceed 6 mph (10km/hr), then the rear wheels should be raised off the ground before the BL30D is towed. Failure to raise the rear wheels off the ground in these circumstances may result in damage to the BL30D.
- There must be a person sitting in the cab to steer the BL30D during towing; unless the rear wheels have been raised off the ground.

SCHEDULED MAINTENANCE

Scheduled maintenance is limited to the activities specified in the Scheduled Maintenance Table below. The maintenance intervals given are approximate, assume heavy use of the BL30D Belt Loader, and may be varied by ±10% without adverse effects. Every Belt Loader should be inspected and serviced based on its own requirements, for example variation in the hours of use and the environment in which it is used.

An **X** in the Scheduled Maintenance Table indicates that the activity described should be performed at that maintenance period.

When fitting fasteners, DO NOT apply thread-locking adhesive. A specific torque setting must be applied to the wheel nuts as detailed on page 77. For other bolts and fasteners, refer to the guidance on torque settings given on page 78.

NOTE

If further details are required on how to perform the Scheduled Maintenance actions on the engine, refer to the Kohler “KDI 1903TCR - KDI 2504TCR Owner Manual” for the engine, which is appended to the rear of this manual.

It is not necessary to perform Daily Maintenance if a higher level of maintenance has been performed in the preceding 24 hours.

	Task	Daily	Weekly	Monthly	3 Months (250 hrs)	6 Months (500 hrs)	12 Months (1000 hrs)
1	Cleaning						
a.	Clean the vehicle using water and degreaser, or a domestic detergent and water solution. Do not use industrial cleaning agents, or caustic agents, or aircraft de-icing and cleaning agents. Use of a spray washer is permitted.	X	X	X	X	X	X
b.	Remove dirt and dust from the top surface of the battery and clean each battery terminal.				X	X	X
<p>WARNING – COMPRESSED AIR</p> <div style="display: flex; align-items: center;">  <p>Compressed air used for cleaning can create airborne particles that may enter the eyes. Wear Personal Protective Equipment (PPE) including eye shields or protective goggles, and suitable protective gloves. The pressure of the compressed air must not exceed 0.7 Bar (10 lbf sq in.).</p> </div>							
c.	Using a clean, dry, low pressure compressed air jet, clean the radiator surfaces. If the surfaces of the radiator are clogged with dirt or debris, clean the radiator surfaces				X	X	X

	Task	Dail y	Wee kly	Mon thly	3 Mont hs (250 hrs)	6 Mon ths (500 hrs)	12 Mont hs (1000 hrs)
	with a brush soaked in a domestic detergent and water solution.						
d.	Wipe oil, dirt and dust from wires and electrical harnesses in the engine compartment.					X	X
e.	If significant corrosion is present, grind off the corrosion, coat the affected area with corrosion protection fluid (if available), apply primer paint, and retouch paintwork.						X
2	Visual Inspection						
a.	Walk around the Belt Loader and examine the Belt Loader for the following. During the inspection tighten any fasteners that are loose.	X	X	X	X	X	X
b.	As you walk around the Belt Loader, check that all Warning labels are present and readable. Replace lost or unreadable Warning labels.		X	X	X	X	X
c.	Check body and driver's compartment are undamaged. Check that the Belt Frame Assembly is undamaged. Damage that may impair or affect the safe operation of the Belt Loader must be repaired before operating the Belt Loader.	X	X	X	X	X	X
d.	Check wing mirrors are present and undamaged. Replace missing or damaged mirrors.	X	X	X	X	X	X
e.	Check that the headlamps, front indicator lights, side indicator lights, rear indicator lights, and rear lights are present and undamaged. Check that the Front Work Light (located on the Belt Frame) is present and undamaged. Switch ON the ignition and check that all the lights work. Repair or replace any that are not serviceable. DO NOT use a Belt Loader with an unserviceable light.	X	X	X	X	X	X
f.	Check that the Beacon is present, secure, and undamaged. Check that the Beacon functions correctly. Replace or repair if unserviceable. DO NOT use a Belt Loader with an unserviceable Beacon.	X	X	X	X	X	X
g.	Check that the front and rear lowering lugs are undamaged. Repair if required.	X	X	X	X	X	X
h.	Check that the four lifting lugs on the vehicle body are undamaged. Repair if required.	X	X	X	X	X	X
	Check that the labels that identify each of the lifting lugs are present and undamaged.			X	X	X	X

	Task	Daily	Weekly	Monthly	3 Months (250 hrs)	6 Months (500 hrs)	12 Months (1000 hrs)
i.	Check tires for leaks and damage. Check surface condition of tires. Check tires meet legal requirements for minimum tread depth. Replace if damaged or worn-out.	X	X	X	X	X	X
j.	Check tightness of wheel nuts. Front wheels :274 to 323 Nm (202 to 239 ft/lbs). Rear wheels: 274 to 323 Nm (202 to 239 ft/lbs). Re-tighten if required.		X	X			X
k.	Check pressure of front tires is 72.5 ± 3 psi (5.0 ± 0.21 Bar (gauge)) (0.5 ± 0.021 MPa). Adjust tire pressure if required.	X	X	X	X	X	X
l.	Check pressure of rear tires is 72.5 ± 3 psi (5.0 ± 0.21 Bar (gauge)) (0.5 ± 0.021 MPa). Adjust tire pressure if required.	X	X	X	X	X	X
m.	Check that a label specifying the tire pressure is in position above each wheel.	X	X	X	X	X	X
n.	Check condition of conveyor belt. A damaged conveyor belt will impair or affect the safe operation of the Belt Loader and must be repaired before operating the Belt Loader.	X	X	X	X	X	X
o.	Check rubber bumper on front of Belt Frame Assembly is present, secure, and serviceable. Replace missing or damaged rubber bumper before using the Belt Loader.	X	X	X	X	X	X
p.	Check both proximity sensors on front of the Belt Frame Assembly are present, secure, and undamaged. Check wiring harness to proximity sensor is undamaged. Replace missing or damaged components before using the Belt Loader.	X	X	X	X	X	X
q.	Check Belt Frame Locking Pin is present and secured by a chain to the Belt Frame Assembly. Do not use the Belt Loader, or perform maintenance or servicing beneath the Belt Frame Assembly, if the pin is missing.	X	X	X	X	X	X
r.	Check for overheating of the rear axle. Investigate and repair any problems found.	X	X	X	X	X	X

WARNING – BURN HAZARD



Hot water in the radiator will scald. Make sure that the engine has cooled down before removing the radiator cap. Wear Personal Protective Equipment (PPE) including eye shields or protective goggles, and suitable protective gloves.

	Task	Dail y	Wee kly	Mon thly	3 Mont hs (250 hrs)	6 Mon ths (500 hrs)	12 Mont hs (1000 hrs)
s.	Check coolant level. Add coolant if required.	X	X	X	X	X	
t.	Replace coolant.						X
u.	Check engine oil level. Add oil as required. Refer to the Fuel, Lubricants and Consumables section of this manual for details of the engine oil.	X	X	X	X	X	X
v.	Check the fuel level. Refuel Belt Loader if necessary.	X	X	X	X	X	X
3	Seat Belt Checks The driver must check the condition and function of the seat belt each day, BEFORE using the BL30D. Only regular inspections can detect seat belt failures before a critical incident.						
a.	Pull the seat belt fully out and inspect its surface fibres for wear or fraying. If wear or fraying is found, report the problem, and DO NOT use the Belt Loader until the seat belt has been replaced.	X	X	X	X	X	X
b.	Check that the seat belt buckle functions correctly. Check that the retractor properly tightens the seat belt. If not, report the problem, and DO NOT use the Belt Loader until the seat belt has been replaced.	X	X	X	X	X	X
c.	Check the seat belt cover for damage. If damaged, report the problem, and DO NOT use the Belt Loader until the seat belt has been replaced.	X	X	X	X	X	X
d.	With the vehicle parked on flat ground, pull the seat belt out quickly. Make sure that the seat belt automatic locking device locks the seat belt. If the locking device does not lock the seat belt, report the problem, and DO NOT use the Belt Loader until the seat belt has been replaced.	X	X	X	X	X	X
4	Operation Check that the driver's compartment controls and indicators are undamaged. If any are damaged, report the problem and DO NOT use the Belt Loader until it has been repaired.	X	X	X	X	X	X
a.	Start the engine. Check the operation of the steering, and both braking systems. If not functioning correctly, report the problem and DO NOT use the Belt Loader until it has been repaired.	X	X	X	X	X	X

	Task	Dail y	Wee kly	Mon thly	3 Mont hs (250 hrs)	6 Mon ths (500 hrs)	12 Mont hs (1000 hrs)
b.	Check the operation of the electrical system. Check that all readings on the Dash Display Screen are normal. If there is a problem, report the problem and DO NOT use the Belt Loader until it has been repaired.	X	X	X	X	X	X
c.	Listen to the sound of the engine when it is idling, at medium speed and at high speed. If you hear anything unusual in the sound of the engine, report the problem.		X	X	X	X	X
5	Mechanical Checks						
a.	Check radiator and water hoses for leaks. Check radiator cap is present and secure. Replace leaking components.		X	X	X	X	X
b.	Check water hoses Replace water hoses if they show any sign of abrasion, delamination, or damage. Max life of hoses is five years.						X
c.	Clean Air Filter Cartridge. Examine Air Filter Cartridge and replace if damaged. NOTE this action may need to be done more frequently, depending upon the operating conditions.		X	X	X	X	X
d.	Replace Air Filter Cartridge. NOTE this action may need to be done more frequently, depending upon the operating conditions.					X	X
e.	Check fuel lines for leaks. Replace leaking components.		X	X	X	X	X
f.	Carefully examine fuel line to engine. Replace fuel line if shows any sign of abrasion, delamination, or damage.					X	X
g.	Check condition and tightness of fan belt. If necessary, replace fan belt, and/or check and replace tensioner.			X	X	X	X
h.	For engines with a standard alternator belt, check tightness of alternator belt. If necessary, adjust tension of alternator belt.				X		
k.	Check brake fluid level. Top-up brake fluid as required. Refer to the Fuel, Lubricants and Consumables section of this manual for details of the brake fluid.		X	X	X	X	X
i.	Replace brake fluid. Refer to the Fuel, Lubricants and Consumables section of this manual for details of the brake fluid.						X
j.	Check service brake system for leaks and brake pipes in poor condition.				X	X	X

	Task	Dail y	Wee kly	Mon thly	3 Mont hs (250 hrs)	6 Mon ths (500 hrs)	12 Mont hs (1000 hrs)
k.	Check condition and adjust clearance of brake shoes.						X
l.	Check, and if required, adjust the free stroke of the brake pedal and parking brake.					X	X
m.	Check parking brake cable. Replace if damaged or worn. Adjust if loose.			X	X	X	X
n.	Check power steering system for leaks.						X
o.	Check steering wheel and steering column for damage or other problems. Repair if required. Check play clearance of steering wheel and adjust if required. If necessary, tighten the steering system.						X
p.	Check Power Steering System steering cylinder. Replace if damaged or leaking hydraulic fluid.			X	X	X	X
q.	Check engine, Transmission, and Drive Axle for oil leaks. Repair any leaks found.		X	X	X	X	X
r.	Check Transmission fluid (oil) level. Top-up fluid as required. Refer to the Fuel, Lubricants and Consumables section of this manual for details of the Transmission oil.			X	X	X	X
s.	Replace Transmission oil filter.					X	X
t.	Replace Transmission oil. Refer to the Fuel, Lubricants and Consumables section of this manual for details of the Transmission oil.						X
u.	Replace engine oil. Refer to the Fuel, Lubricants and Consumables section of this manual for details of the engine oil.				X	X	X
v.	Check drive shaft bolts are present and secure. Check drive shaft is not loose. Replace bolts, or tighten bolts as required.			X	X	X	X
w.	Check drive shaft for damage or wear. Replace if required.			X	X	X	X
x.	Replace engine oil filter cartridge.				X	X	X
y.	Replace Drive Axle Differential Gear oil. Refer to the Fuel, Lubricants and Consumables section of this manual for details of the oil.						X
z.	Replace engine Fuel Filter/Water Separator cartridge.					X	X
aa.	Drain dirt and debris from fuel tank.						X
ab.	Replace in-tank fuel filter.						X
6	Hydraulic Checks						

	Task	Dail y	Wee kly	Mon thly	3 Mont hs (250 hrs)	6 Mon ths (500 hrs)	12 Mont hs (1000 hrs)
a.	Check Hydraulic System oil level. Top-up oil as required. Refer to the Fuel, Lubricants and Consumables section of this manual for details of the hydraulic oil.	X	X	X	X	X	X
b.	With the engine running, read gauge on Oil Return Filter: If the gauge needle reading is green, the filter element inside the Oil Return Filter is serviceable. If yellow or red, DO NOT operate the vehicle until the filter element has been cleaned or replaced.	X	X	X	X	X	X
c.	Check hydraulic oil tank associated hydraulic system hoses for leaks. Repair any leaks found – leaking hydraulic hoses must be replaced.	X	X	X	X	X	X
d.	Check Integrated Hydraulic Valve Assembly and associated hydraulic system hoses for leaks. Repair any leaks found – leaking hydraulic hoses must be replaced.	X	X	X	X	X	X
e.	Check hydraulic oil pump and associated hydraulic system hoses for leaks. Repair any leaks found – leaking hydraulic hoses must be replaced.	X	X	X	X	X	X
f.	Check Oil Return Filter element as described in the Fuel, Lubricants and Consumables section of this manual.					X	X
g.	Examine hydraulic lift cylinders, attached solenoid valves, and associated hydraulic hoses for oil leaks and damage. Report any faults and do not use the Belt Loader until they are repaired.	X	X	X	X	X	X
h.	Examine hydraulic motor (on Belt Frame Assembly) and associated hydraulic hoses for oil leaks and damage. Report any faults and do not use the Belt Loader until they are repaired.	X	X	X	X	X	X
i.	Check that the raise and lower functions for both the front and rear of the Belt Frame Assembly work correctly.	X	X	X	X	X	X
j.	Check conveyor belt operates correctly. If not, Report fault and do not use Belt Loader until it is repaired.	X	X	X	X	X	X
k.	Replace hydraulic oil. Refer to the Fuel, Lubricants and Consumables section of this manual for details of the oil, and the procedure for replacing the hydraulic oil.						X
7	Electrical Checks						
a.	Examine wires and electrical harnesses for damage or abrasion to the insulation, and loose connections.					X	X

	Task	Daily	Weekly	Monthly	3 Months (250 hrs)	6 Months (500 hrs)	12 Months (1000 hrs)
b.	Check that alternator and starter are secure and in a satisfactory working condition. Associated electrical wiring must be secure and undamaged. Replace if necessary.					X	X
8	Lubrication						
a.	Lubricate Belt Loader in accordance with the Lubrication Chart (if not already done in this maintenance sequence).		X	X	X	X	X
9	Maintenance Records						
a.	Complete all required maintenance records.	X	X	X	X	X	X

HYDRAULIC HOSES

High-pressure hydraulic hoses have a maximum service life of six years. Replace all high-pressure hoses on the BL30D every six years.

If a hydraulic component is replaced, all high-pressure hydraulic hoses associated with that hydraulic component should be replaced at the same time.

PRECAUTION – LIFE OF HIGH-PRESSURE HYDRAULIC HOSES



Replace all high-pressure hoses on the BL30D every six years.

When replacing a hydraulic component, replaced associated high-pressure hydraulic hoses at the same time.

COLD/HOT WEATHER MAINTENANCE

When the seasons change, perform the following cold weather/hot weather maintenance:

- Perform “Monthly Maintenance”.
- Clean fuel filter.
- Drain engine oil and replace with oil that is suitable for the coming cold or hot weather. Refer to the Fuel, Lubricants and Consumables section of this manual for details of an appropriate oil.

- Before cold weather arrives, drain the radiator and cooling system. Flush the cooling system with clean water. Then refill with an appropriately rated anti-freeze solution that includes industrial ethylene glycol.
- Before hot weather arrives, drain the radiator and cooling system. Flush the cooling system with clean water. Then refill with an appropriately rated coolant.
- Record that this maintenance has been completed.

WHEEL NUT TIGHTENING

When replacing a tire or checking the tightness of the Wheel Nuts during Scheduled Maintenance, tighten the Wheel Nuts in the order shown in the illustration below.

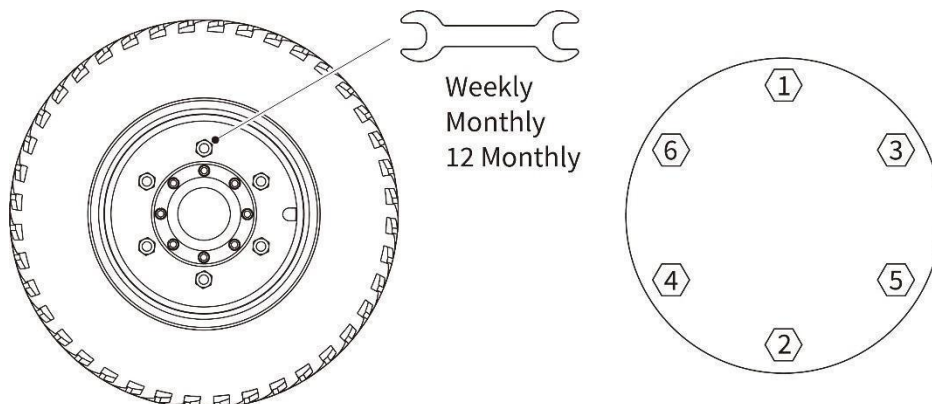

Fig 19 - Wheel Nut tightening

FUEL, LUBRICANTS AND CONSUMABLES

Fuel/Lubricant	Specification	Use
Fuel	Diesel	Fuel
Engine oil	API CJ-4 Synthetic 5W-30/10W-40 Diesel Oil.	Engine lubrication
Coolant	50/50 mix of distilled water and Coolant meeting GM Spec GM6277M (suitable for use down to -45 deg C/ - 49 deg F)	Engine cooling system
Hydraulic oil	L-HM32 hydraulic oil (-20 deg C/ -4 deg F and above) L-HV22 hydraulic oil (-40 deg C/ -40 deg F and above)	Vehicle hydraulic system Power Steering System
Transmission Fluid	ATF Dextron II or better	Transmission
Gear oil	GL-5 80W/90 or GL-5 Heavy Duty	Drive Axle Differential
Synthetic Brake Fluid	Mobil DOT4 Brake Fluid	Brake system
Grease	3# (Grade 3) Lithium based grease	Wheel hubs, bearings, bushings, Universal Joints, other moving mechanical parts

NOTE

To achieve optimum engine performance and durability, it is important that you only use engine lubricating oils displaying the American Petroleum Institute (API) "CJ-4 Synthetic 5W-30/10W-40 Diesel Oil." on the container.

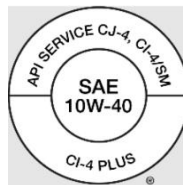

FILL CAPACITIES

Item	Fill capacities (L)
Fuel tank	80
Engine oil (with oil filter)	7.5 Start engine and allow to warm up before topping-up engine oil
Transmission oil	8.0 fill Then start engine, allow to warm-up, and top up oil to level on dipstick)
Hydraulic System oil (inc. Power Steering)	65.0
Drive Axle Differential oil	7.5
Brake fluid	1.4
Grease	As required
Coolant	10.0

CONSUMABLES

Consumable	Type
Engine Air Filter Element	PRPW00420
Engine Oil Filter Cartridge	PRPW00553 (Cummins) PRPW00426 (Kholer)
In-tank Fuel Filter	PRPW00070
Transmission Oil Filter	PRPW02232
Fuel Filter	PRPW00092 (Cummins) PRPW02243(Kholer)
Oil Suction Fiter (in hydraulic oil tank)	PRPW03255
Filter Element, Hydraulic (in Oil Return Filter attached to hydraulic oil tank)	PRPW02712
Access Cover Gasket, 300 x 5.3 mm	8KB00-80053
Wash oil	Same type of oil as will be used to refill the hydraulic system
Thread sealant	Any type suitable for hydraulic connections (purchase locally)

PAGE INTENTIONALLY LEFT BLANK

LUBRICATION DIAGRAM

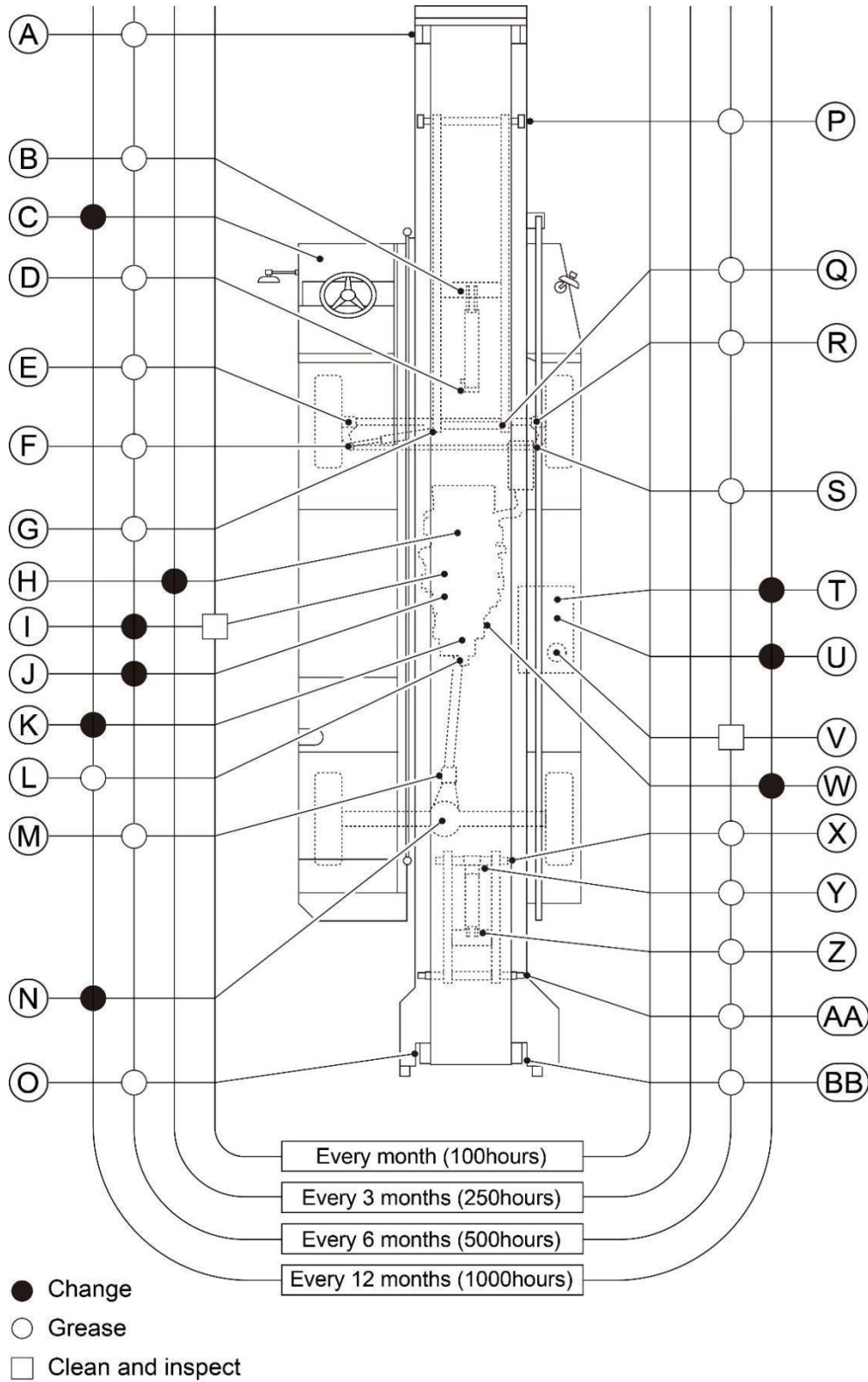

A	Front Roller Bearings - both sides	O	Rear Roller Self Aligning Bearing
B	Front Lift Cylinder – Upper Pin	P	Front Lifting Frame Rollers – both sides
C	Brake fluid	Q	Front Lifting Frame - Lower Bearing Seat
D	Front Lift Cylinder – Lower Pin	R	Front Axle RH Steering Knuckle
E	Front Axle LH Steering Knuckle	S	Ball Joint RH
F	Ball Joint LH (Steering Cylinder)	T	Hydraulic System oil
G	Steering Cylinder joint	U	Oil Suction Filter – Hydraulic System
H	Engine oil and Engine Oil Filter cartridge	V	Oil Return Filter – Hydraulic System
I	Air Filter cartridge	W	Transmission Suction Strainer
J	Fuel filter	X	Rear Lifting Frame – Lower Bearings - both sides
K	Transmission Oil and Transmission Oil Filter	Y	Rear Lift Cylinder – Lower Pin
L	Drive Shaft – Front Joint	Z	Rear Lift Cylinder – Upper Pin
M	Drive Shaft – Rear Joint	AA	Rear Lifting Frame – Upper Bearings – both sides
N	Drive Axle Differential gear oil	BB	Rear Roller Bearing Seat

Key to Lubrication diagram

NOTES

Air Filter element. The Air Filter element has an expected life of 300 to 500 hours depending upon environmental conditions. However, arduous operating conditions may affect service intervals and the life of the Air Filter element may be considerably less. Clean and inspect the Air Filter element monthly and replace if necessary. Do not exceed 500 hours use.

Engine oil and filter. The engine oil and filter must be changed every 250 hours or 3 months, whichever occurs first. The engine oil and filter should be changed more frequently if the Belt Loader is operating in dusty or extremely dirty areas, or during cold weather.

Hydraulic system oil suction filter. The oil suction filter located inside the hydraulic oil tank must be changed whenever the hydraulic oil is changed.

CLEANING/REPLACING THE OIL RETURN FILTER ELEMENT

Clean, inspect, and if necessary, replace, the filter element in the Oil Return Filter as follows:

- Refer to Figure 20 below. On the Oil Return Filter, unlock the plastic cover by rotating the plastic cover counter-clockwise. Then pull the plastic cover off the Oil Return Filter.

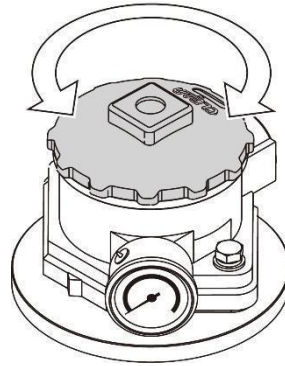

Figure 20 - Oil Return Filter cover

- Refer to Figure 21. A semi-circular steel lifting ring is provided on top of the filter element. Using the lifting ring, pull the filter element out of the Oil Return Filter.

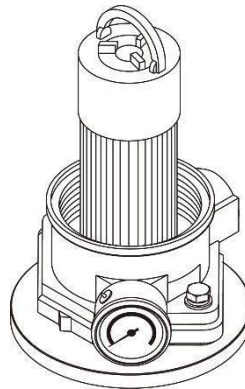

Figure 21 - Removing the oil return filter element

- Clean and inspect the filter element. Replace the filter element if it is damaged.
- Fit the cleaned/replacement filter element into the Oil Return Filter Assembly.
- Refer to Figure 20. Fit the plastic cover onto the Oil Return Filter and forcefully press the plastic cover down. Then lock the plastic cover in place by rotating it clockwise.
- The procedure for cleaning and/or replacing the oil return filter element is now complete.

REPLACEMENT OF HYDRAULIC OIL

The oil in the hydraulic system should be changed every 12 months. It is permitted to change the 12 month interval by $\pm 10\%$.

The normal service life of static hydraulic oil is approximately one year. In the spring and fall (autumn) the temperature difference between day and night is large. In those seasons, when a vehicle that has been working during the day halts for the night, the oil in the hydraulic tank is at a high temperature and the ambient air temperature is low. The hot air in the top of the oil tank meets the cold ambient temperature. Which causes the air in the oil tank to condense on the inside of the roof of the oil tank, forming water droplets that fall into the hydraulic oil. Over time the hydraulic oil will become mixed with water. Then it evolves into an acidic substance that corrodes metal surfaces. Under the dual action of mechanical operation and pipeline pressure shock, corroded metal particles will fall off metal surfaces and become mixed in the hydraulic oil. Metal particles greater in size than 10µm will be filtered out by an oil filter element, while particles smaller than 10µm will not be filtered out. The particles mixed in the hydraulic oil will increase the wear on metal surfaces. Therefore, do not leave the vehicle outside when it is not in use, especially in cold northern regions. Also, clean or replace the filter element in accordance with the maintenance schedule.

Before replacing the hydraulic oil, make sure that you have the following items available:

NOTE

When changing the type of hydraulic oil used on the BL30D Belt Loader, DO NOT mix the two types of hydraulic oil. All the previous type of hydraulic oil must be removed, and the hydraulic system thoroughly cleaned before filling with the new oil.

- Hydraulic oil. At least 100 L (22 gal), this being 1.5 times the capacity of the hydraulic system. Use the type of hydraulic oil specified in the Fuels, Lubricants and Consumables section of this manual.
- A replacement filter element for each filter in the hydraulic system. Only use the filter elements specified in the Fuels, Lubricants and Consumables section of this manual.
- Plugs to close the hydraulic pipes, etc.
- Thread sealant, suitable for high pressure hydraulic systems.
- An empty oil drum, or other container, with a capacity of at least 75 L (16.5 gal). A second container with a capacity of at least 10 L (2 gal).
- A new Access Cover Gasket, 300 x 5.3 mm, Part No. 8KB00-80053.
- Wash oil. Use the same type of oil as will be used to refill the hydraulic system. This is in addition to the oil to be used to refill the hydraulic system.
- A drain hose, with a M6-6H hydraulic connector on one end that will mate with the oil drain point on the piston (rod) end of each Hydraulic Cylinder.

Before replacing the hydraulic oil, make sure that the Belt Frame Assembly is in the fully lowered position, and the vehicle is switched Off.

Replace the hydraulic oil as follows:

WARNING – PETROLEUM, OILS AND LUBRICANTS



Do not eat, drink or smoke when applying oil or lubricant. Do not allow oil or lubricant to come into contact with your eyes, mouth or nose. Wear Personal Protective Equipment (PPE), for example suitable gloves, safety glasses, and overalls. If lubricant is ingested, or comes into contact with your eyes, seek medical assistance immediately.

Oil and lubricants are a slip hazard. Always clean up any spillages, or excess oil or lubricant.

- The vehicle must be parked on a flat surface. Make sure that at least two, and preferably all four, wheels and secured with chocks. Make sure that the area around the vehicle is completely clean.
- Place a container with a capacity of at least 75 L (16.5 gal) under the hydraulic oil tank.
- Refer to Figure 22 below. On the Hydraulic Oil Tank (1), remove the Oil Drain Plug (7) and allow the hydraulic oil to drain from the Hydraulic Oil Tank. Examine the Oil Drain Plug for cuts or delamination in the seal that forms part of the Oil Drain Plug and replace the Oil Drain Plug if its seal is damaged. Do not refit the Oil Drain Plug at this stage.

NOTE

Approximately three-quarters of the oil in the hydraulic system is stored in the hydraulic oil tank, with the remainder in the rest of the hydraulic system.

PRECAUTION – CONTAMINATION OF HYDRAULIC SYSTEM



To prevent any damage to the hydraulic components by contaminants, cover the oil tank access holes when not working in the oil tank.

Plug or cap all hydraulic connections immediately after disconnection and make sure that the connectors remain scrupulously clean until sealed.

- When the oil stops draining from the Oil Tank, it is necessary to drain the oil from the Hydraulic Cylinders and Gear Pump. Draining the oil from the Gear Pump is described later. Drain the oil from the two Hydraulic Cylinders as follows:
 - Refer to Figure 23. Remove and retain the M6 plug (2) from the oil drain point on the piston (rod) end of the Rear Hydraulic Cylinder (1).
 - Connect the M6-6H hydraulic connector of the drain hose to the oil drain point.
 - Route the other end of the drain hose into a container with a capacity of at least 10 L (2 gal) placed under the Rear Hydraulic Cylinder.
 - Start Up the vehicle. Operate the Rear Hydraulic Cylinder to discharge the oil from the piston side of the Hydraulic Cylinder.
 - When the oil stops draining from the Rear Hydraulic Cylinder, stop operating the Hydraulic Cylinder and Switch Off the vehicle. Refit the M6 plug (2) to the oil drain point.
 - Then repeat the process for the Front Hydraulic Cylinder.
 - Dispose of the waste oil in accordance with all National and local Laws, Regulations, and Codes; and the airports Environmental Policy.

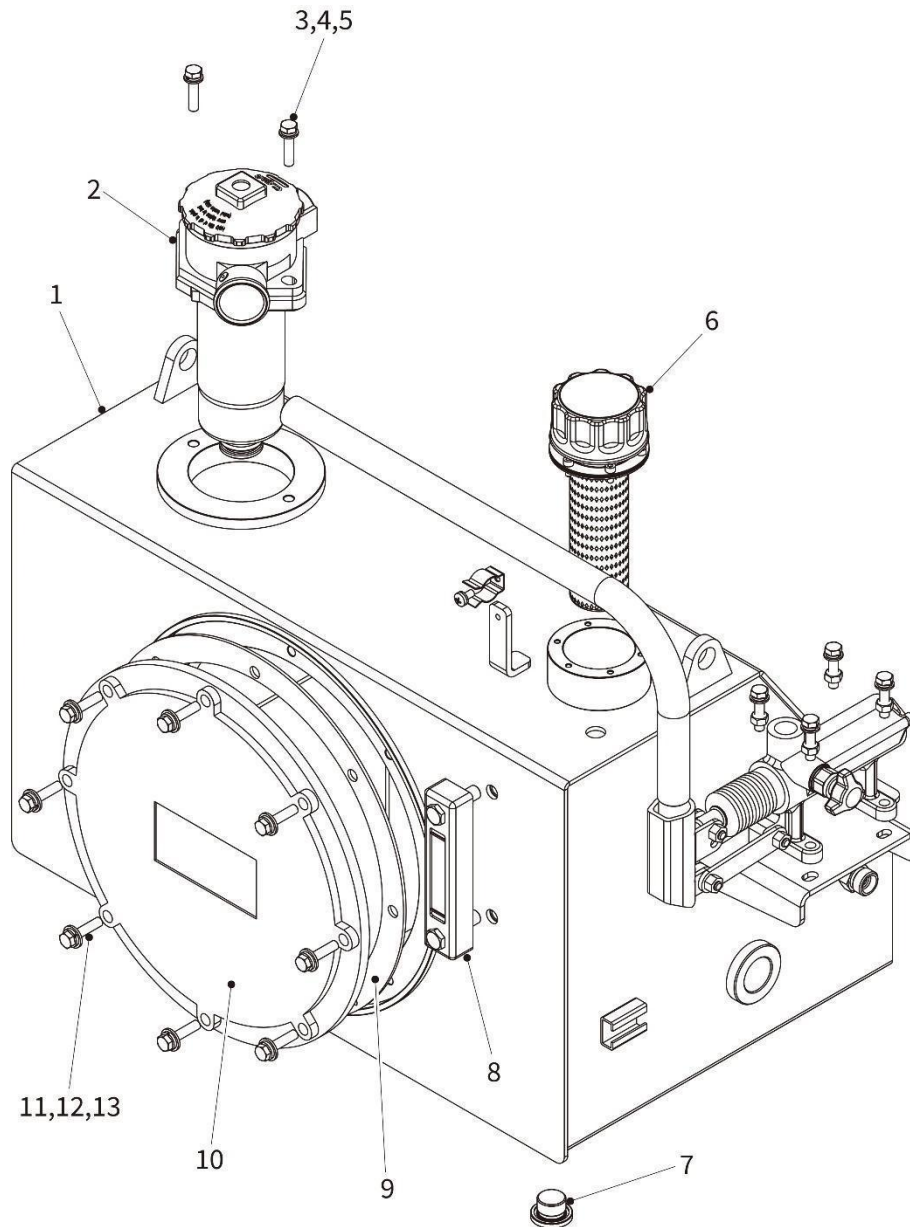

- | | | | |
|---|----------------------------|----|-----------------------------------|
| 1 | Oil Tank | 8 | Fluid Level Gauge |
| 2 | Oil Return Filter Assembly | 9 | Access Cover Gasket, 300 x 5.3 mm |
| 3 | M8 x 35 mm bolt | 10 | Access Cover, Oil Tank Cleaning |
| 4 | M8 lock washer | 11 | M10 x 35 mm bolt |
| 5 | M8 flat washer | 12 | M10 lock washer |
| 6 | Air Breather | 13 | M10 flat washer |
| 7 | Oil Drain Plug | | |

Fig 22 - Hydraulic Oil Tank

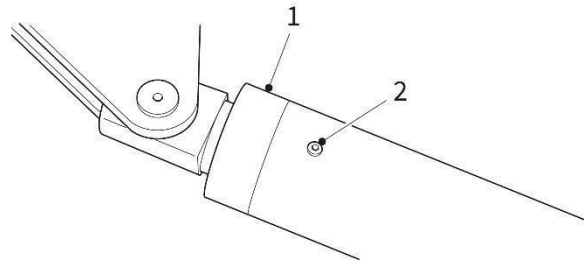

1 Hydraulic Cylinder

2 M6 plug

Fig 23 - Oil drain point on Rear Hydraulic Cylinder

- Refer to Figure 22. Remove and clean the air breather (6).
- Remove and retain the Qty. eight M10 x 35 mm bolts (11) and associated lock washers (12) and flat washers (13). Then remove the access cover (10) and associated access cover gasket (9). Retain the access cover. Discard the access cover gasket.
- Inside the Oil Tank, remove and discard the oil suction filter (not shown in Figure 22).
- Clean or replace the oil return filter element (as applicable) as described in the procedure above.
- Place a container with a capacity of at least 10 L (2 gal) under the Gear Pump.
- Disconnect the hydraulic pipe/hose connecting the Gear Pump to the Oil Tank, at the pump end. Allow the hydraulic oil to drain from the Gear Pump and the hydraulic pipe/hose.
- Dispose of the waste oil in accordance with all National and local Laws, Regulations, and Codes, and the airports Environmental Policy.
- Fit the Oil Drain Plug (7).
- Close the shut-off valve, located at the Oil Tank end of the hydraulic pipe/hose connecting the Gear Pump to the Oil Tank.
- Flush the Oil Tank and hydraulic piping with wash oil. When flushing the hydraulic piping:
 - Make sure that the wash oil always flows in the same direction.
 - Gently tap all the hydraulic pipes to release oxidation products and debris from the inside walls of the pipes.
 - Initially apply the minimum operating pressure to the wash oil, then gradually increase to normal operating pressure. Flush the system at normal operating pressure for 60 to 90 minutes.
 - Check the condition of the filter element in the Oil Return Filter. If there is no debris in the filter element, the flushing operation is complete. If any debris is found, clean the filter element and flush the system for another for 60 to 90 minutes.
- Place a container with a capacity of at least 75 L (16.5 gal) under the hydraulic oil tank. Remove the Oil Drain Plug (7) and allow the wash oil to drain out.
- Dispose of the waste oil in accordance with all National and local Laws, Regulations, and Codes, and the airports Environmental Policy.

- Fully open the shut-off valve, located at the Oil Tank end of the hydraulic pipe/hose connecting the Oil Tank to the Gear Pump.
- The interior of the Hydraulic Oil Tank must be thoroughly cleaned before refilling the hydraulic system.
 - Wipe the inside of the Oil Tank with a clean gauze cloth, or a clean, new, lint-free cloth. DO NOT use a cloth that may shed lint, or an old rag, as these will leave behind debris that can cause a blockage in the hydraulic system.
 - Clean the inside of the Oil Tank, twice, with a clean gauze cloth (or a clean, new, lint-free cloth) that has been soaked in diesel fuel (or similar).

WARNING – COMPRESSED AIR



Compressed air and the dust and debris that it generates can cause damage to the eyes and skin punctures. When using compressed air for cleaning, DO NOT use compressed air with a pressure above 0.7 Bar (10 p.s.i.). Wear Personal Protective Equipment (PPE): - safety glasses or eye shields, suitable gloves, and overalls. DO NOT use compressed air in a reckless manner.

If debris does enter your eyes, seek medical assistance immediately.

- Blow dry the exterior of the Oil Tank with a clean low pressure compressed air jet.
- Inside the Oil Tank, examine the edges and corners for residual sludge. Make sure that any residual sludge is removed and that the interior of the Oil Tank is completely clean.
- Then flush the Oil Tank with new oil.
- Inside the Oil Tank, install a new oil suction filter.
- Examine the O-ring seal on the Gear Pump inlet for damage and delamination. If necessary, replace the O-ring seal.
- When reconnecting hydraulic pipes and hoses, apply thread sealant to the thread surface to prevent leaks.
- Reconnect the hydraulic hose between the Gear Pump and the Oil Tank.
- Fit the air breather (6).
- Fit the access cover (10) and a new access cover gasket (9), and secure with Qty. eight M10 x 35 mm bolts (11) and associated lock washers (12) and flat washers (13). Lightly grease the gasket to assist the fitting and removal of the gasket and access cover.
- Fit the Oil Drain Plug (7).
- Fill the Oil Tank with clean, new, hydraulic oil through the oil port of the Oil Return Filter Assembly (2) until the Fluid Level Gauge (8) indicates that the Oil Tank is full.
- If not already done, fit the plastic cover onto the Oil Return Filter and forcefully press the plastic cover down. Then lock the plastic cover in place by rotating it clockwise.
- Start Up the vehicle. Hydraulic oil will flow into the Gear Pump, Hydraulic Cylinders, and hydraulic pipes and hoses, causing the oil level in the Oil Tank to drop.
- Switch Off the vehicle and top-up the oil level in the Oil Tank.

- Start Up the vehicle again. Operate all the hydraulic functions and verify that they all function correctly.
- Switch Off the vehicle. Check the oil level in the Oil Tank and top-up as necessary.
- The procedure for replacing the hydraulic oil is now complete, and the vehicle may be returned to use. After operating the vehicle for three to four hours, switch OFF the vehicle and check the condition of the filter element in the Oil Return Filter. Clean the filter element if any debris is found.

TROUBLESHOOTING AND FAILURE DIAGNOSIS

Troubleshooting and failure diagnosis on the BL30D Belt Loader may be performed as follows:

- The KDI 1903 TCR Engine includes a Built-In-Test (BIT) capability. If a problem occurs with the Engine, a fault code will appear on the Dash Display Screen (Instrument Panel) in the Driver’s Compartment.
- The “KOHLER Help File” appended to this manual describes the Engine fault codes; and provides detailed troubleshooting and failure diagnosis on the Engine including fault isolation and identification. For servicing and repair information for the Engine, refer to the “KDI 1903TCR - KDI 2504TCR Owner Manual” appended to this manual.
- Visually examine the Belt Loader for obvious problems, using the information given in the Scheduled Maintenance Table as a guide. Also check the ATM Mini Fuses in the Central Control Box.
- For suspected mechanical problems, other than with the Engine, Belt Frame Assembly, and hydraulic system, perform the Troubleshooting Procedure given in the Troubleshooting Table – Automotive Faults, below.
- For problems with the Belt Frame Assembly, hydraulic system, and electrical system, perform the Troubleshooting Procedure given in the Troubleshooting Table – Hydraulic, Electrical and Belt Frame Faults.
- In addition, for general electrical problems, a Diagnostic Trouble Code (DTC) may be displayed on the Dash Display Screen. Refer to the DTC Message Table for fault isolation and corrective action.

Appendix B. SAE Diagnostic Trouble Codes and Cummins Fault Codes

Fault Code	J1939 SPN	J1939 FMI	Lamp Color	Cummins Description	QSF2.8 Contains?
111	629	12	Stop (Solid)	Engine Control Module Critical Internal Failure - Bad intelligent device or component	Yes
115	612	2	Stop (Solid)	Engine Magnetic Speed/Position Lost Both of Two Signals - Data erratic, intermittent or incorrect	Yes
122	102	3	Warning (Solid)	Intake Manifold 1 Pressure Sensor Circuit - Voltage above normal, or shorted to high source	Yes
123	102	4	Warning (Solid)	Intake Manifold 1 Pressure Sensor Circuit - Voltage below normal, or shorted to low source	Yes
124	102	16	Warning (Solid)	Intake Manifold 1 Pressure - Data Valid But Above Normal Operating Range - Moderately Severe Level	Yes
131	91	3	Stop (Solid)	Accelerator Pedal or Lever Position Sensor 1 Circuit - Voltage above normal, or shorted to high source	Yes

Fault Code	J1939 SPN	J1939 FMI	Lamp Color	Cummins Description	QSF2.8 Contains?
132	91	4	Stop (Solid)	Accelerator Pedal or Lever Position Sensor 1 Circuit - Voltage below normal, or shorted to low source	Yes
133	974	3	Stop (Solid)	Remote Accelerator Pedal or Lever Position Sensor 1 Circuit - Voltage above normal, or shorted to high source	Yes
134	974	4	Stop (Solid)	Remote Accelerator Pedal or Lever Position Sensor 1 Circuit - Voltage below normal, or shorted to low source	Yes
135	100	3	Warning (Solid)	Engine Oil Rifle Pressure 1 Sensor Circuit - Voltage above normal, or shorted to high source	No
141	100	4	Warning (Solid)	Engine Oil Rifle Pressure 1 Sensor Circuit - Voltage below normal, or shorted to low source	No
143	100	18	Warning (Solid)	Engine Oil Rifle Pressure - Data Valid But Below Normal Operating Range - Moderately Severe Level	Yes
144	110	3	Warning (Solid)	Engine Coolant Temperature 1 Sensor Circuit - Voltage above normal, or shorted to high source	Yes
145	110	4	Warning (Solid)	Engine Coolant Temperature 1 Sensor Circuit - Voltage below normal, or shorted to low source	Yes
146	110	16	Warning (Solid)	Engine Coolant Temperature - Data Valid But Above Normal Operating Range - Moderately Severe Level	Yes
147	91	1	Stop (Solid)	Accelerator Pedal or Lever Position 1 Sensor Circuit Frequency - Data valid but below normal operational range - Most Severe Level	Yes
148	91	0	Stop (Solid)	Accelerator Pedal or Lever Position Sensor 1 - Data valid but above normal operational range - Most Severe Level	Yes
151	110	0	Stop (Solid)	Engine Coolant Temperature - Data valid but above normal operational range - Most Severe Level	Yes
153	105	3	Warning (Solid)	Intake Manifold 1 Temperature Sensor Circuit - Voltage above normal, or shorted to high source	Yes
154	105	4	Warning (Solid)	Intake Manifold 1 Temperature Sensor Circuit - Voltage below normal, or shorted to low source	Yes
155	105	0	Stop (Solid)	Intake Manifold 1 Temperature - Data valid but above normal operational range - Most Severe Level	Yes
187	3510	4	Warning (Solid)	Sensor Supply 2 Circuit - Voltage below normal, or shorted to low source	Yes

Fault Code	J1939 SPN	J1939 FMI	Lamp Color	Cummins Description	QSF2.8 Contains?
195	111	3	Warning (Solid)	Coolant Level Sensor 1 Circuit - Voltage above normal, or shorted to high source	Yes
196	111	4	Warning (Solid)	Coolant Level Sensor 1 Circuit - Voltage below normal, or shorted to low source	Yes
197	111	18	Warning (Solid)	Coolant Level Data Valid But Below Normal Operating Range Moderately Severe Level	Yes
221	108	3	Warning (Solid)	Barometric Pressure Sensor Circuit - Voltage above normal, or shorted to high source	Yes
222	108	4	Warning (Solid)	Barometric Pressure Sensor Circuit - Voltage below normal, or shorted to low source	Yes
227	3510	3	Warning (Solid)	Sensor Supply 2 Circuit - Voltage above normal, or shorted to high source	Yes
234	190	0	Stop (Solid)	Engine Crankshaft Speed/Position - Data valid but above normal operational range Most Severe Level	Yes
235	111	1	Stop (Solid)	Coolant Level - Data valid but below normal operational range Most Severe Level	Yes
238	3511	4	Warning (Solid)	Sensor Supply 3 Circuit - Voltage below normal, or shorted to low source	Yes
239	3511	3	Warning (Solid)	Sensor Supply 3 Circuit - Voltage above normal, or shorted to high source	Yes
241	84	2	Warning (Solid)	Wheel-Based Vehicle Speed - Data erratic, intermittent or incorrect	Yes
242	84	10	Warning (Solid)	Wheel-Based Vehicle Speed Sensor Circuit tampering has been detected - Abnormal rate of change	Yes
245	647	4	Warning (Solid)	Fan Control Circuit - Voltage below normal, or shorted to low source	Yes
271	1347	4	Warning (Solid)	Engine Fuel Pump Pressurizing Assembly 1 Circuit - Voltage below normal, or shorted to low source	Yes
272	1347	3	Warning (Solid)	Engine Fuel Pump Pressurizing Assembly 1 Circuit - Voltage above normal, or shorted to high source	Yes
285	639	9	Warning (Solid)	SAE J1939 Multiplexing PGN Timeout Error - Abnormal update rate	Yes
286	639	13	Warning (Solid)	SAE J1939 Multiplexing Configuration Error - Out Of Calibration	Yes

Fault Code	J1939 SPN	J1939 FMI	Lamp Color	Cummins Description	QSF2.8 Contains?
288	974	19	Stop (Solid)	SAE J1939 Multiplexing Remote Accelerator Pedal or Lever Position Sensor System - Received Network Data In Error	Yes
292	441	14	Stop (Solid)	Auxiliary Temperature Sensor Input 1 - Special Instructions	Yes
293	441	3	Warning (Solid)	Auxiliary Temperature Sensor Input 1 Circuit - Voltage above normal, or shorted to high source	Yes
294	441	4	Warning (Solid)	Auxiliary Temperature Sensor Input 1 Circuit - Voltage below normal, or shorted to low source	Yes
296	1388	14	Stop (Solid)	Auxiliary Pressure Sensor Input 2 - Special Instructions	Yes
322	651	5	Warning (Solid)	Injector Solenoid Driver Cylinder 1 Circuit - Current below normal or open circuit	Yes
323	655	5	Warning (Solid)	Injector Solenoid Driver Cylinder 5 Circuit - Current below normal or open circuit	No
324	653	5	Warning (Solid)	Injector Solenoid Driver Cylinder 3 Circuit - Current below normal or open circuit	Yes
325	656	5	Warning (Solid)	Injector Solenoid Driver Cylinder 6 Circuit - Current below normal or open circuit	No
331	652	5	Warning (Solid)	Injector Solenoid Driver Cylinder 2 Circuit - Current below normal or open circuit	Yes
332	654	5	Warning (Solid)	Injector Solenoid Driver Cylinder 4 Circuit - Current below normal or open circuit	Yes
343	629	12	Warning (Solid)	Engine Control Module Warning Internal Hardware Failure - Bad intelligent device or component	Yes
351	3597	12	Warning (Solid)	Injector Power Supply - Bad intelligent device or component	Yes
415	100	1	Stop (Solid)	Engine Control Module Warning Internal Hardware Failure - Bad intelligent device or component	Yes
418	97	15	Warning (Blinking)	Water in Fuel Indicator - Data Valid But Above Normal Operating Range - Least Severe Level	Yes
427	639	9	None	SAE J1939 Datalink - Abnormal update rate	Yes
428	97	3	Warning (Solid)	Water in Fuel Indicator Sensor Circuit - Voltage above normal, or shorted to high source	Yes

Fault Code	J1939 SPN	J1939 FMI	Lamp Color	Cummins Description	QSF2.8 Contains?
429	97	3	Warning (Solid)	Water in Fuel Indicator Sensor Circuit - Voltage below normal, or shorted to low source	Yes
431	558	2	Warning (Solid)	Accelerator Pedal or Lever Idle Validation Switch - Data erratic, intermittent or incorrect	Yes
432	558	13	Stop (Solid)	Accelerator Pedal or Lever Idle Validation Switch Circuit - Out of Calibration	Yes
435	100	2	Warning (Solid)	Engine Oil Rifle Pressure - Data erratic, intermittent or incorrect	Yes
441	168	18	Warning (Solid)	Battery 1 Voltage - Data Valid But Below Normal Operating Range Moderately Severe Level	Yes
442	168	16	Warning (Solid)	Battery 1 Voltage - Data Valid But Above Normal Operating Range Moderately Severe Level	Yes
449	157	0	Stop (Solid)	Injector Metering Rail 1 Pressure - Data valid but above normal operational range - Most Severe Level	Yes
451	157	3	Warning (Solid)	Injector Metering Rail 1 Pressure Sensor Circuit - Voltage above normal, or shorted to high source	Yes
452	157	4	Warning (Solid)	Injector Metering Rail 1 Pressure Sensor Circuit - Voltage below normal, or shorted to low source	Yes
471	98	17	Warning (Blinking)	Engine Oil Level - Data Valid But Below Normal Operating Range - Least Severe Level	No
523	611	2	Warning (Solid)	Auxiliary Intermediate (PTO) Speed Switch Validation - Data erratic, intermittent or incorrect	Yes
527	702	3	Warning (Solid)	Auxiliary Input/Output 2 Circuit - Voltage above normal, or shorted to high source	Yes
528	93	2	Warning (Solid)	Auxiliary Alternate Torque Validation Switch - Data erratic, intermittent or incorrect	Yes
529	703	3	Warning (Solid)	Auxiliary Input/Output 3 Circuit - Voltage above normal, or shorted to high source	Yes
553	157	16	Warning (Solid)	Injector Metering Rail 1 Pressure - Data Valid But Above Normal Operating Range - Moderately Severe Level	Yes

559	157	18	Warning (Solid)	Injector Metering Rail 1 Pressure - Data Valid But Below Normal Operating Range - Moderately Severe Level	Yes
584	677	3	Warning (Solid)	Starter Relay Driver Circuit - Voltage above normal, or shorted to high source	Yes

Fault Code	J1939 SPN	J1939 FMI	Lamp Color	Cummins Description	QSF2.8 Contains?
585	677	4	Warning (Solid)	Starter Relay Driver Circuit - Voltage below normal, or shorted to low source	Yes
599	640	14	Stop (Solid)	Auxiliary Commanded Dual Output Shutdown - Special Instructions	Yes
649	1378	31	Warning (Blinking)	Engine Oil Change Interval - Condition Exists	Yes
689	190	2	Warning (Solid)	Engine Crankshaft Speed/Position - Data erratic, intermittent or incorrect	Yes
697	1136	3	Warning (Solid)	Engine ECU Temperature Sensor Circuit - Voltage above normal, or shorted to high source	Yes
698	1136	4	Warning (Solid)	Engine ECU Temperature Sensor Circuit - Voltage below normal, or shorted to low source	Yes
731	723	7	Warning (Solid)	Engine Speed/ Position Camshaft and Crankshaft Misalignment - Mechanical system not responding or out of adjustment	Yes
778	723	2	Warning (Solid)	Engine Camshaft Speed/ Position Sensor - Data erratic, intermittent or incorrect	Yes
1117	3597	2	None	Power Supply Lost With Ignition On - Data erratic, intermittent or incorrect	Yes
1239	2623	3	Warning (Solid)	Accelerator Pedal or Lever Position Sensor 2 Circuit - Voltage above normal, or shorted to high source	Yes
1241	2623	4	Warning (Solid)	Accelerator Pedal or Lever Position Sensor 2 Circuit - Voltage below normal, or shorted to low source	Yes
1242	91	2	Stop (Solid)	Accelerator Pedal or Lever Position Sensor 1 - Data erratic, intermittent or incorrect	Yes
1515	91	19	Stop	J39_MUX ACCEL_DATA_ERROR	Yes

			(Solid)		
1539	1387	3	Warning (Solid)	OEM PRESSURE_HIGH_ERROR	Yes
1621	1387	4	Warning (Solid)	Auxiliary Pressure Sensor Input 1 Circuit - Voltage below normal, or shorted to low source	Yes
1695	3513	3	Warning (Solid)	Sensor Supply 5 - Voltage above normal, or shorted to high	Yes
1696	3513	4	Warning (Solid)	Sensor Supply 5 - Voltage below normal, or shorted to low	Yes

Fault Code	J1939 SPN	J1939 FMI	Lamp Color	Cummins Description	QSF2.8 Contains?
1852	97	16	Warning (Solid)	Water in Fuel Indicator - Data Valid But Above Normal Operating Range - Moderately Severe Level	Yes
2182	1072	3	Warning (Solid)	Engine Brake Actuator Driver 1 Circuit - Voltage above normal, or shorted to high source	Yes
2183	1072	4	Warning (Solid)	Engine Brake Actuator Driver 1 Circuit - Voltage below normal, or shorted to low source	Yes
2185	3512	3	Warning (Solid)	Sensor Supply 4 Circuit - Voltage above normal, or shorted to high source	Yes
2186	3512	4	Warning (Solid)	Sensor Supply 4 Circuit - Voltage below normal, or shorted	Yes
2311	633	31	Warning (Solid)	Electronic Fuel Injection Control Valve Circuit - Condition Exists	Yes
2321	190	2	None	Engine Crankshaft Speed/Position - Data erratic, intermittent or incorrect	Yes
2322	723	2	None	Engine Camshaft Speed/ Position Sensor - Data erratic, intermittent or incorrect	Yes
2377	647	3	Warning (Solid)	Fan Control Circuit - Voltage above normal, or shorted to high source	Yes
2442	651	13	Warning (Solid)	Injector Solenoid Driver Cylinder 1 - Out of Calibration	Yes
2443	652	13	Warning (Solid)	Injector Solenoid Driver Cylinder 2 - Out of Calibration	Yes

2444	653	13	Warning (Solid)	Injector Solenoid Driver Cylinder 3 - Out of Calibration	Yes
2445	654	13	Warning (Solid)	Injector Solenoid Driver Cylinder 4 - Out of Calibration	Yes
2446	655	13	Warning (Solid)	Injector Solenoid Driver Cylinder 5 - Out of Calibration	No
2447	656	13	Warning (Solid)	Injector Solenoid Driver Cylinder 6 - Out of Calibration	No
2448	111	17	Warning (Blinking)	Coolant Level - Data Valid But Below Normal Operating Range - Least Severe Level	Yes
2555	729	3	Warning (Solid)	Engine Intake Air Heater 1 Circuit - Voltage above normal, or shorted to high source	Yes

Fault Code	J1939 SPN	J1939 FMI	Lamp Color	Cummins Description	QS2.8 Contains?
2556	729	4	Warning (Solid)	Engine Intake Air Heater 1 Circuit - Voltage below normal, or shorted to low source	Yes
2963	110	15	None	Engine Coolant Temperature - Data Valid But Above Normal Operating Range - Least Severe Level	Yes
2964	105	15	None	Intake Manifold 1 Temperature - Data Valid But Above Normal Operating Range - Least Severe Level	Yes
3186	1623	9	Warning (Solid)	Tachograph Output Shaft Speed - Abnormal update rate	Yes
3213	1623	19	Warning (Solid)	Tachograph Output Shaft Speed - Received Network Data In Error	Yes
3326	91	9	Stop (Solid)	SAE J1939 Multiplexed Accelerator Pedal or Lever Sensor System - Abnormal update rate	Yes
3328	191	9	Warning (Solid)	Transmission Output Shaft Speed - Abnormal update rate	Yes
3418	191	19	Warning (Solid)	Transmission Output Shaft Speed - Received Network Data In Error	Yes
3525	84	19	Warning (Solid)	Wheel-Based Vehicle Speed - Received Network Data In Error	Yes

3526	84	9	Warning (Solid)	Wheel-Based Vehicle Speed - Abnormal update rate	Yes
3527	558	19	Stop (Solid)	Accelerator Pedal or Lever Idle Validation Switch - Received Network Data In Error	Yes
3528	558	9	Stop (Solid)	Accelerator Pedal or Lever Idle Validation Switch - Abnormal update rate	Yes
3535	1213	9	Warning (Solid)	Malfunction Indicator Lamp - Abnormal update rate	Yes
3613	111	9	Warning (Solid)	Coolant Level Sensor - Abnormal update rate	Yes
3614	111	19	Warning (Solid)	Coolant Level Sensor - Received Network Data In Error	Yes
3641	748	9	Warning (Solid)	Transmission Output Retarder - Abnormal update rate	Yes
3697	630	12	Warning (Solid)	Engine Control Module Calibration Memory - Bad intelligent device or component	Yes

Fault Code	J1939 SPN	J1939 FMI	Lamp Color	Cummins Description	QSF2.8 Contains?
3727	5571	7	None	High Pressure Common Rail Fuel Pressure Relief Valve-Mechanical system not responding or out of adjustment	Yes
3741	5571	0	Warning (Solid)	High Pressure Common Rail Fuel Pressure Relief Valve - Data valid but above normal operational range - Most Severe Level	Yes
3765	442	3	Warning (Solid)	OEM TEMPERATURE2_HIGH_ERROR	No
3766	442	4	Warning (Solid)	OEM TEMPERATURE2_LOW_ERROR	No

4526	521	2	Warning (Solid)	Brake Pedal Position - Data erratic, intermittent or incorrect	Yes
4642	97	0	Stop (Solid)	Water in Fuel Indicator - Data Valid But Above Normal Operating Range - Most Severe Level	Yes
4734	701	14	Stop (Solid)	Auxiliary Input/Output 1 - Special Instructions	Yes
4789	1639	0	Warning (Solid)	Fan Speed - Data Valid but Above Normal Operational Range Most Severe Level	Yes
4791	1639	1	Warning (Solid)	Fan Speed - Data Valid but Below Normal Operational Range Most Severe Level	Yes
6243	520973	4	Warning (Solid)	Forklift Mast Actuator Driver Circuit - Voltage Above Normal or Shorted to High Source	Yes
6242	520973	3	Warning (Solid)	Forklift Mast Actuator Driver Circuit - Voltage Above Normal or Shorted to High Source	Yes
6232	741	4	Warning (Solid)	Transmission 1 Forward Solenoid Valve Driver Circuit - Voltage Below Normal or Shorted to Low Source	Yes
6231	741	3	Warning (Solid)	Transmission 1 Forward Solenoid Valve Driver Circuit - Voltage Above Normal or Shorted to Low Source	Yes
6234	4216	4	Warning (Solid)	Transmission 1 Reverse Solenoid Valve Driver Circuit - Voltage Below Normal or Shorted to Low Source	Yes
6233	4216	3	Warning (Solid)	Transmission 1 Reverse Solenoid Valve Driver Circuit - Voltage Above Normal or Shorted to High Source	Yes
6236	768	4	Warning (Solid)	Transmission Range High Actuator Circuit - Voltage Below Normal or Shorted to Low Source	Yes
6235	758	3	Warning (Solid)	Transmission Range High Actuator Circuit - Voltage Above Normal or Shorted to Low Source	Yes

Fault Code	J1939 SPN	J1939 FMI	Lamp Color	Cummins Description	QSF2.8 Contains?
6229	920	4	Warning (Solid)	Audible Alarm Circuit - Voltage Below Normal or Shorted to Low Source	Yes
6229	920	3	Warning (Solid)	Audible Alarm Circuit - Voltage Above Normal or Shorted to High Source	Yes

ENGINE FAULT CODES

If a fault code is displayed on the Dash Display Screen (Instrument Panel), refer to the “KOHLER Help File.” appended to this manual.

REPAIR

Repair of the BL30D Belt Loader is by direct replacement of the faulty or damaged component. The Exploded Parts View illustrations show all the components and how the BL30D is dismantled and re-assembled. All the components are listed in the Parts Breakdown List and the numbers on the Exploded Parts View illustrations are keyed to the Parts Breakdown List.

Replacement parts should be sourced from Avro GSE. The use of major components not obtained from Avro GSE will invalidate the Warranty.

NOTE

It is expected that replacement fasteners may be sourced locally. If sourcing fasteners locally, make sure that the replacement fasteners are the same type and grade of material, and have the same protective coating, as the original. The Parts Breakdown List specifies the required material and finish.

The vehicle chassis is not available as a spare. Any significant damage to the vehicle chassis will almost certainly be part of catastrophic damage to the Belt Loader. Also, the time and effort required to strip down the Belt Loader, replace the chassis, and then rebuild, is such that significant damage to the Chassis renders the Belt Loader “Beyond Economic Repair”.

WHEEL NUTS

The wheel nuts that secure the left and right Rear Wheels are the same size, but have different threads, and are not interchangeable.

- When replacing a right-hand Rear Wheel, six Wheel Nut, M18 x 25 mm, Right-hand thread (Part No. TBA) must be used to secure the wheel. Rotate the nut counter-clockwise to loosen the nut, and rotate the nut clockwise to tighten it.
- When replacing a left-hand Rear Wheel, six Wheel Nut, M18 x 25 mm, Left-hand thread (Part No. TBA) must be used to secure the wheel. Rotate the nut clockwise to loosen the nut and rotate the nut counter-clockwise to tighten it.

NOTE

It is NOT possible to fit the wheel nuts from the right-hand Rear Wheel to the wheel studs of the left-hand Rear Wheel. Similarly, it is NOT possible to fit the wheel nuts from the left-hand Rear Wheel to the wheel studs of the right-hand Rear Wheel. Therefore, on the Rear Wheels the associated wheel nuts cannot be accidentally or deliberately fitted to the wrong wheel.

TORQUE VALUES

The wheel nuts MUST be torque tightened to the correct torque settings given below. Failure to torque tighten the wheel nuts to the correct torque setting may result in a wheel coming loose.

Wheel Nut torque values

Fastener	Torque setting
Front wheel nuts	210 Nm (155 ft/lbs)
Rear wheel nuts	420 Nm (310 ft/lbs)

For other securing bolts, refer to the general recommended torque values table given below next page. If in doubt about the strength grade of the bolt, use the lowest figure given for that size of bolt.

General recommended torque values

Bolt Strength Grade	4.6	5.6	8.8	10.9	12.9
Minimum yield strength		340 MPa	660 MPa	940 MPa	
Bolt Size	Recommended Torque				
mm	Nm	Nm	Nm	Nm	Nm
M2	0.11	-	0.29	0.41	0.43
M3	0.44	0.56	1.05	1.48	1.77
M4	1.00	1.28	2.44	3.04	3.65
M5	2.10	2.51	4.94	6.15	7.38
M6	3.51	4.30	9.00	13.00	15.00
M8	8.50	10.5	20.00	29.00	34.00
M10	17	21	40	57	68
M12	30	36	70	99	119
M14	47	56	112	116	139
M16	73	88	175	246	295
M18	101	121	241	338	406
M20	143	171	341	480	576
M22	195	230	464	652	783
M24	248	295	590	829	995
M27	362	435	863	1213	1456
M30	491	590	1171	1647	1977
M33	669	800	1594	2242	2690
M36	864	1030	2047	2879	3454
M39	1115	1340	2649	3726	4471
M42	1378	-	3274	4604	5525
M45	-	-	4072	5726	6871
M48	2064	-	4911	6906	8287
M52	-	-	6370	8958	10749

WELDING REPAIRS, GRINDING, AND CUTTING

If any weld repairs, grinding, cutting with power tools or cutting torches, or similar work is to be performed on a BL30D vehicle, the Safety Warnings and Precautions below **MUST** be complied with.

WARNINGS AND PRECAUTIONS – WELDING, GRINDING, AND CUTTING



WELDING ARC. A welding arc is bright enough to damage eyesight and cause flash burns. Never look directly at a welding arc with unprotected eyes. Always use an approved welding screen or visor. Cover all exposed skin before welding.



PROTECTIVE CLOTHING. Always wear protective clothing and gloves appropriate for welding work.



HOT WELDS. Always allow a weld to cool before removing welding slag.

Make sure that there is no combustible material within 4 Meters (13 feet) of grinding, welding, or slag chipping.



GRINDING, CHIPPING, AND CUTTING. Always wear eye protection (e.g. protective goggles) when using grinding and cutting tools, and when chipping off welding slag. Always wear eye protection when within 4 Meters (13 feet) of grinding, slag chipping, or cutting with power tools.



DAMAGE TO ELECTRICAL EQUIPMENT. To prevent damage to the vehicle electrical system, before performing any welding, remove or disconnect all vehicle batteries, and disconnect all electrical connections to the vehicle electronics.



TRAINING, AUTHORIZATION AND CERTIFICATION OF WELDERS. Welding must only be performed by people who have been **FULLY TRAINED IN WELDING AND ARE AUTHORIZED** to perform welding operations. Welders must be **CERTIFIED** by their respective national association of welders, such as CWB and/or AWS.

Grinding, chipping, and cutting with power tools must only be performed by people who have been **FULLY TRAINED IN USING THE POWER TOOLS AND ARE AUTHORIZED** to perform those operations.

Before performing any welding, grinding or chipping operations, make sure that any necessary Hot Work Permits have been obtained.

ELECTRICAL SCHEMATICS

These Electrical Schematics are provided to assist in troubleshooting.

This manual covers the build standard of BL30D Belt Loader that were manufactured during 2022-2023..

For a BL30D Belt Loader with a MY of 2022 and 2023, the following electrical diagrams are provided (in this sequence):

- BL30D Electrical Schematic 2022-2023 MY
- BL30D 2022-2023 MY Wiring Harness, Part No. PRPW02507
- BL30D 2022-2023 MY Belt Frame Harness, Part No. PRPW02404
- Dash Display Instrument, Part No. PRPW00408
- BL30D Central Control Box, Part No. PRPW0026
- BL30D Interlock Control Module, Part No. PRPW00014
- Ignition Switch Assembly, Part No. PRPW00051
- BL30D Gearshift/Turn Signal/Headlamp Control Assembly, Part No. PRPW02403

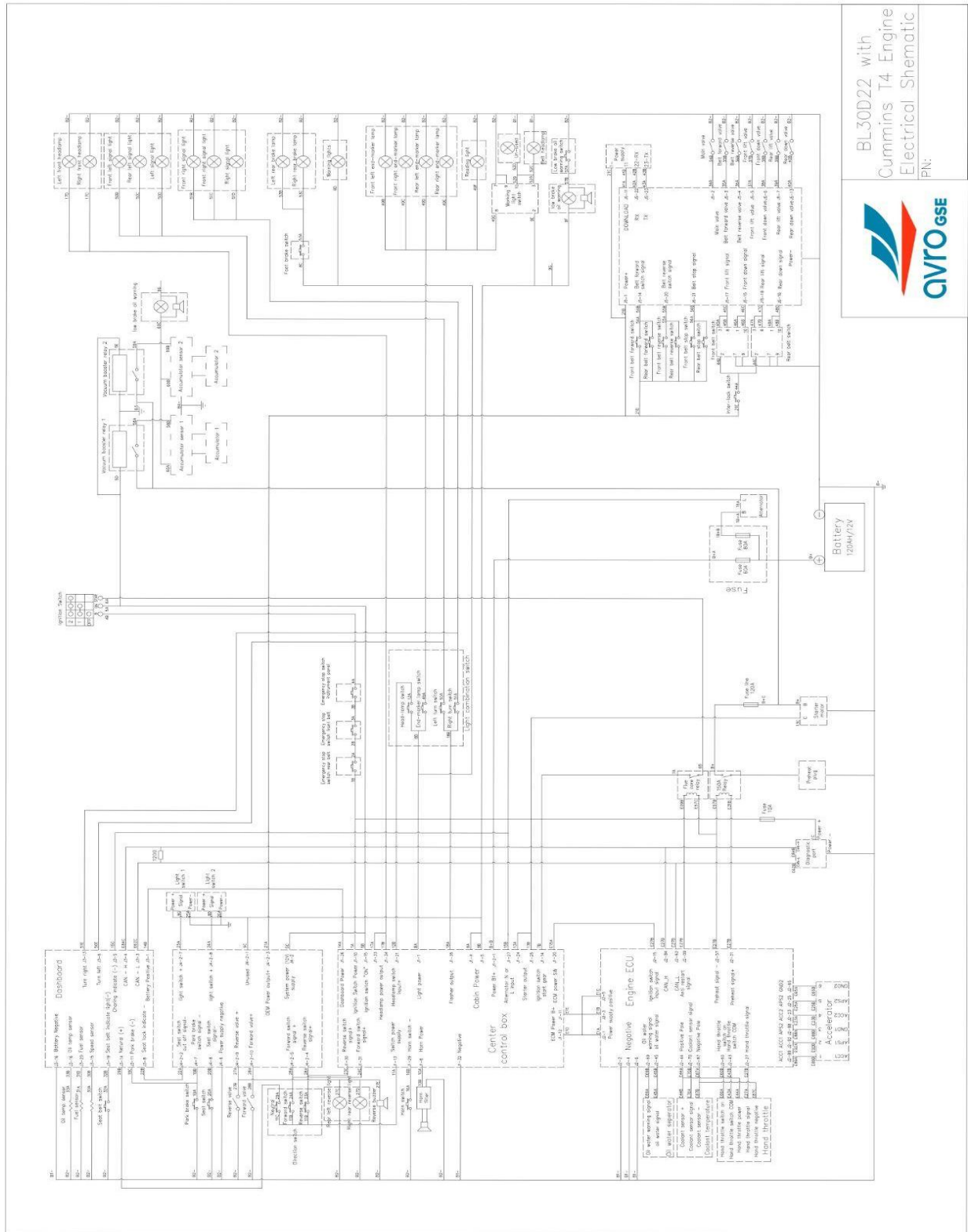

BL30D Belt Loader

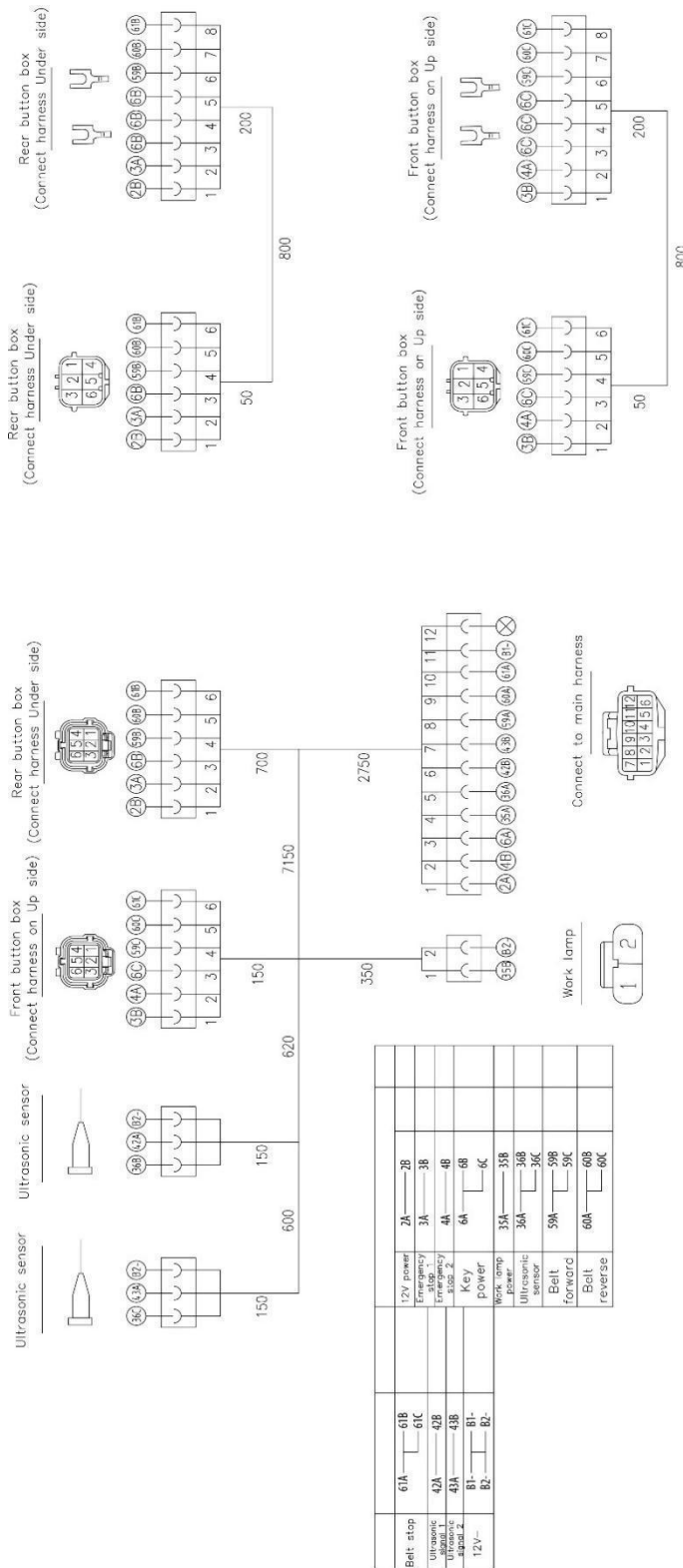

	TITLE:	BL30G 2022MY
		Beltframe Harness
	PN:	PRPW02404

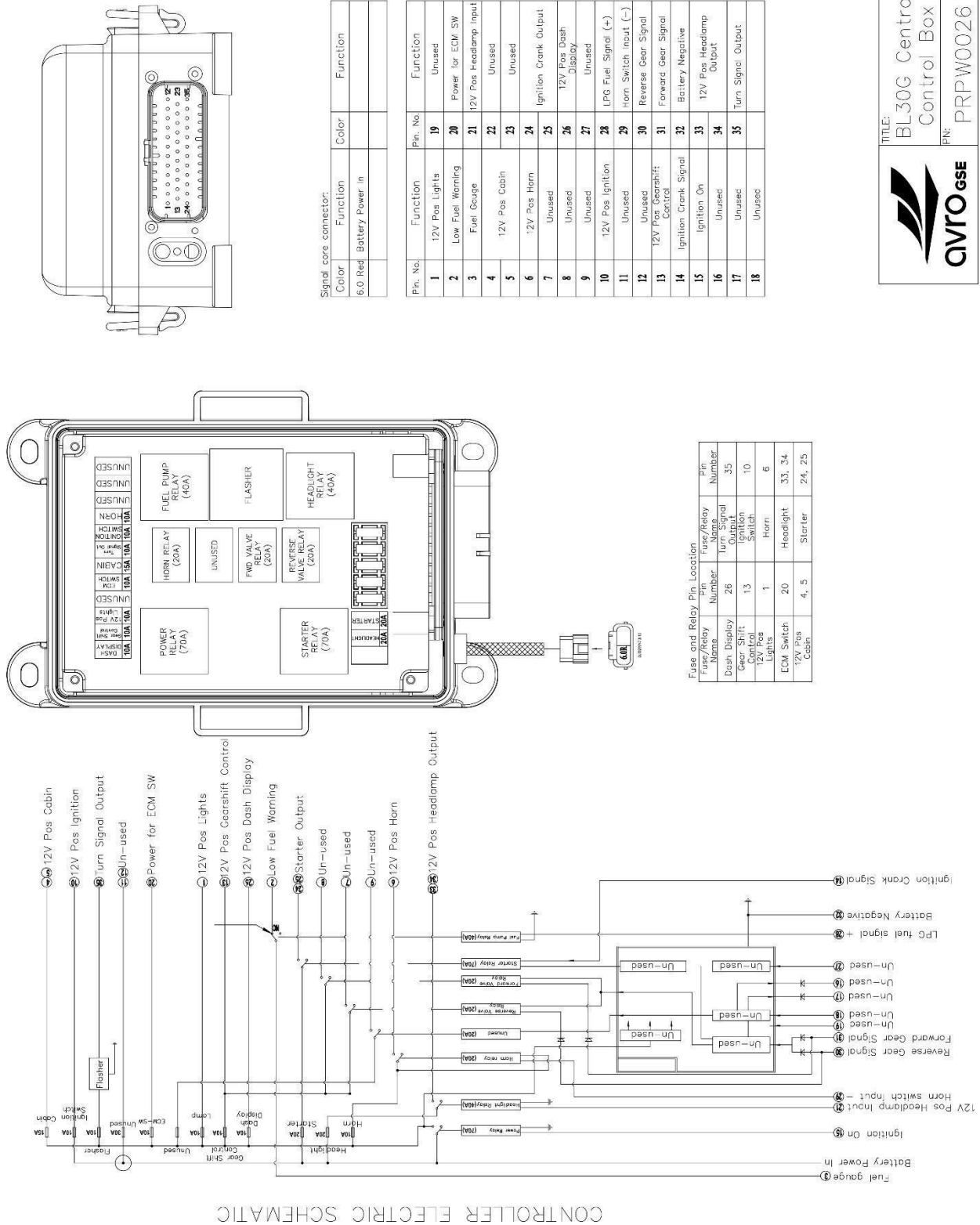

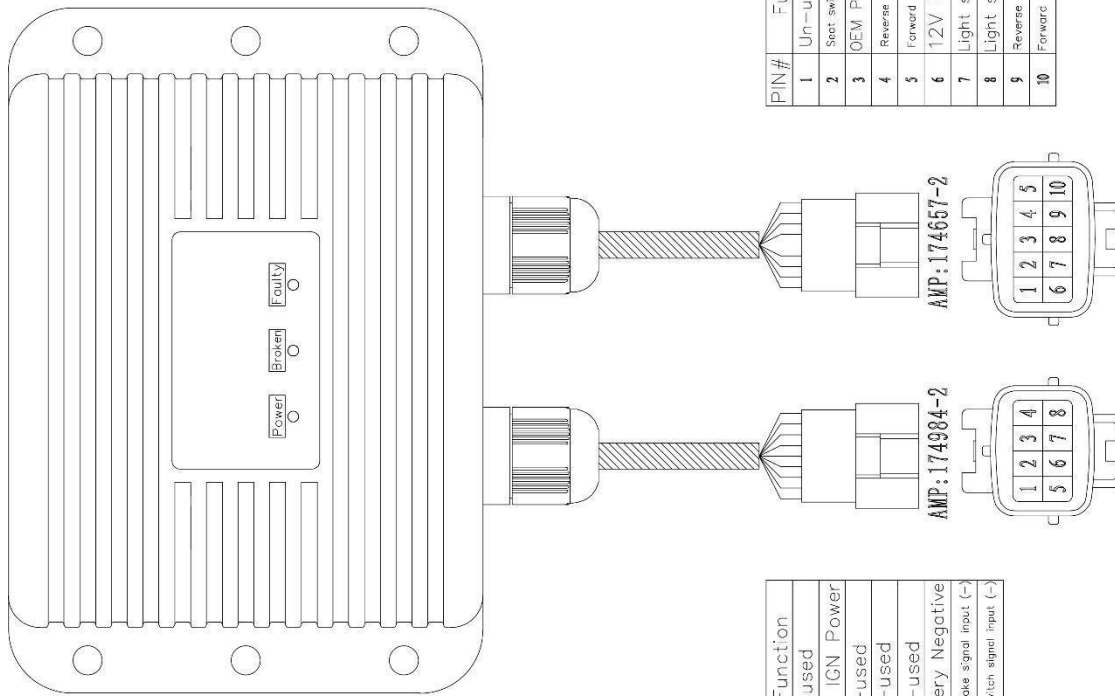

PIN#	Function
1	Un-used
2	12V IGN Power
3	Un-used
4	Un-used
5	Un-used
6	Battery Negative
7	Park brake signal input (-)
8	Seat switch signal input (-)

PIN#	Function
1	Un-used
2	Seat switch signal output
3	OEM Power output
4	Reverse switch input (+)
5	Forward switch input (+)
6	12V Pwr In
7	Light switch 2 (+)
8	Light switch 1 (+)
9	Reverse valve output (+)
10	Forward valve output (+)

	TITLE:	BL30C Interlock Control Module
	PIN:	PRPW00014

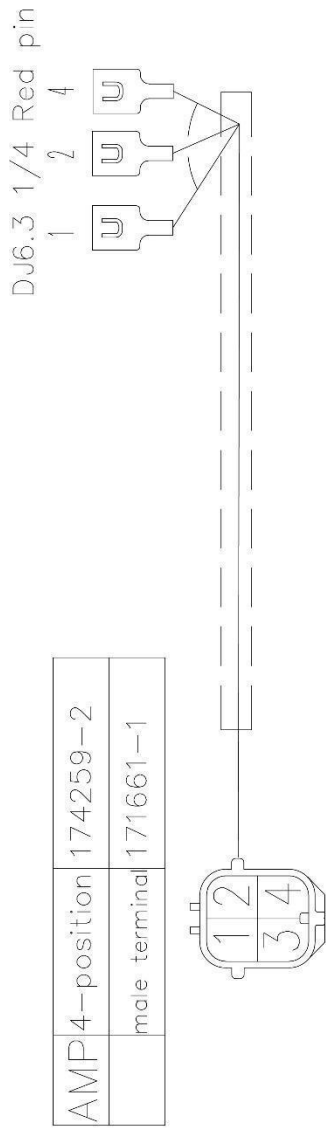

Terminal #	Function	Color/Gauge
1	BAT	RD/1.5mm ²
2	ACC	WT/1.5mm ²
4	START	WT/0.75mm ²

Ignition switch
part #: PRPW00051

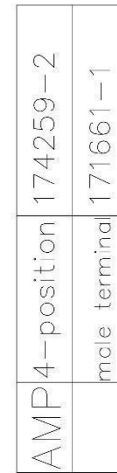
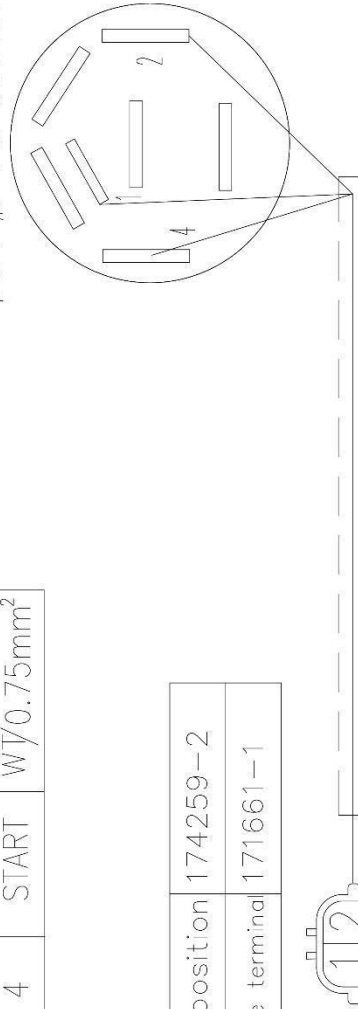

	TITLE:	Ignition Switch Assembly
	P/N:	PRPW00051

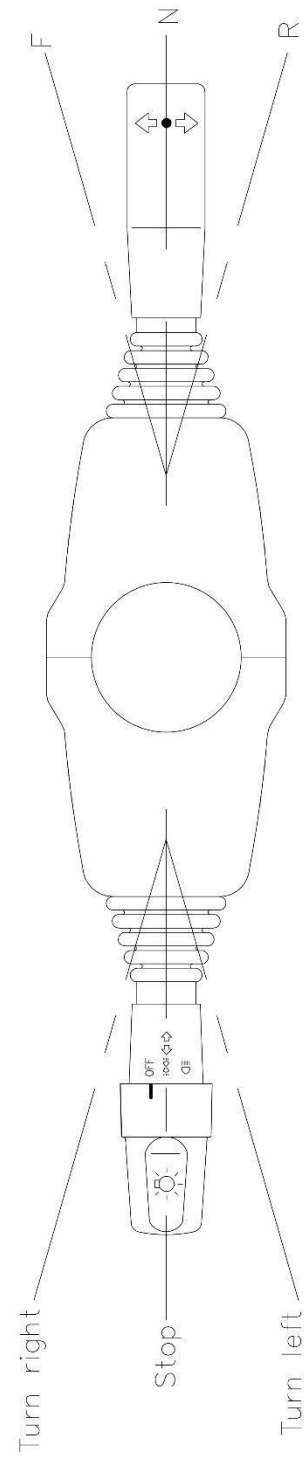
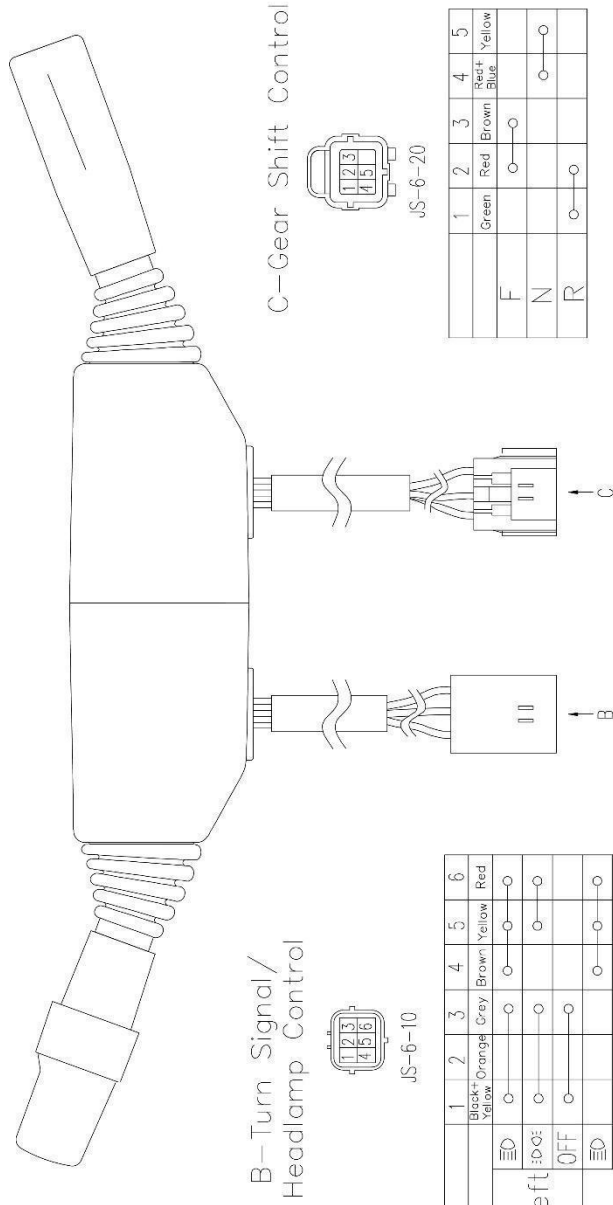

	TITLE:	BL30G Gearshift/Turn Signal/Headlamp Control - Assy.
	PN:	PRPW02403

HYDRAULIC SCHEMATIC

This Hydraulic Schematic is provided to assist in troubleshooting.

This manual covers the build standard of BL30D Belt Loader that were manufactured during 2022-2023.

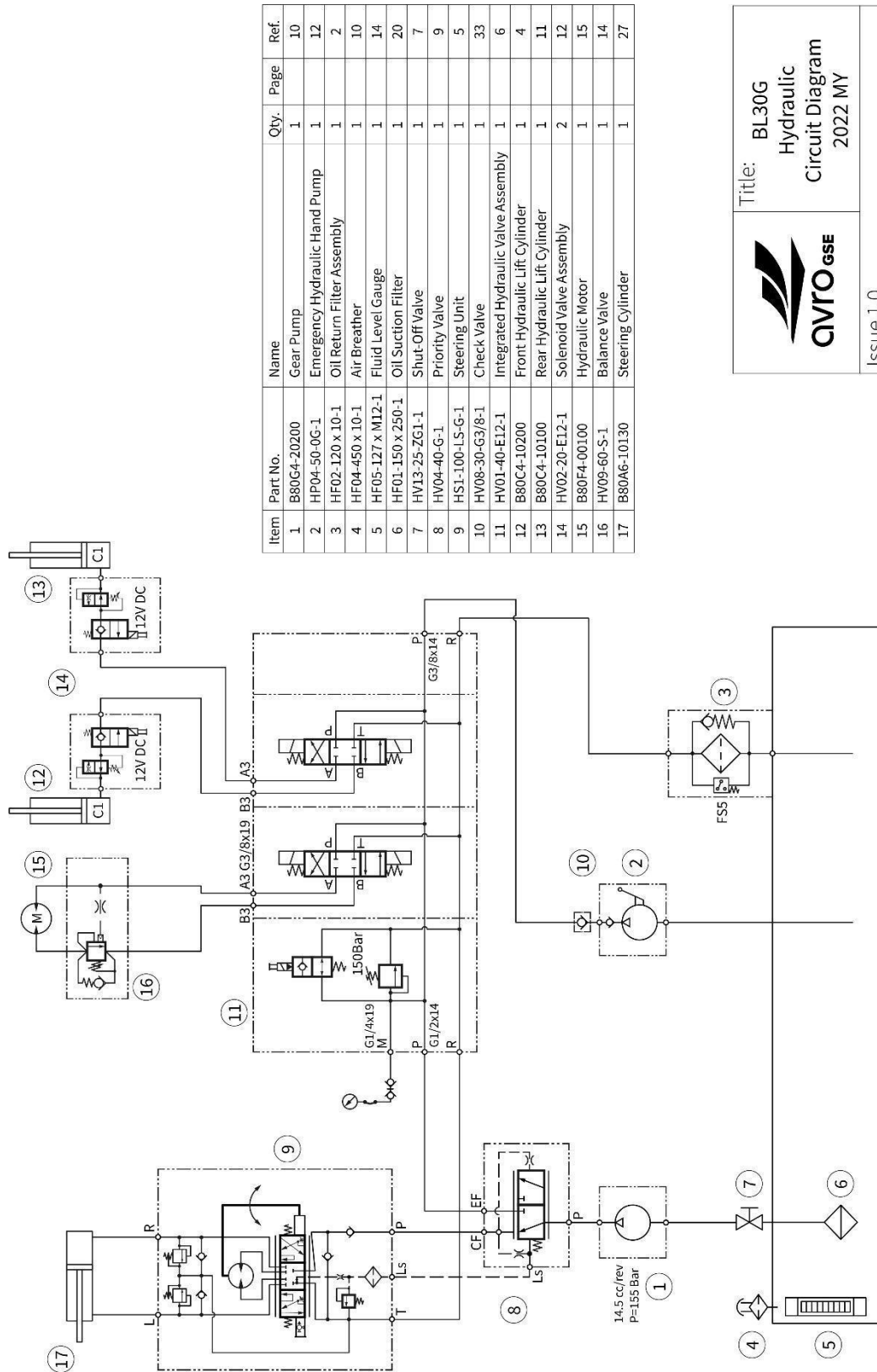

Item	Part No.	Name	Qty.	Page	Ref.
1	B80C4-20200	Gear Pump	1	10	10
2	HP04-50-0G-1	Emergency Hydraulic Hand Pump	1	12	12
3	HF02-120 x 10-1	Oil Return Filter Assembly	1	2	2
4	HF04-450 x 10-1	Air Breather	1	10	10
5	HF05-127 x M12-1	Fluid Level Gauge	1	14	14
6	HF01-150 x 250-1	Oil Suction Filter	1	20	20
7	HV13-25-ZG1-1	Shut-Off Valve	1	7	7
8	HV04-40-G-1	Priority Valve	1	9	9
9	HS1-100-LS-G-1	Steering Unit	1	5	5
10	HV08-30-G3/8-1	Check Valve	1	33	33
11	HV01-40-E12-1	Integrated Hydraulic Valve Assembly	1	6	6
12	B80C4-10200	Front Hydraulic Lift Cylinder	1	4	4
13	B80C4-10100	Rear Hydraulic Lift Cylinder	1	11	11
14	HV02-20-E12-1	Solenoid Valve Assembly	2	12	12
15	B80F4-00100	Hydraulic Motor	1	15	15
16	HV09-60-S-1	Balance Valve	1	14	14
17	B80A6-10130	Steering Cylinder	1	27	27



Title: BL30G
Hydraulic
Circuit Diagram
2022 MY

ISSUE 1.0

PAGE INTENTIONALLY LEFT BLANK

EXPLODED PARTS VIEWS & PARTS LISTS

SEATS

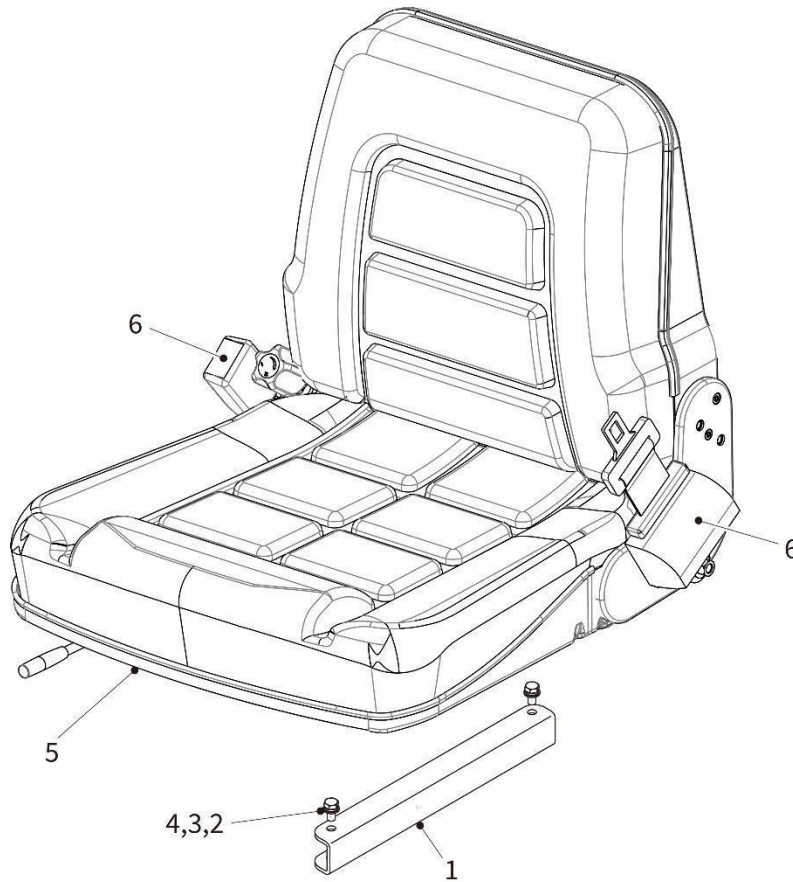

Seat Installation - Exploded Parts View

Seat Installation – Spare Parts List

Item	Part No.	Description	Qty	Remarks
1	PRPW02835	Seat Mounting	2	
2	PRFA00061	Bolt, M8 x 16mm	4	
3	PRFA00009	Washer, Flat, M8	4	
4	PRFA00010	Washer, Lock, M8	4	
5	PRPW00054	Seat Assembly	1	
6	PRPW00036	Seat Belt w/switch (Orange)	1	

BELT FRAME ASSEMBLY

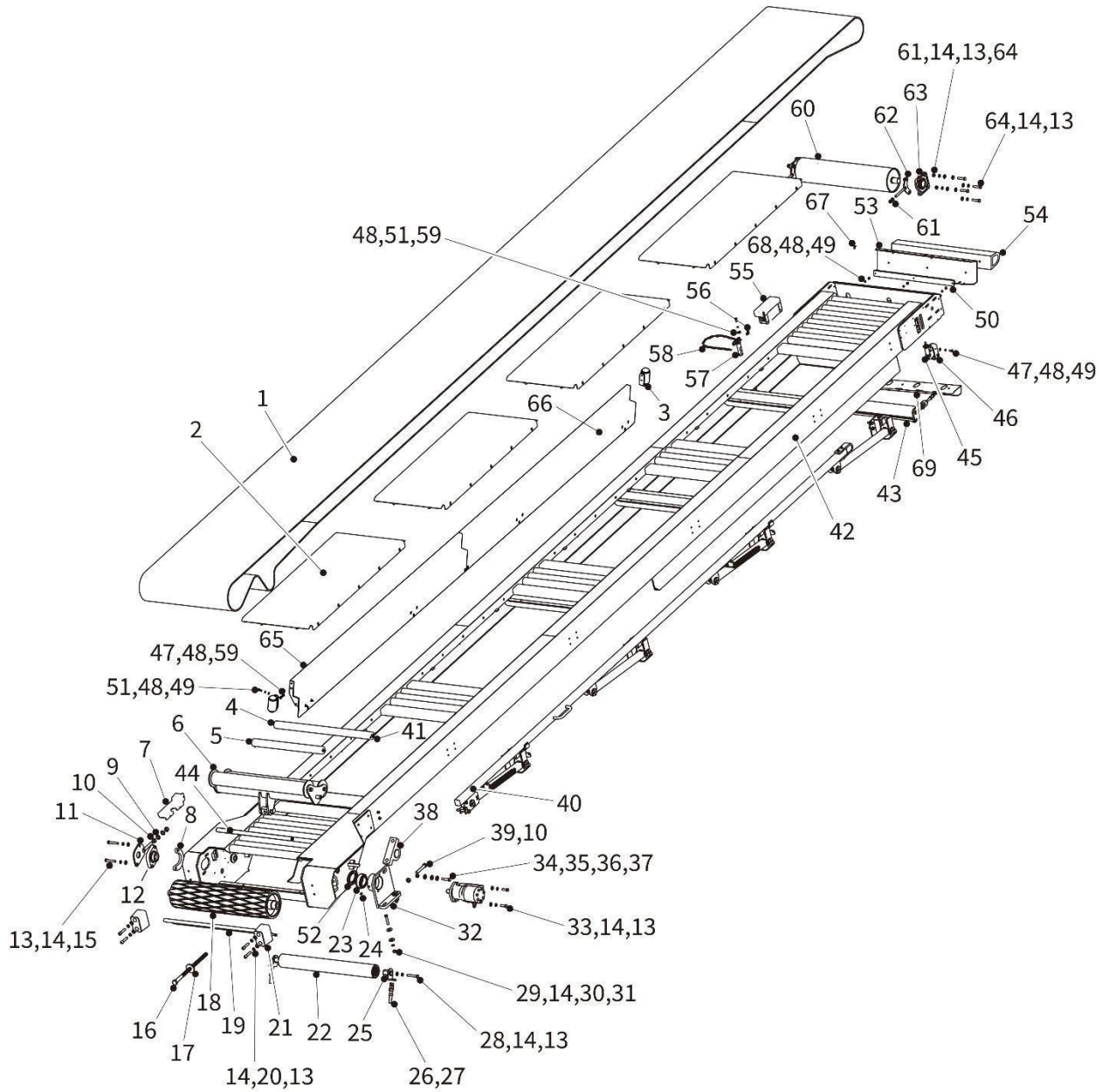

Belt Frame Assembly - Exploded Parts View

Belt Frame Assembly – Spare Parts List

Item	Part No.	Description	Qty	Remarks
1	PRPW02705	Conveyor Belt	1	
2	PRPW03100	Support Plate	4	
3	PRPW03101	Guide Wheel Assembly	2	
4	PRPW03102	Idler, Long	5	
5	PRPW03103	Idler, Short	27	
6	PRPW03104	Tightening Support Assembly	1	
7	PRPW03105	Protective Plate	1	
8	PRPW03106	Threaded Plate	1	
9	PRFA00068	Washer, Flat, M16	2	
10	PRFA00073	Nut, M16	3	
11	PRPW03107	Adjusting Seat, Welded	1	
12	PRPW3108	Bearing Seat	1	
13	PRFA00030	Washer, Flat, M12	22	
14	PRFA00034	Washer, Lock, M12	20	
15	PRFA00288	Bolt, M12 x 70 mm	2	
16	PRFA00289	Bolt, M20 x 380 mm, threaded length 300 mm	1	
17	PRPW03109	Shim	1	
18	PRPW03110	Rear Drive Drum	1	
19	PRPW03111	Rear Baffle	1	
20	PRFA00290	Screw, Hex Socket Head Cap, M12 x 55 mm	4	
21	PRPW03112	Bumper Block, Black	2	
22	PRPW03113	Roller	1	
23	PRPW03114	Tapered Roller Bearing	1	
24	PRPW03115	Grease Nipple, M10 x 1	1	
25	PRPW03116	Pull Plate	2	
26	PRFA00291	Nut, M16 x 1.5	6	
27	PRFA00292	Bolt, M16 x 1.5 x 120 mm	2	
28	PRFA00238	Bolt, M12 x 75 mm	2	
29	PRFA00294	Nut, M12	2	
30	PRFA00030	Washer, Flat, M12	4	

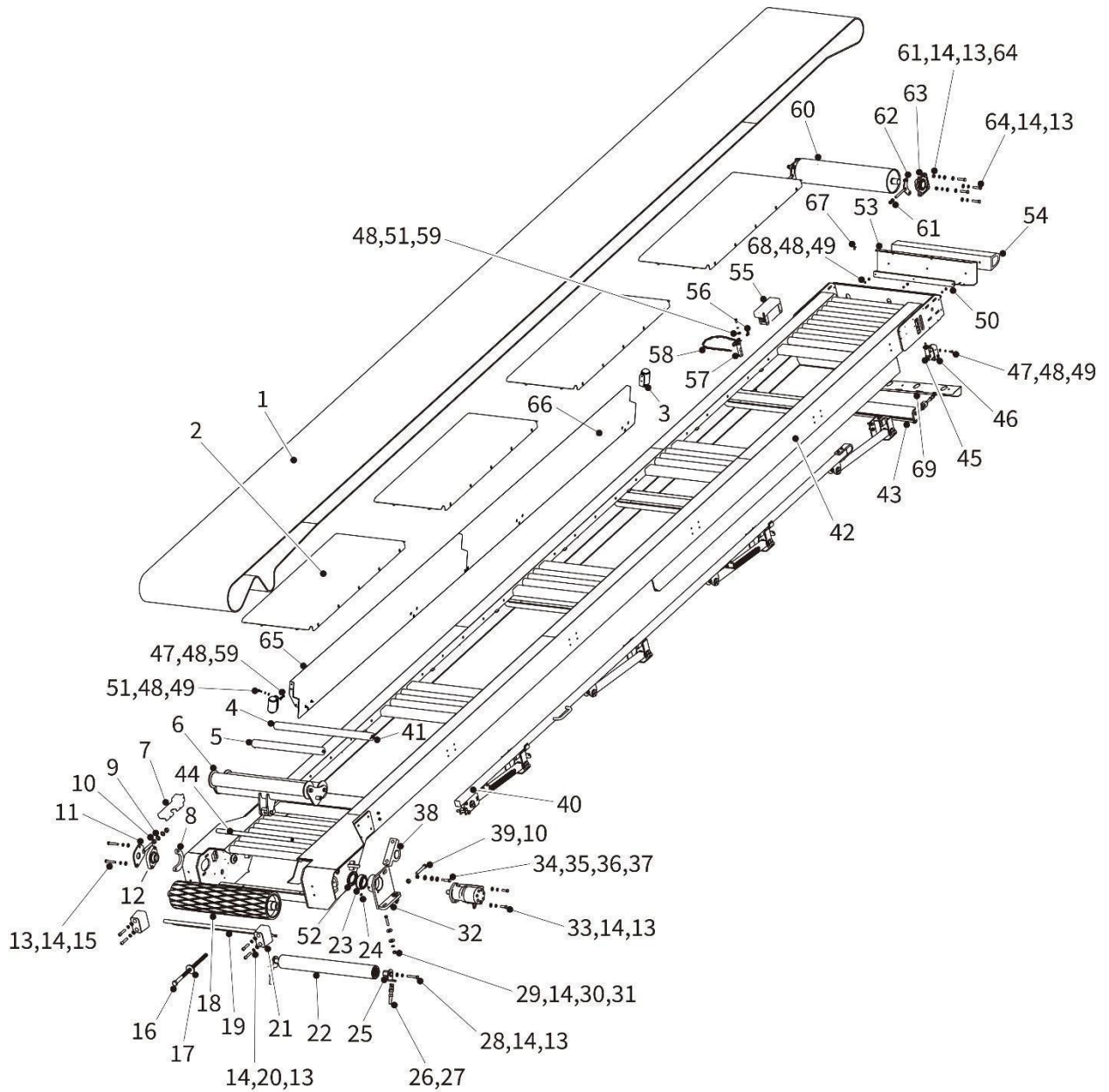

Belt Frame Assembly - Exploded Parts View

Belt Frame Assembly – Spare Parts List

Item	Part No.	Description	Qty	Remarks
31	PRFA00295	Bolt, M12 x 60 mm	2	
32	PRPW03117	Motor Support Bracket	1	
33	PRFA00042	Bolt, M12 x 35 mm	2	
34	PRFA00296	Bolt, Special	1	
35	PRFA00072	Washer, Flat, M14	1	
36	PRFA00151	Washer, Nylon, Special	2	
37	PRFA00297	Nut, Self-locking, M12	1	
38	PRPW03118	Bearing Pedestal Assembly	2	
39	PRFA00298	Bolt, M16 x 95 mm	1	
40	PRPW03125	Handrail Assembly, Complete	1	
41	PRFA00299	Pin, Split Cotter, 5 x 50 mm	6	
42	PRPW03119	Belt Frame	1	
43	PRPW03124	Front Roller Adjustment Assembly	1	
44	PRPW03120	Round Bar, Steel	1	
45	PRPW03121	Vertical Idler	4	
46	PRPW03122	Mounting Plate, Vertical Idler	4	
47	PRFA00300	Bolt, M8 x 16 mm	20	
48	PRFA00010	Washer, Lock, M8	28	
49	PRFA00009	Washer, Flat, M8	15	
50	PRPW03123	Mounting Bracket	1	
51	PRFA00033	Bolt, M8 x 20 mm	5	
52	PRPW03126	Skeleton Oil Seal, Type TC, i.d. 60 mm, o.d. 90 mm, thickness 10 mm	1	
53	PRPW03127	Mounting Plate	1	
54	PRPW03128	Protective Bumper, Rubber	1	
55	PRPW03129	Guard, Protective, Switch Box	1	
56	PRFA00004	P-clip, M10	2	
57	PRFA00311	Pin	1	
58	PRPW03130	Left Rear Baffle	1	
59	PRFA00009	Washer, Flat, M8	13	
60	PRPW03131	Front Drive Drum	1	

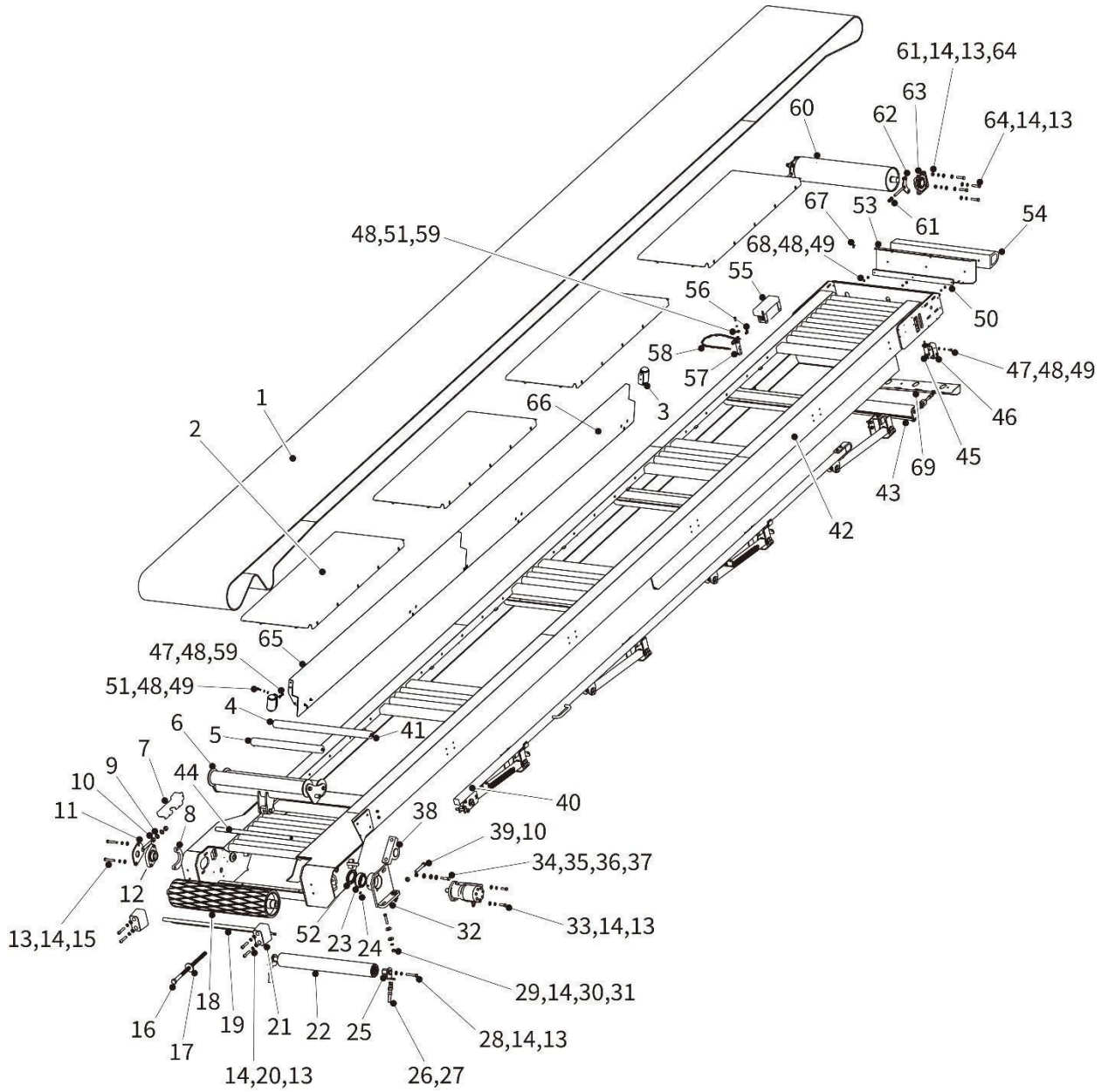

Belt Frame Assembly - Exploded Parts View

Belt Frame Assembly – Spare Parts List

Item	Part No.	Description	Qty	Remarks
61	PRFA00294	Nut, M12	8	
62	PRPW03132	Support Plate, Welded	2	
63	PRPW03133	Bearing Pedestal	2	
64	PRFA00301	Bolt, M12 x 50 mm	8	
65	PRPW03134	Left Rear Luggage Rail	1	
66	PRPW03135	Left Front Luggage Rail	1	
67	PRFA00312	Screw, Hex Socket Countersunk Head, M8 x 16 mm	3	
68	PRFA00047	Bolt, M8 x 35 mm	3	
69	PRPW03136	Sensor Bracket	1	

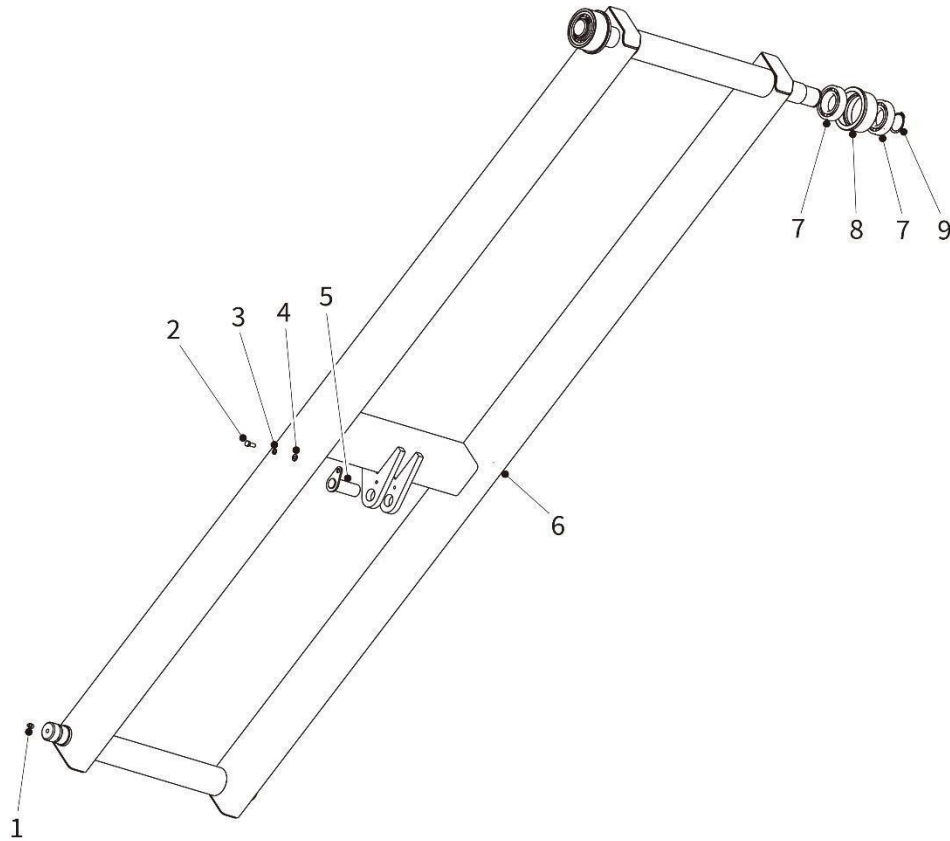

Front Lifting Frame - Exploded Parts View

Front Lifting Frame – Spare Parts List

Item	Part No.	Description	Qty	Remarks
1	PRPW02836	Grease Nipple	2	
2	PRFA00033	Bolt, M8 x 20 mm	1	
3	PRFA00010	Washer, Lock, M8	1	
4	PRFA00009	Washer, Flat, M8	1	
5	PRPW02532	Pin, Flanged Head	1	
6	PRPW02531	Rear Lifting Frame	1	
7	PRPW02534	Single Row deep groove Bearing with integral seals, Type 6209-2Z, i.d. 45 mm, o.d. 85 mm, total width 19 mm, chamfers 1.1 mm (min.)	4	
8	PRPW02533	Bearing Sheath	2	
9	PRPW02837	Circlip, M5	2	

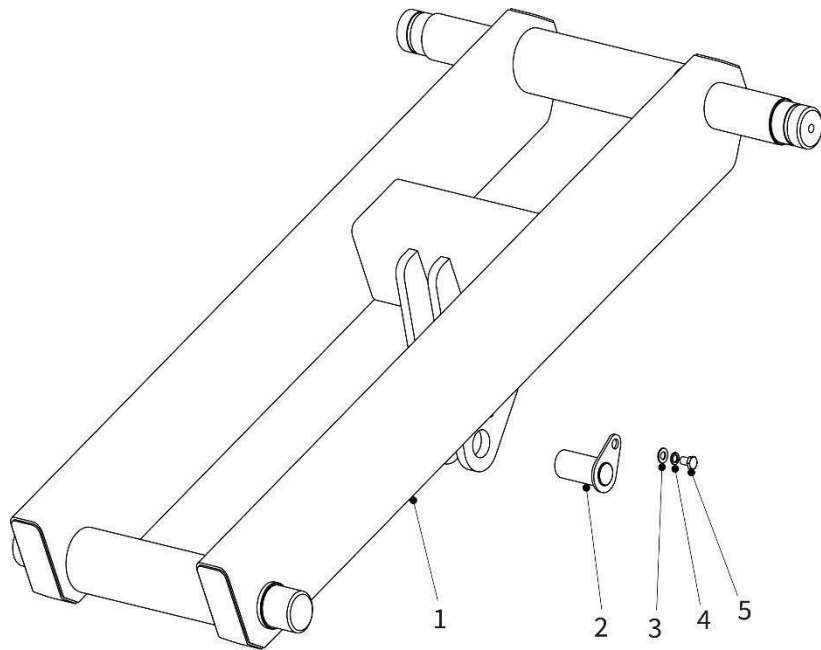

Rear Lifting Frame - Exploded Parts View

Rear Lifting Frame – Spare Parts List

Item	Part No.	Description	Qty	Remarks
1	PRPW02535	Rear Lifting Frame	1	
2	PRPW02532	Pin, Flanged Head	1	
3	PRFA00033	Bolt, M8 x 20 mm	1	
4	PRFA00010	Washer, Lock, M8	1	
5	PRFA00009	Washer, Flat, M8	1	

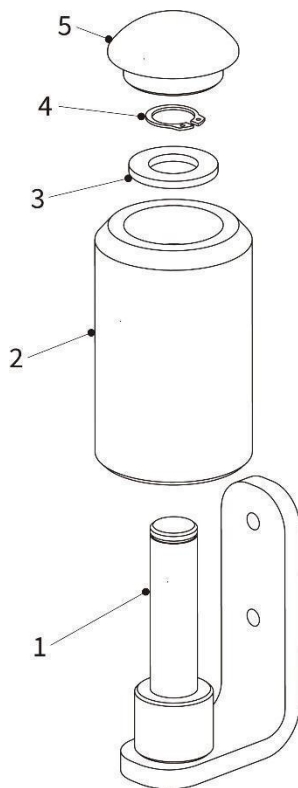

Guide Wheel Assembly - Exploded Parts View

Guide Wheel Assembly - Spare Parts List

Item	Part No.	Description	Qty	Remarks
1	PRPW03137	Support Assembly	1	
2	PRPW03138	Guide Wheel, Nylon	1	
3	PRFA00112	Washer, Flat, M18	1	
4	PRPW03139	Circlip, M18		
5	PRPW03154	Blanking Cap	1	

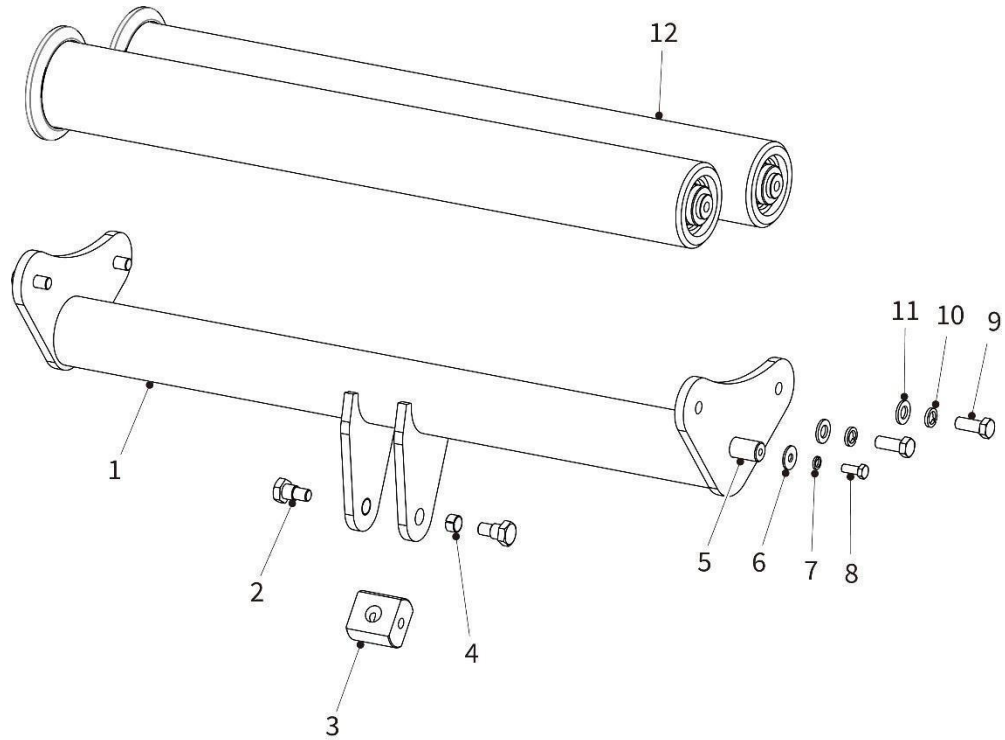

Tightening Support Assembly - Exploded Parts View

Tightening Support Assembly – Spare Parts List

Item	Part No.	Description	Qty	Remarks
1	PRPW03140	Tensioner Support	1	
2	PRFA00302	Bolt, Special	2	
3	PRFA00303	Nut, Special	1	
4	PRPW03141	Bushing, Type SF-1-1510, self-lubricating, oilless, composite, i.d. 15 mm, o.d. 17 mm, length 10 mm, wall thickness 1.01mm	2	
5	PRPW03142	Tandem Shaft	1	
6	PRFA00009	Washer, Flat, M8	2	
7	PRFA00010	Washer, Lock, M8	2	
8	PRFA00033	Bolt, M8 x 20 mm	2	
9	PRFA00138	Bolt, M12 x 30 mm	4	
10	PRFA00034	Washer, Lock, M12	4	
11	PRFA00030	Washer, Flat, M12	4	
12	PRPW03143	Adjusting Roller	2	

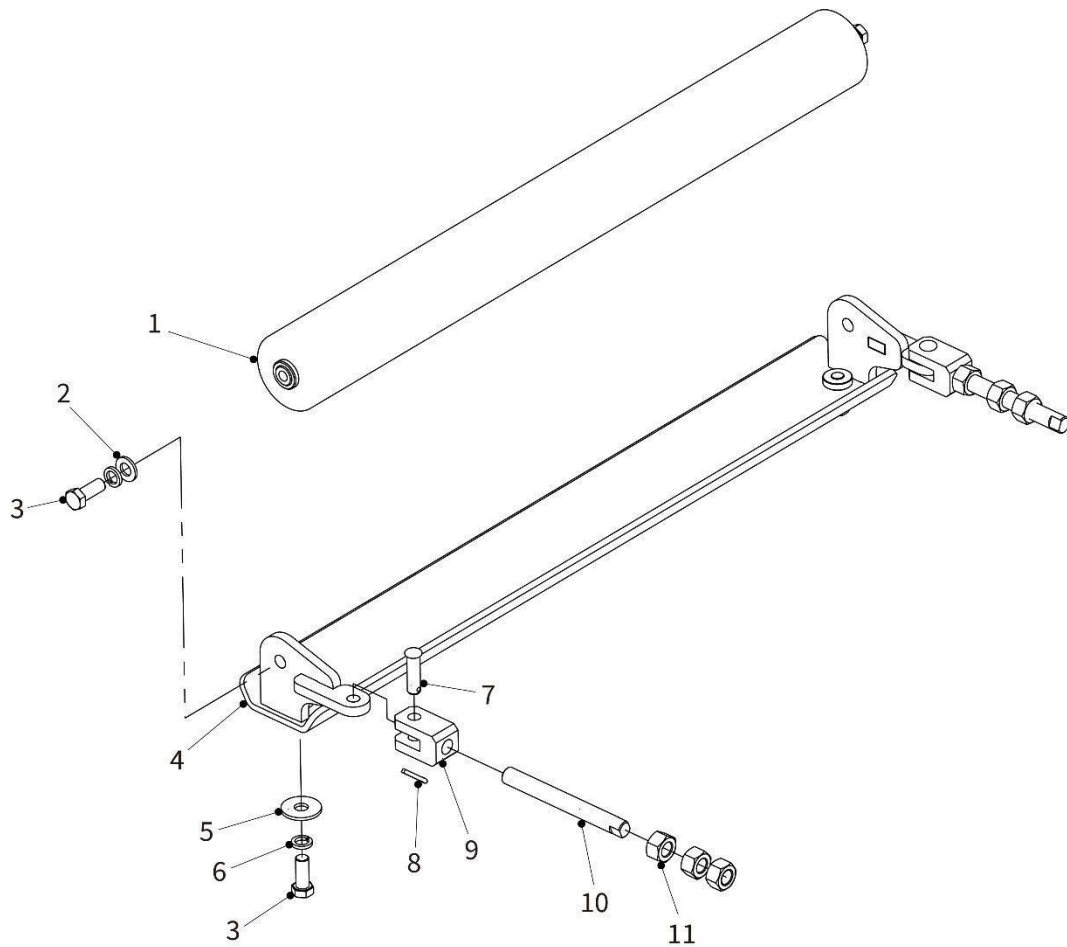

Front Roller Adjustment Assembly - Exploded Parts View

Front Roller Adjustment Assembly – Spare Parts List

Item	Part No.	Description	Qty	Remarks
1	PRPW03144	Roller	1	
2	PRFA00030	Washer, Flat, M12	2	
3	PRFA00183	Bolt, M12 x 30 mm	4	
4	PRPW03145	Adjustment Mechanism	1	
5	PRFA00030	Washer, Flat, M12	2	
6	PRFA00034	Washer, Lock, M12	4	
7	PRFA00304	Pin, Clevis, headed, with hole, 12 x 40 mm	2	
8	PRFA00306	Pin, Split Cotter, 4 x 182 mm	2	
9	PRPW03146	Pull Rod Head	2	
10	PRFA00305	Screw, Special, M16 x 1.5 mm	2	
11	PRFA00073	Nut, M16	6	

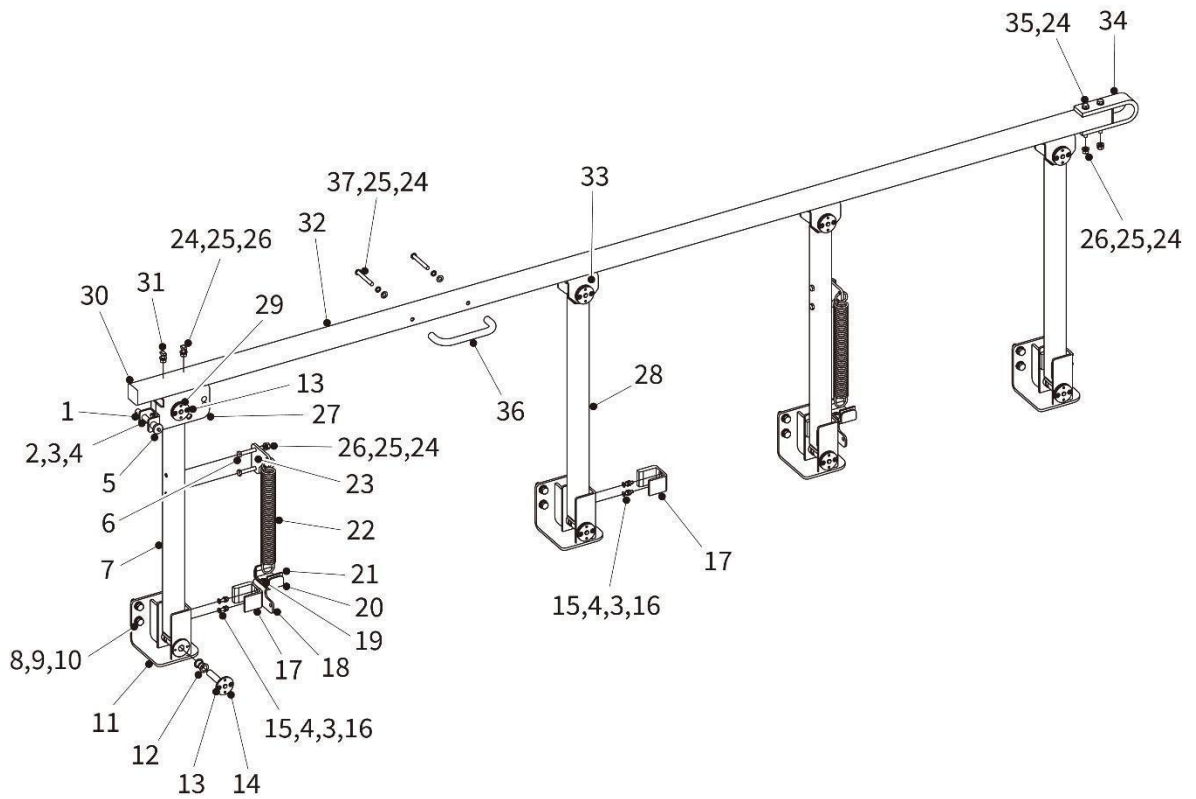

Handrail Assembly - Exploded Parts View

Handrail Assembly – Spare Parts List

Item	Part No.	Description	Qty	Remarks
1	PRPW03147	Bracket, Pin Stowage	1	
2	PRFA00108	Bolt, M6 x 16 mm	2	
3	PRFA00007	Washer, Lock, M6	10	
4	PRFA00006	Washer, Flat, M6	10	
5	PRPW02605	Pin, Handrail, Safety Lock	1	
6	PRFA00286	Bolt, M8 x 60 mm	4	
7	PRPW03148	Column, Handrail, Spring Mounting	2	
8	PRFA00008	Bolt, M10 x 30 mm	16	
9	PRFA00012	Washer, Lock, M10	16	
10	PRFA00011	Washer, Flat, M10	16	
11	PRPW03149	Handrail Mounting Base	4	
12	PRPW03150	Bearing, Plastic, Self-lubricating	16	
13	PRFA00308	Screw, Countersunk, Flat Head, Cross Recess, Type Z, M5 x 10 mm	16	
14	PRPW03151	Shaft Pin, Shouldered, Fixed, Column Base	4	
15	PRFA00307	Screw, Hex Socket Countersunk Head, M6 x 25 mm	8	
16	PRFA00025	Nut, M6	8	
17	PRPW03152	Block, Nylon	6	
18	PRPW03153	Limit Bracket	2	
19	PRFA00313	Screw, Hex Socket Countersunk Head, M6 x 12 mm	4	
20	PRPW03155	Holder, Nylon	2	
21	PRPW03156	Block, Nylon	2	
22	PRPW03157	Spring	2	
23	PRPW03158	Pull Plate	2	
24	PRFA00009	Washer, Flat, M8	18	
25	PRFA00010	Washer, Lock, M8	16	
26	PRFA00021	Nut, M8	14	
27	PRPW03159	Bracket, Handrail, Locking/Safety	1	
28	PRPW03160	Column, Handrail	2	
29	PRPW03161	Shaft Pin, Shouldered, Fixed, Column Top	4	
30	PRPW03162	End Face Cover Plate	2	

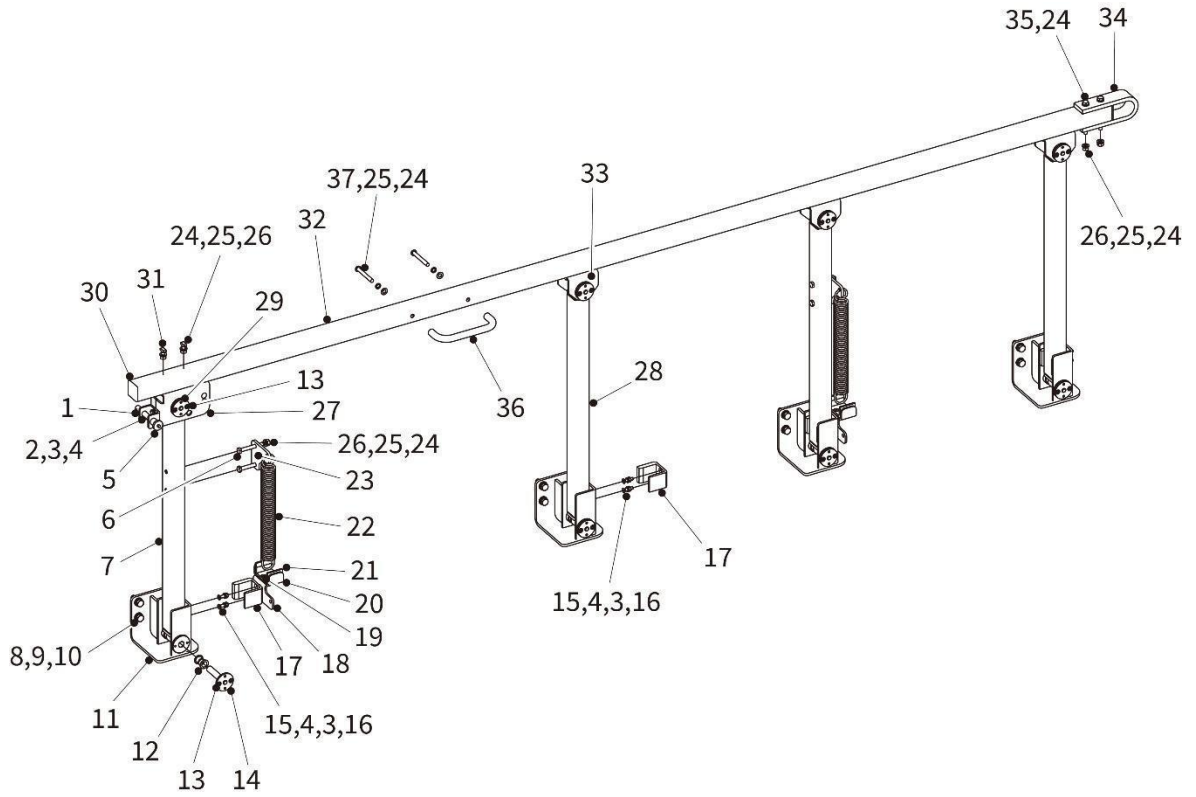

Handrail Assembly - Exploded Parts View

Handrail Assembly – Spare Parts List

Item	Part No.	Description	Qty	Remarks
31	PRFA00309	Bolt, Special, M8 x 20 mm	8	
32	PRPW02498	Handrail	1	
33	PRPW03163	Bracket, Handrail	3	
34	PRPW03164	Collision Protection Strip	1	
35	PRFA00310	Bolt, M8 x 80 mm, threaded length 25 mm	2	
36	PRPW03240	Handle	1	
37	PRFA00039	Screw, Flat Round Hex Socket Head, M8 x 20 mm	2	

BODY & EXTERIOR

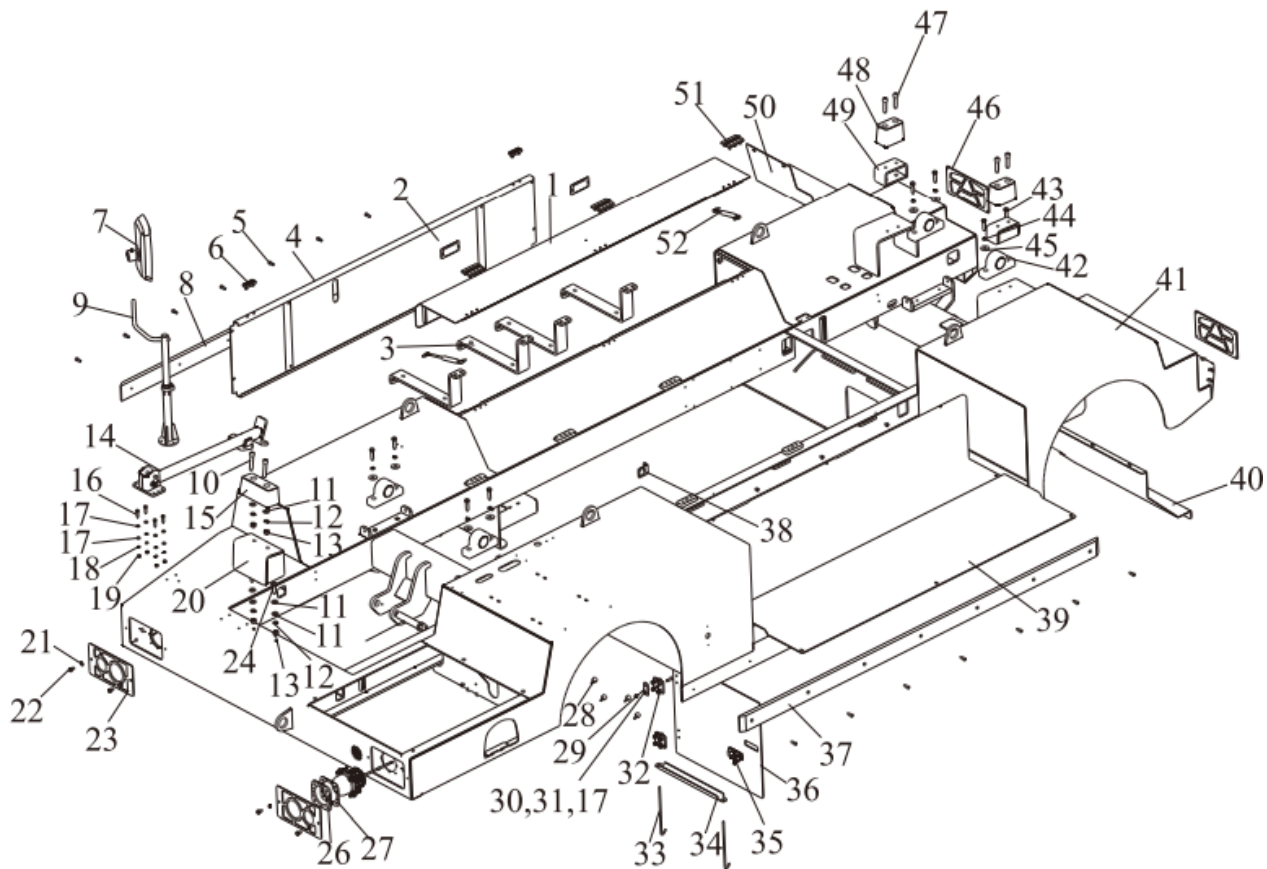

Vehicle Body - Exploded Parts View

Vehicle Body – Spare Parts List

Item	Part No.	Description	Qty	Remarks
1	PRPW02823	Upper Right Cover Assembly	1	
2	PRPW02824	Handle Assembly	2	
3	PRPW02807	Fuel Tank Bracket	4	
4	PRPW02808	Right Side Plate Assembly	1	
5	PRFA00022	Screw, M8 x 20 mm	14	
6	PRPW01668	Cushion	2	
7	PRPW03241	Rear-View Mirror	1	
8	PRPW02578	Side Collision Block, R.H.	1	
9	PRPW02530	Support Assembly	1	
10	PRFA00235	Screw, M14 x 70 mm	2	
11	PRFA00072	Washer, Flat, M14	6	
12	PRFA00118	Washer, Lock, 14	4	
13	PRFA00234	Nut, M14	4	
14	PRPW02565	Support Rod Assembly	1	
15	PRPW00502	Limit Block	1	
16	PRFA00253	Bolt, M8 x 30 mm	4	
17	PRFA00009	Washer, Flat, M8	16	
18	PRFA00010	Washer, Lock, 8	4	
19	PRFA00021	Nut, M8	4	
20	PRPW02809	Front Buffer Support	1	
21	PRFA00012	Washer, Lock, 10	4	
22	PRFA00055	Bolt, M10 x 16 mm	4	
23	PRPW02810	Protective Grill, Front Lights	2	
24	PRFA00122	Bolt, M14 x 40 mm	2	
25	PRPW02813	Pin	2	
26	PRPW02812	Headlamp Holder	2	
27	PRPW02811	Headlamp Gasket	2	
28		Cushion	4	D22A1-10004
29		Fire Plate Cushion Plate	2	B80D1-10013
30	PRFA00022	Screw, M8 x 20 mm	8	

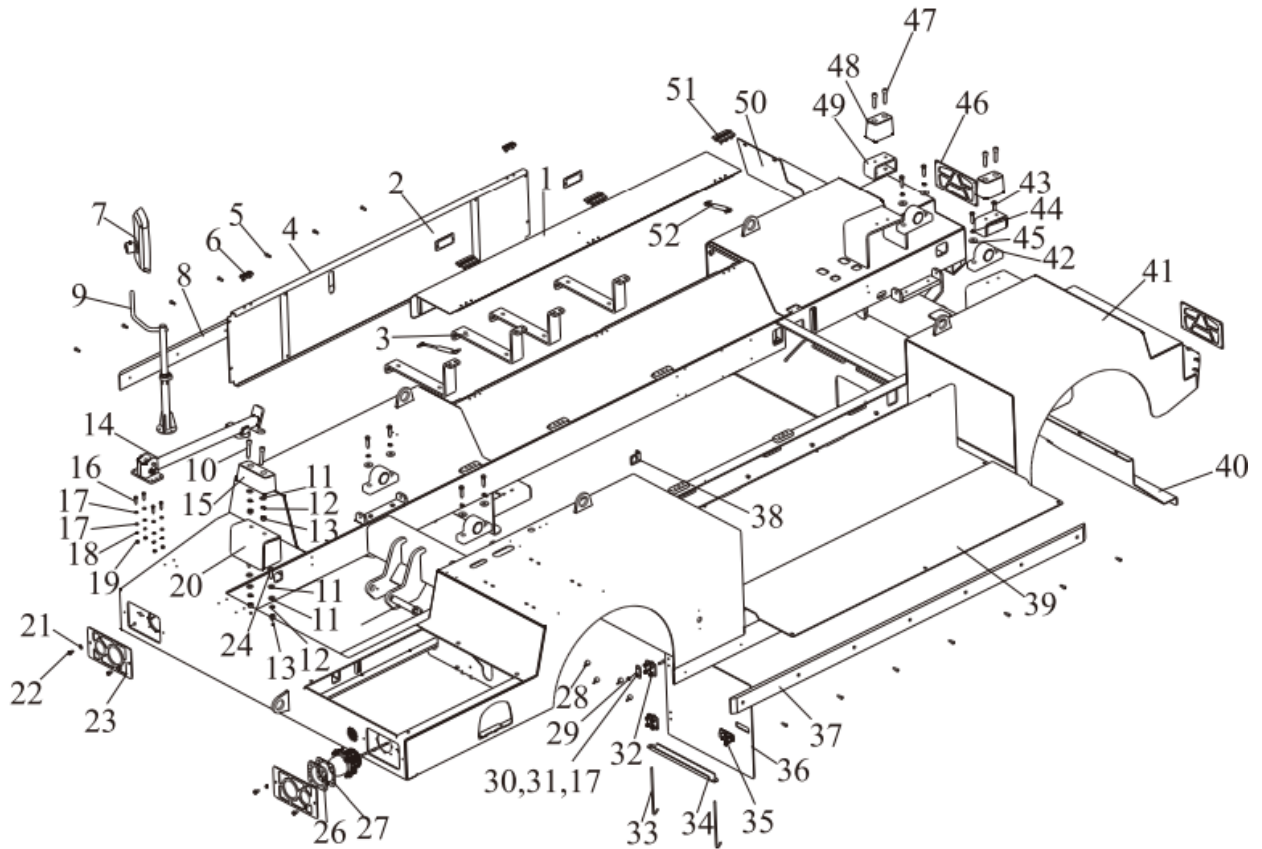

Vehicle Body - Exploded Parts View

Vehicle Body – Spare Parts List

Item	Part No.	Description	Qty	Remarks
31	PRFA00186	Nut, Self-locking, M8	8	
32		Hinge, CL226-1B	2	B80D1-10014
33		Hook Bolts	2	F60K1-10008
34		Battery Platen	1	B80J1-10004
35	PRPW00059	Battery Storage Lock	1	
36		Battery Bin Overturned	1	B80J1-10002
37	PRPW00578	Rub rail, plastic	1	B80D1-10002
38		Diagnosis Mouth	1	B80J1-10005
39	PRPW02815	Crew Compartment Floor	1	
40		Left Rear Fender	1	B80Z1-10006
41		Frame Body	1	B80J1-11000
42	PRPW03118	Bearing Seat Assembly	4	
43	PRFA00057	Bolt, M12 x 45 mm	8	
44	PRFA00034	Washer, Lock, 12	8	
45	PRFA00030	Washer, 12	8	
46	PRPW02818	Protective Grill, Rear Lights	2	
47	PRFA00236	Screw, M14 x 55 mm	4	
48		Limit Block	2	T160A1-10007
49		Rear Damping Pad	2	B80J1-10100
50	PRPW02819	Right Rear Fender	1	
51	PRPW02822	Hinge	3	
52	PRPW02820	Gas Spring	2	

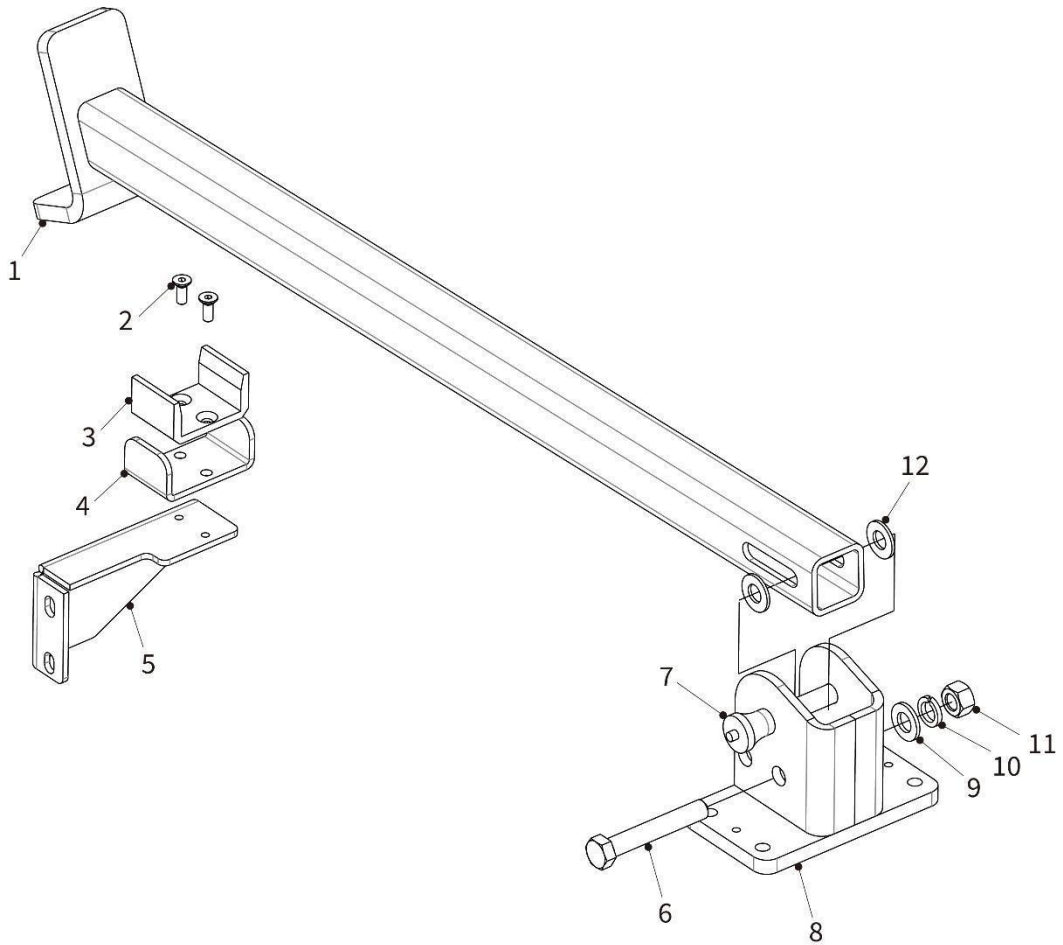

Safety Prop Assembly - Exploded Parts View

Safety Prop Assembly – Spare Parts List

Item	Part No.	Description	Qty	Remarks
1	PRPW02825	Safety Prop	1	
2	PRFA00237	Screw, Hex Socket Countersunk Head, M6 x16 mm	2	
3	PRPW02826	Nylon Insert, for Safety Prop Stowage Clip	1	
4	PRPW02829	Stowage Clip, Nylon, for Safety Prop	1	
5	PRPW02830	Stowage Bracket, Support Bar	1	
6	PRFA00238	Bolt, M12 x 75 mm	1	
7	PRPW02605	Handrail Pin w/ Chain	1	
8	PRPW2831	Safety Prop Base	1	
9	PRFA00030	Washer, Flat, M12	1	
10	PRFA00034	Washer, Lock, M12	1	
11	PRFA00239	Nut, M12	1	
12	PRFA00240	Washer, Special	2	

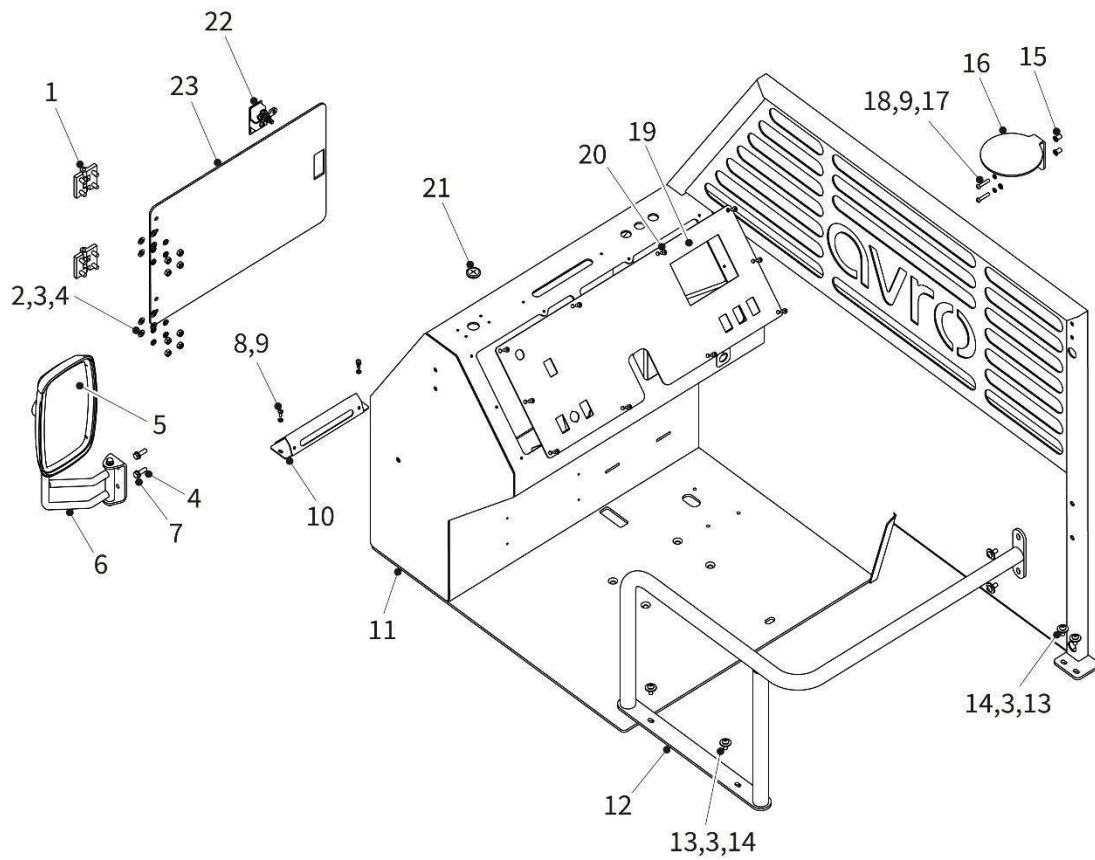

Drivers Compartment - Exploded Parts View

Drivers Compartment – Spare Parts List

Item	Part No.	Description	Qty	Remarks
1	PRPW01778	Hinge	2	
2	PRFA00021	Nut, M8	16	
3	PRFA00010	Washer, Lock, M8	22	
4	PRFA00009	Washer, Flat, M8	18	
5	PRPW03241	Wing Mirror	1	
6	PRPW02832	Wing Mirror Bracket	1	
7	PRFA00013	Bolt, M8 x 25 mm	2	
8	PRFA00114	Screw, Cross Recessed Pan Head, M5 x 12 mm	3	
9	PRFA00007	Washer, Lock, M6	4	
10	PRPW02577	Dash Light Housing	1	
11	PRPW02562	Cab Assembly	1	
12	PRPW02833	Guardrail Assembly	1	
13	PRFA00009	Washer, Flat, M8	6	
14	PRFA00039	Screw, Flat Round Hex Socket Head, M8 x 20 mm	6	
15	PRFA00241	Nut, Special, M8	2	
16	PRPW02581	Warning Beacon Mount	1	
17	PRFA00242	Screw, Flat Round Hex Socket Head, M6 x 30 mm	2	
18	PRFA00006	Washer, Flat, M6	2	
19	PRPW02834	Instrument Panel	1	
20	PRFA00016	Screw, Flat Round Hex Socket Head, M6 x 12 mm	10	
21	PRPW00636	Grommet	3	
22	PRPW02756	Latch	1	
23	PRPW02759	Access Panel	1	

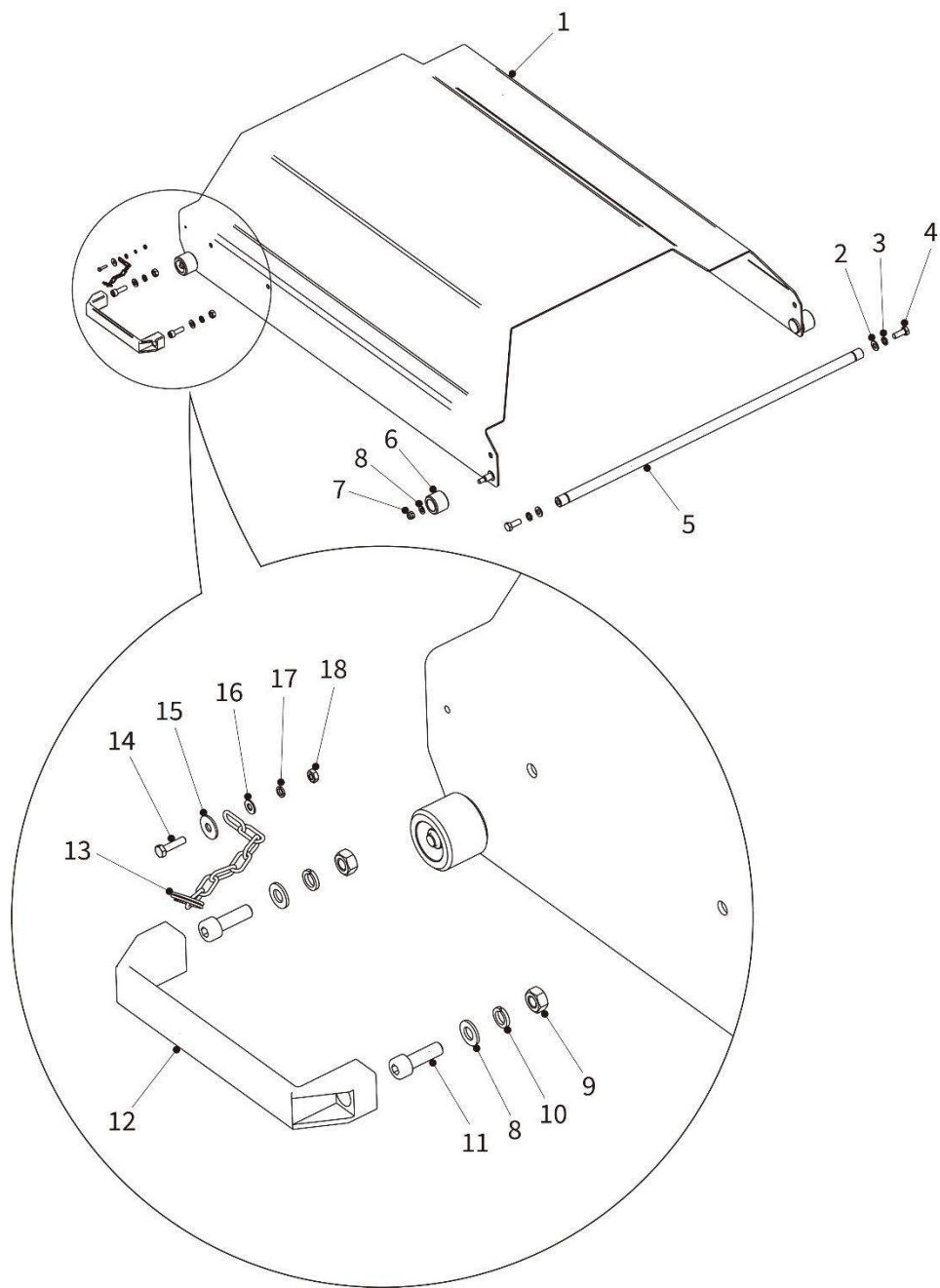

Engine Cover - Exploded Parts View

Engine Cover – Spare Parts List

BL30D Belt Loader

Item	Part No.	Description	Qty	Remarks
1	PRPW02838	Engine Cover Panel	1	
2	PRFA00011	Washer, Flat, M10	2	
3	PRFA00012	Washer, Lock, M10	2	
4	PRFA00063	Bolt, M10 x 25 mm	2	
5	PRPW02839	Strut Assembly	1	
6	PRPW02840	Guidewheel	4	
7	PRFA00186	Nut, Self-locking, M8	4	
8	PRFA00009	Washer, Flat, M8	6	
9	PRFA00021	Nut, M8	2	
10	PRFA00010	Washer, Lock, M8	2	
11	PRFA00017	Screw, Hex Socket Head Cap, M8 x 25 mm	2	
12	PRPW03243	Handle, Interior	1	
13	PRPW02841	Chain, $\phi 2$ x 150 mm	1	
14	PRFA00243	Bolt, M4 x 16 mm	1	
15	PRFA00244	Washer, Flat, M5	1	
16	PRFA00245	Washer, Flat, M4	1	
17	PRFA00246	Washer, Lock, M4	1	
18	PRFA00247	Nut, M4	1	

CONTROLS AND INSTRUMENTS

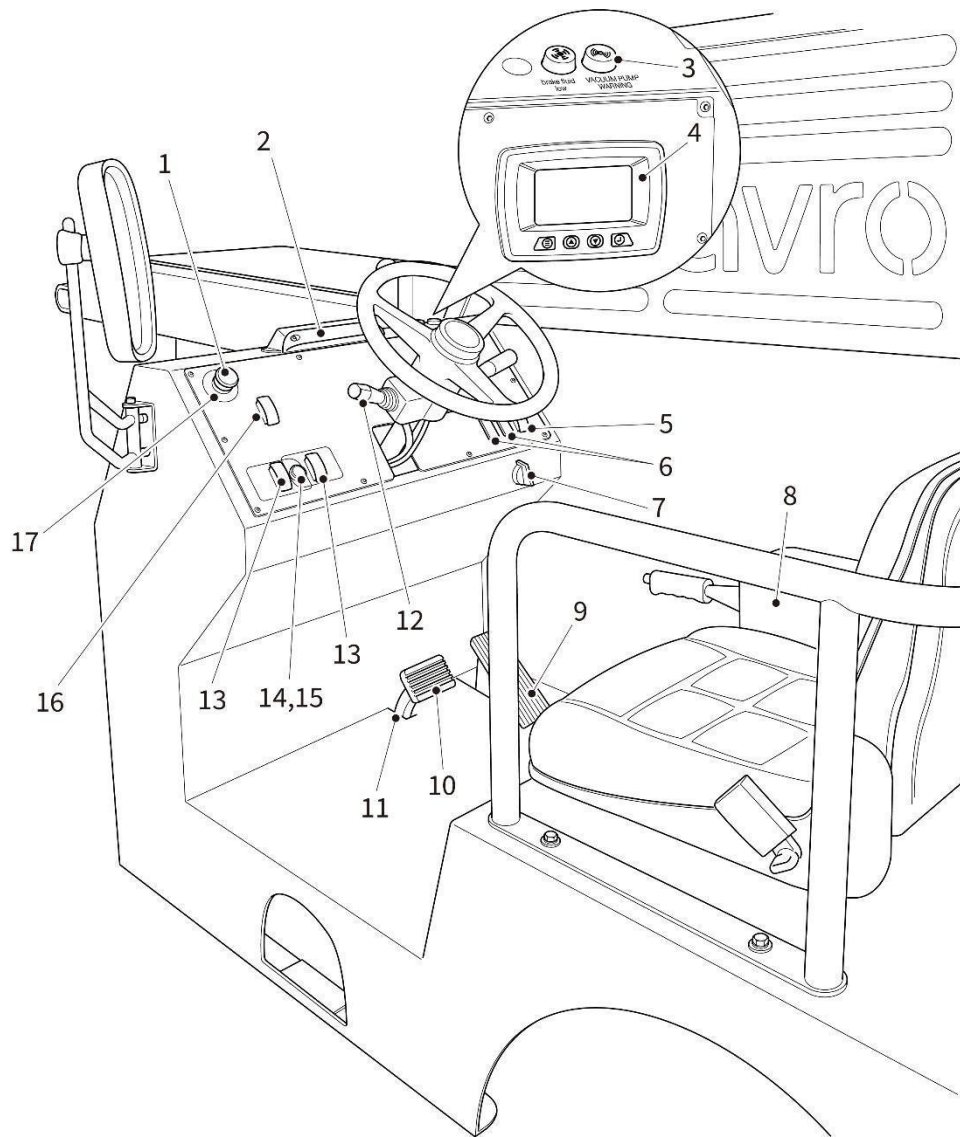

Controls and instruments - Exploded Parts View

Controls and instruments – Spare Parts List

Item	Part No.	Description	Qty	Remarks
1	PRPW00041	EMERGENCY STOP switch	1	
2	PRPW02843	Dashboard Light	1	
3	PRPW02844	Flash Buzzer	2	
4	PRPW00408	Dash Display Instrument, BL30D	1	
5	PRPW02846	Headlight Switch	1	
6	PRPW02847	Blanking Cover	2	
7	PRPW00051	Ignition Switch	1	
8	PRPW00676	Park Brake Switch	1	
9	PRPW00616	Accelerator Pedal	1	
10	N/A	Brake Pedal (Part of the Foot Brake Support Assembly)	-	
11	PRPW00405	Footbrake Switch (Attached to Brake Pedal Assembly)	1	
12	PRPW02403	Integrated Direction/Gear Shift/Turn Signal Control	1	
13	PRPW02849	Switch, Hydraulic Cylinder Control Valve	2	
14	PRPW00958	Connector, Interlock Button Switch	1	
15	PRPW00957	Lift Cylinder Interlock Switch, Momentary, Green	1	
16	PRPW00002	Drivers Throttle Switch	1	
17	PRPW00681	Label, Emergency Stop Switch	1	

PARKING BRAKE CONTROL

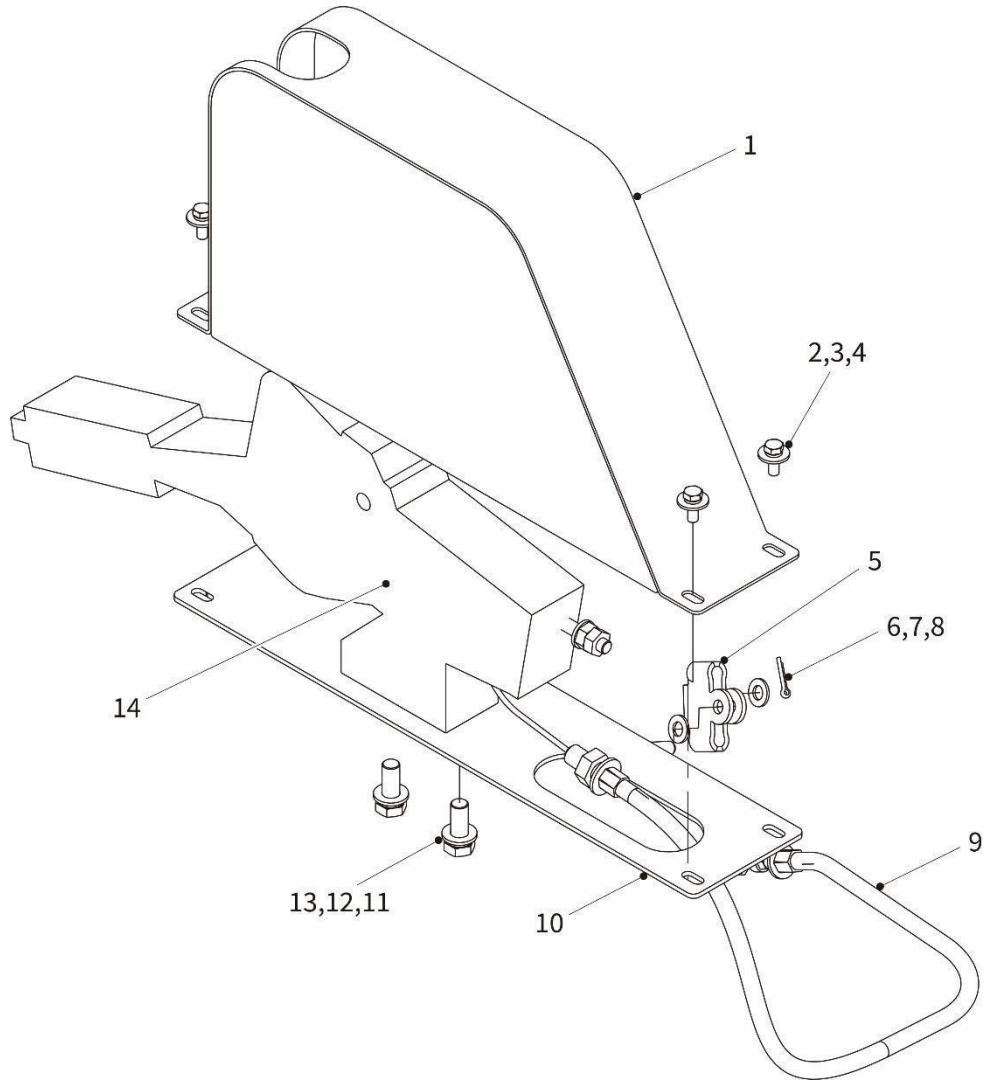

Parking Brake Mounting - Exploded Parts View

Parking Brake Mounting – Spare Parts List

Item	Part No.	Description	Qty	Remarks
1	PRPW02850	Cover Assembly	1	
2	PRFA00006	Washer, Flat, M6	4	
3	PRFA00007	Washer, Lock, M6	4	
4	PRFA00248	Bolt, M6 x 16 mm	4	
5	PRPW02584	Connection Bracket	1	
6	PRFA00264	Pin, Clevis, headed, with hole, 8 x 22 mm	1	
7	PRFA00009	Washer, Flat, M8	2	
8	PRFA00265	Pin, Split Cotter, 3.2 x 14 mm	1	
9	PRPW00011	Park Brake Cable	1	
10	PRPW02851	Mounting Plate	1	
11	PRFA00063	Bolt, M10 x 25mm	2	
12	PRFA00012	Washer, Lock, M10	2	
13	PRFA00011	Washer, Flat, M10	2	
14	PRPW02852	Park Brake Handle	1	

ELECTRICAL SYSTEM

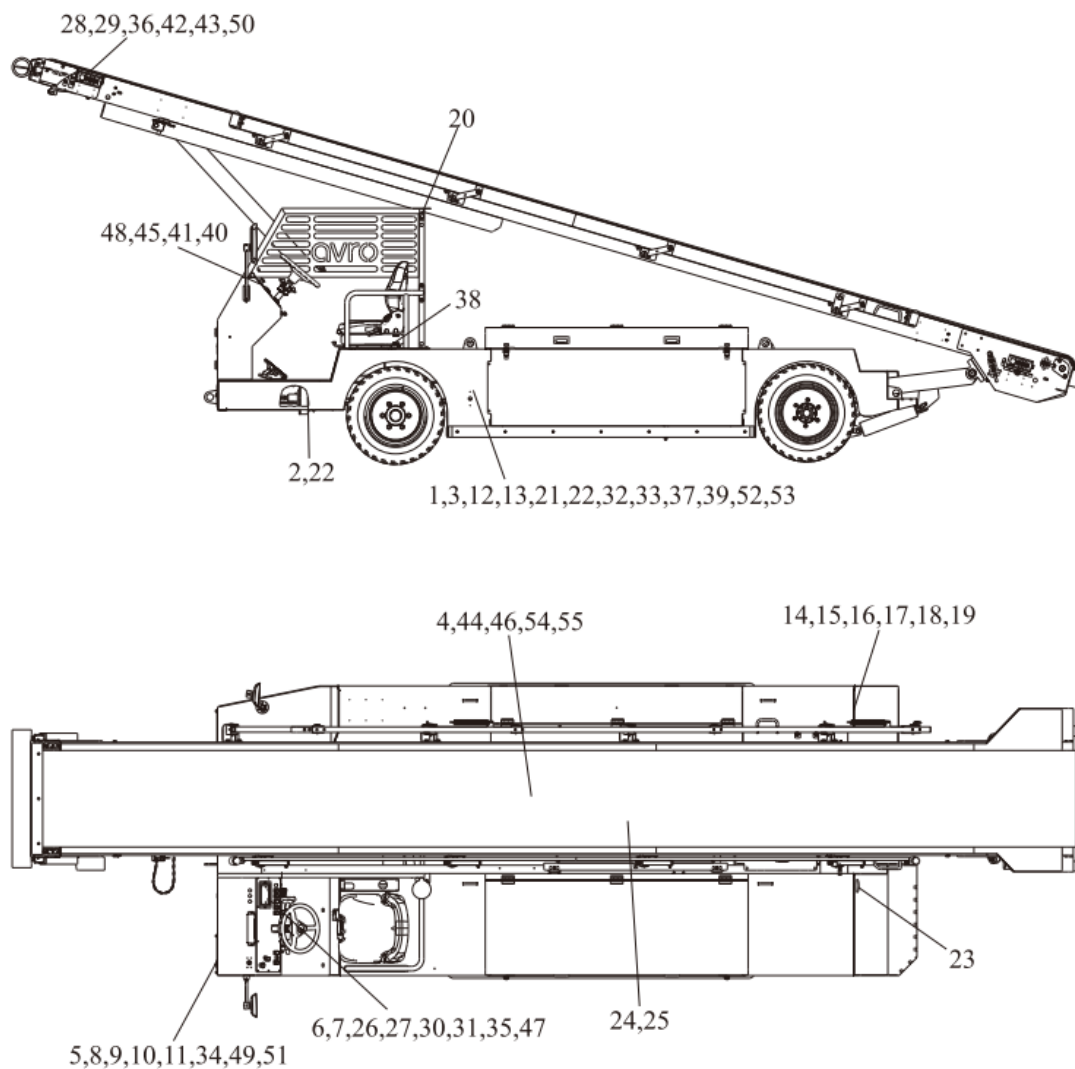

Electrical system - Exploded Parts View

Electrical System – Spare Parts List

Item	Part No.	Description	Qty	Remarks
1	PRPW02858	Battery	1	
2	PRPW00405	Foot Brake Switch	1	
3		Banding Belt	20	180
4		Fuse Box	1	A160G2-10200
5	PRPW02860	Dipped Headlight	2	
6		Instrument	1	T20J2-70200L
7		Combination Switch	1	B80D2-60300
8		Electric Horn	1	DT09G-DL124ED
9	PRFA00033	Bolt, M8 x 20 mm	1	
10	PRFA00009	Washer, Flat, M8	1	
11	PRFA00010	Washer, Lock, 8	1	
12		Central Control Box	1	T20L2-10100E(L)
13	PRFA00038	Screw, M6 x 20 mm	4	
14	PRPW02862	Three-Color Rear Taillights	2	
15	PRPW00694	Reversing Buzzer	1	
16	PRFA00001	Bolt, M6 x 20 mm	1	
17		Gasket, 6	2	GB/T 96.1
18	PRFA00007	Washer, Lock, 6	1	
19	PRFA00025	Nut, M6	1	
20	PRPW01155	Beacon	1	
21		Vehicle Wiring Harness	1	B80J2-80100
22	PRPW00136	Accelerator pedal	1	
23		Manual Accelerator Control	1	B80D2-50200
24	PRPW02868	Transmission Oil Temperature Sensor	1	
25	PRPW02340	Vehicle Speed Sensor	1	
26	PRPW00051	Keyless Ignition Switch	1	
27		Emergency Stop Switch	3	B80J2-60100
28	PRPW00021	Conveyor belt switch box w/strain relief	2	
29		Ultrasonic Sensors	2	B80D5-50400
30	PRPW02843	Dashboard Light	1	
31	PRPW00959	Lift Cylinder Actuator Switch, Momentary, Rocker	1	
32	PRPW02356	Control module, hydraulics	1	
33	PRPW02726	Control Module, Hydraulics	1	

PAGE INTENTIONALLY LEFT BLANK

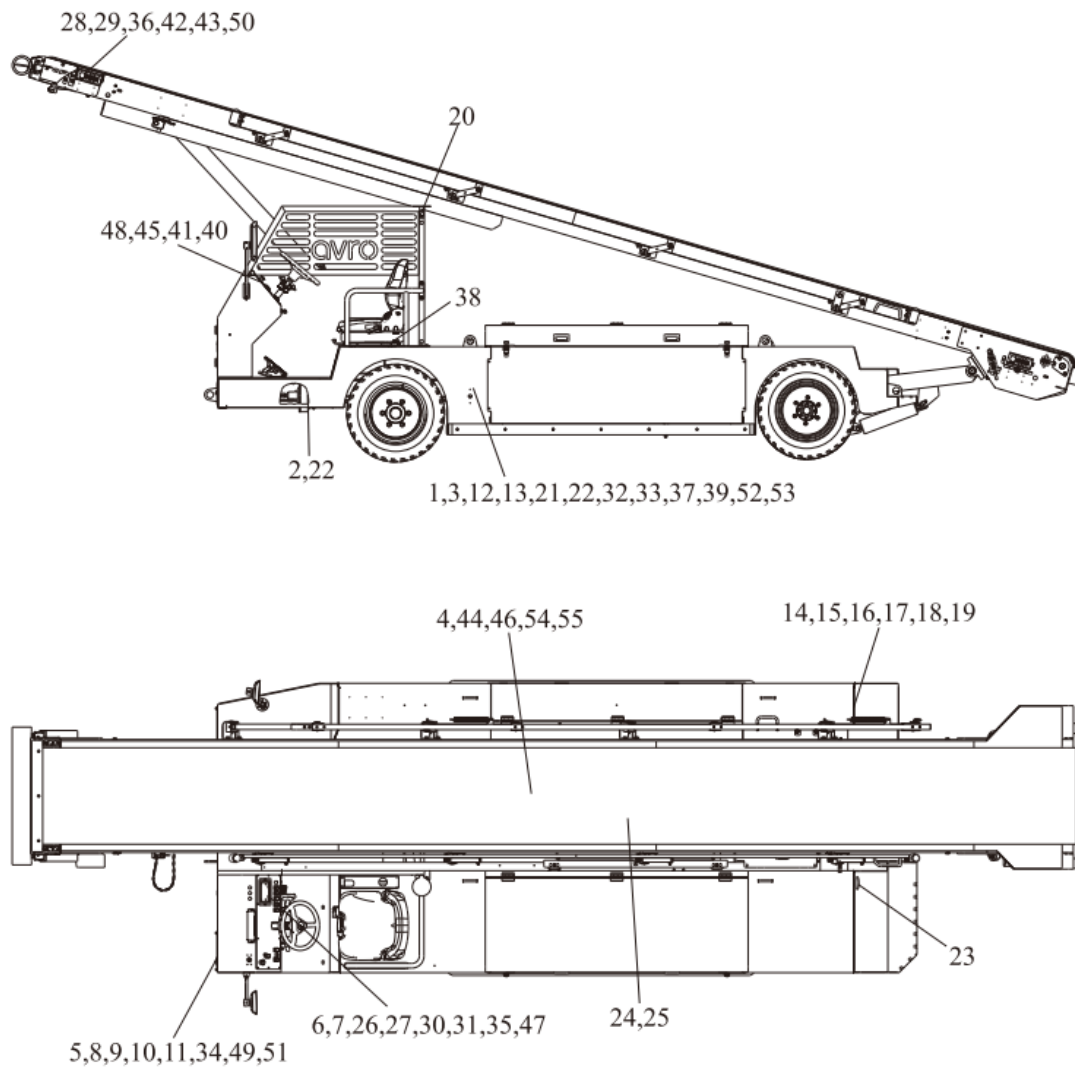

Electrical system - Exploded Parts View

Electrical System – Spare Parts List

Item	Part No.	Description	Qty	Remarks
34	PRPW02861	Turn Signal	2	
35	PRPW02846	Light Switch	1	
36	PRPW00436	Rear Light	1	
37	PRPW00693	High Turn Signal	2	
38	PRPW00676	Park Brake Switch	1	
39	PRPW02521	Five-Core Relay	3	
40	PRPW00958	Connector, Interlock Button Switch	1	
41	PRPW00957	Lift Cylinder Interlock Switch, Momentary, Green	1	
42	PRPW00107	Forward/Reverse Switch, Green Button	4	
43	PRPW00042	Belt stop switch – Momentary	2	
44		Fuel Sensor	1	B80F2-50100
45	PRPW02844	Flash Buzzer	2	
46		Preheating Relay	1	A30AB2-60200
47		E-Stop Indicator Sign	1	B80J2-60101
48		Blocking Cover	2	B80C2-60501
49	PRPW02856	Horn Filter	1	
50	PRPW02404	Belt Frame Harness	1	
51	PRPW03182	Liquid Level Sensor, Plug-in	1	
52	PRPW02333	Fuse Wire, 60A	1	
53	PRPW02869	Fuse Link Wire	1	
54		TABP Sensor	1	B80J2-50100
55		Water Level Sensor	1	A45P2-50100
56		Negative Power Cable	1	B80J2-80201
57		Positive Power Cable	1	B80J2-80202
58		Generator Cable	1	B80J2-80203
59		I Preheat Wire	1	B80J2-80301
60		II Preheat Wire	1	B80J2-80302
61		III Preheat Wire	1	B80J2-80303

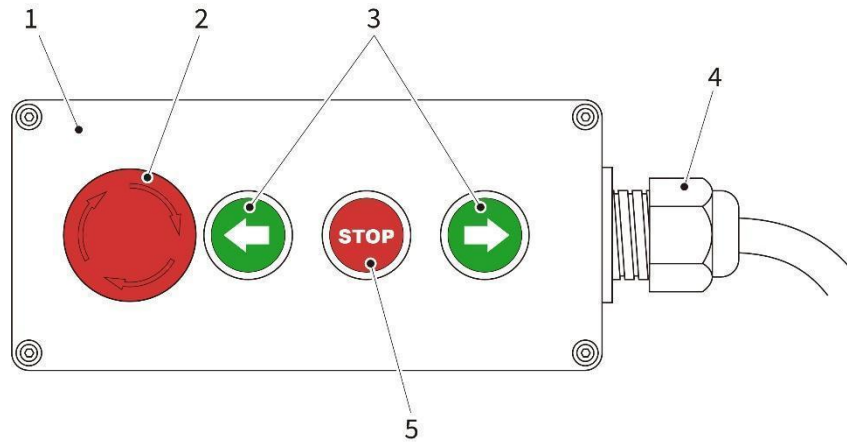

Belt Control Box - Exploded Parts View

Belt Control Box – Spare Parts List

Item	Part No.	Description	Qty	Remarks
1	PRPW00021	Belt Control Box	2	
2	PRPW00682	EMERGENCY STOP switch	2	
3	PRPW00107	Forward/Reverse Switch, Button	4	
4	PRPW02404	Belt Frame Harness	1	
5	PRPW00042	Stop Switch, Conveyor Belt Movement	2	

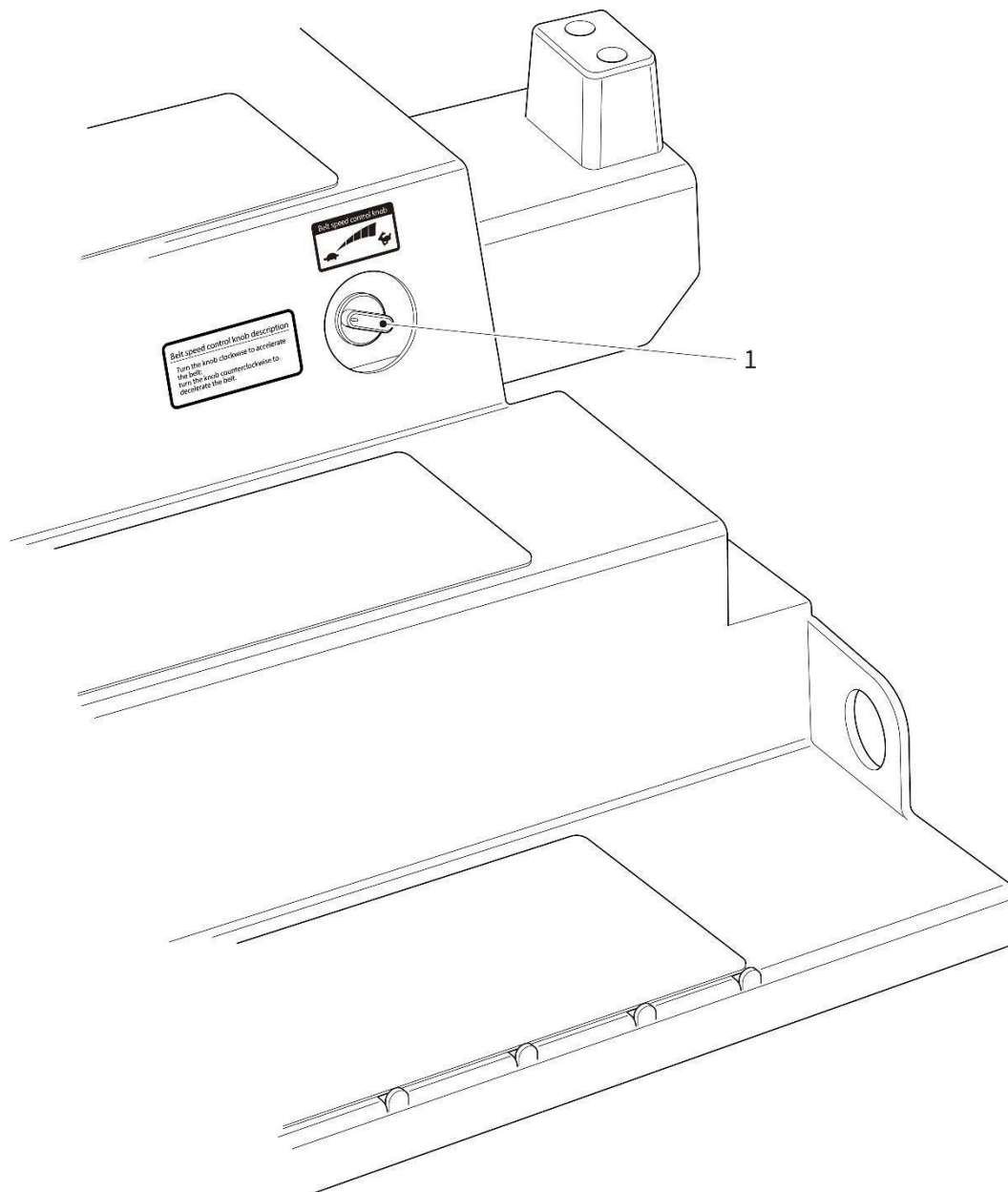

Belt Speed Control - Exploded Parts View

Belt Speed Control – Spare Parts List

Item	Part No.	Description	Qty	Remarks
1	PRPW00007	Throttle Control, Rear	1	

ENGINE MOUNTING

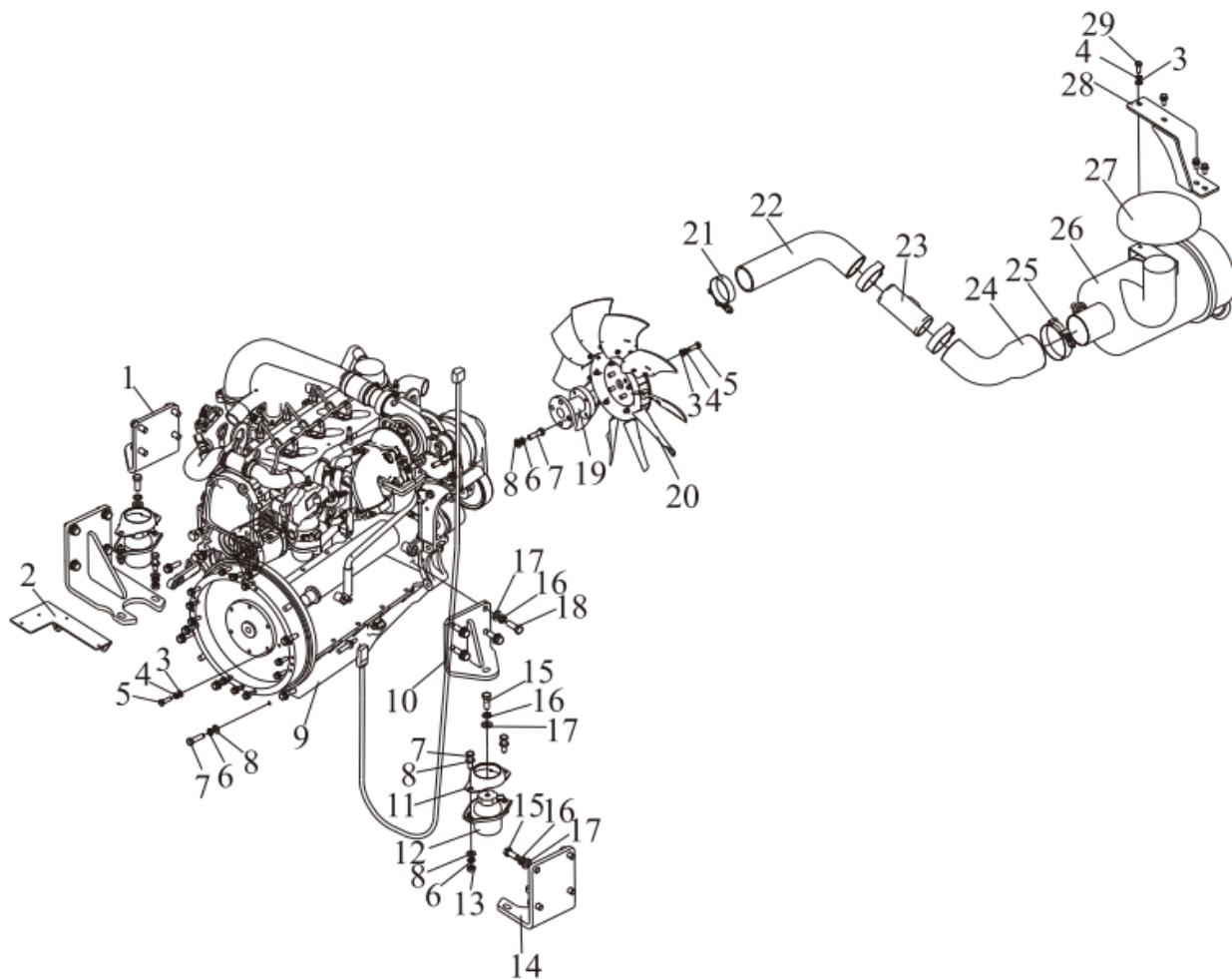

Engine Mounting - Exploded Parts View

Engine Mounting – Spare Parts List

Item	Part No.	Description	Qty	Remarks
1		Engine Left Bracket	1	B80F5-10100
2		Relay Bracket	1	B80J5-10004
3	PRFA00009	Washer, Flat, M8	20	
4	PRFA00010	Washer, Lock, M8	20	
5	PRFA00013	Bolt, M8 x 25 mm	16	
6	PRFA00012	Washer, Lock, M10	17	
7	PRFA00026	Bolt, M10 x 35 mm	17	
8	PRFA00011	Washer, Flat, M10	21	
9		Engine Assembly	1	B80J5-10100
10		Engine Strutting	2	B80J5-10200
11	PRPW02882	Protective Shell, Steel	2	
12	PRPW00723	Shock Absorber	2	
13	PRFA00036	Nut, M10	4	
14		Engine Bracket, Right Hand	1	B80F5-10200
15	PRFA00183	Bolt, M12 x 30 mm	10	
16	PRFA00034	Washer, Lock, M12	18	
17	PRFA00030	Washer, Flat, M12	18	
18	PRFA00042	Bolt, M12 x 35mm	8	
19		Fan Block	1	B80D5-10002
20		Suction Fan	1	T20T5-10005
21		Clip, 65 x 57	3	8JE08-06508
22		Air Filter Intake Pipe	1	B80J5-10002
23		Intake Steel Pipe	1	Y35D5-10004
24		II Air Filter Intake Pipe	1	B80J5-10003
25		Clip, 88 x 80	1	8JE08-08808
26		Air Filter (Iron Case)	1	B80F5-10005
27		Rainhat	1	B80F5-10004
28		Air Filter Bracket	1	B80J5-10300
29	PRFA00033	Bolt, M8 x 20 mm	4	

COOLING SYSTEM

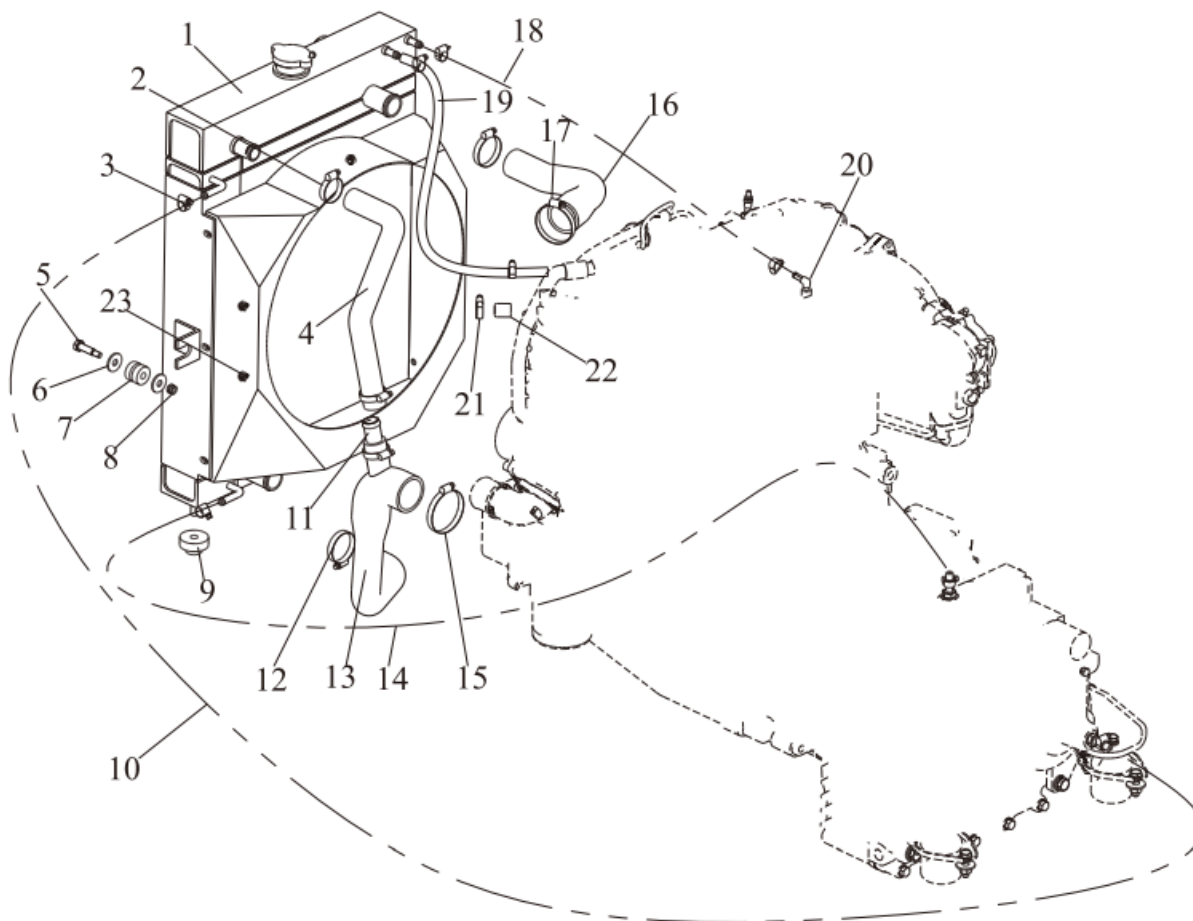

Cooling System - Exploded Parts View

Cooling System – Spare Parts List

Item	Part No.	Description	Qty	Remarks
1		Combine Radiator	1	B80J5-40100
2	PRPW02888	Clamp, Hose, 40 x 25 mm	3	
3	PRPW00879	Clip, Hose, 16 x 10mm	8	
4		Filling Water Pipe	1	B80J5-40003
5	PRFA00026	Bolt, M10 x 35 mm	2	
6		Washer, 10	4	GB/T 96
7	PRPW00733	Rubber Mounting	2	
8	PRFA00186	Nut, Self-locking, M8	2	
9	PRPW00736	Anti-vibration Mount, Radiator	2	
10		Transmission Tubing	1	TGCDY-10250
11		Straight-Through Nozzle, 25	1	B80J5-40004
12	PRPW02888	Clip, 40 x 25	2	
13		Hose Rubber	1	B80J5-40001
14		Transmission Tubing	1	TGCDY-10150
15	PRPW02395	Clamp, Hose, 70 x 50 mm	1	
16		Hose Rubber	1	B80J5-40002
17	PRPW00126	Clamp, Hose, 64 x 44 mm	1	
18		Antifreeze Tube, dia. 10 x 650 mm	1	TGFDY-10065
19		I Exhaust Nozzle	1	B80J5-40005
20		Elbow	1	GJT-892-00
21	PRPW02883	Clamp, Hose, 25 x 16 mm	1	
22		Pipe Plug Cap	1	B80J5-40006
23		Cable Tie Base Buckle	3	A25AL2-20008

FUEL SYSTEM

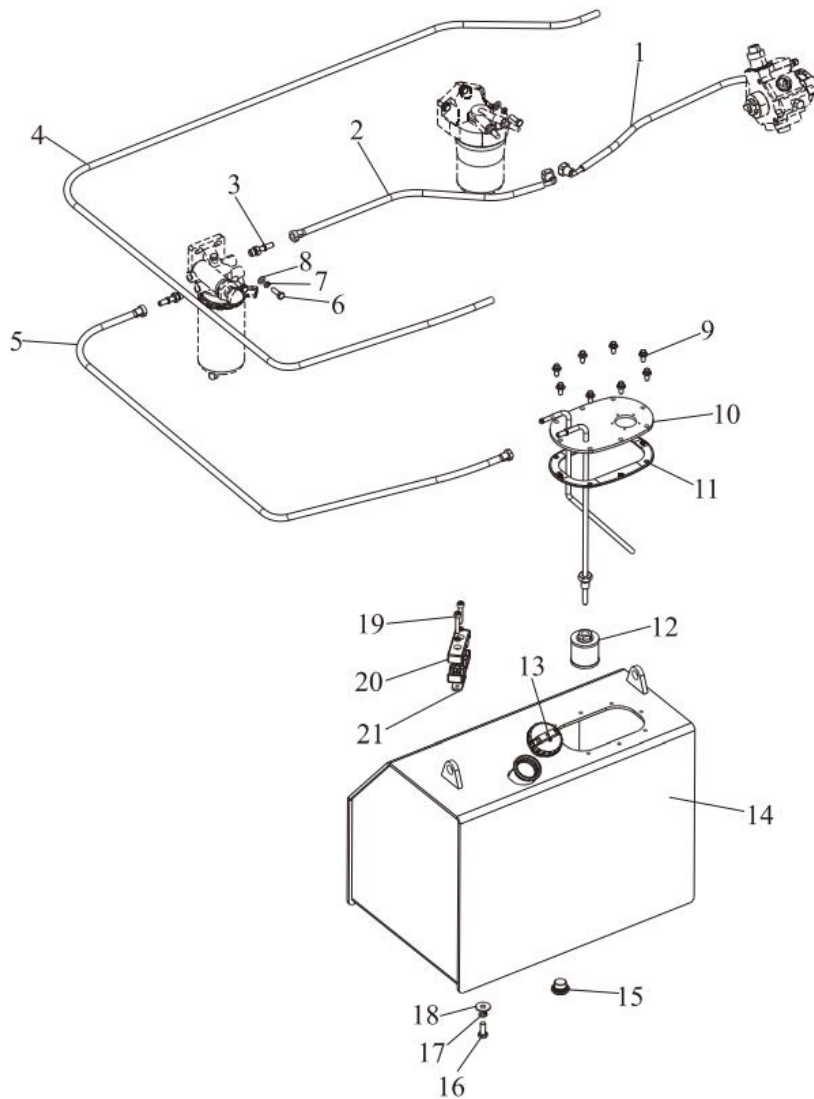

Fuel System - Exploded Parts View

Fuel System – Spare Parts List

Item	Part No.	Description	Qty	Remarks
1		II Hose	1	B80J5-30200
2		I Hose	1	B80J5-30100
3		Filtration Joint	2	A45P5-30002
4		Return Tubing	1	B80D5-30003
5		III Hose	1	B80J5-30300
6	PRFA00013	Bolt, M8 x 25 mm	5	
7	PRFA00010	Washer, Lock, M8	7	
8	PRFA00009	Washer, Flat, M8	5	
9	PRFA00024	Bolt, M8 x 16 mm	8	
10		Cover Assembly	1	B80F5-30200
11	PRPW00740	Sealing Gasket	1	
12	PRPW00070	Fuel pre-filter, in-tank	1	
13	PRPW00056	Fuel Cap	1	
14		Fuel Tank Assembly	1	B80F5-30100
15	PRPW00751	Drain Plug	1	
16	PRFA00063	Bolt, M10 x 25 mm	4	
17	PRFA00012	Washer, Lock, M10	4	
18		Washer, 10	4	GB/T 96
19		Screw, M8 x 40 mm	2	GB/T 70.1
20	PRPW03008	Pipe Clamp	2	
21		Thread Plate	1	B80J5-30002

EXHAUST SYSTEM

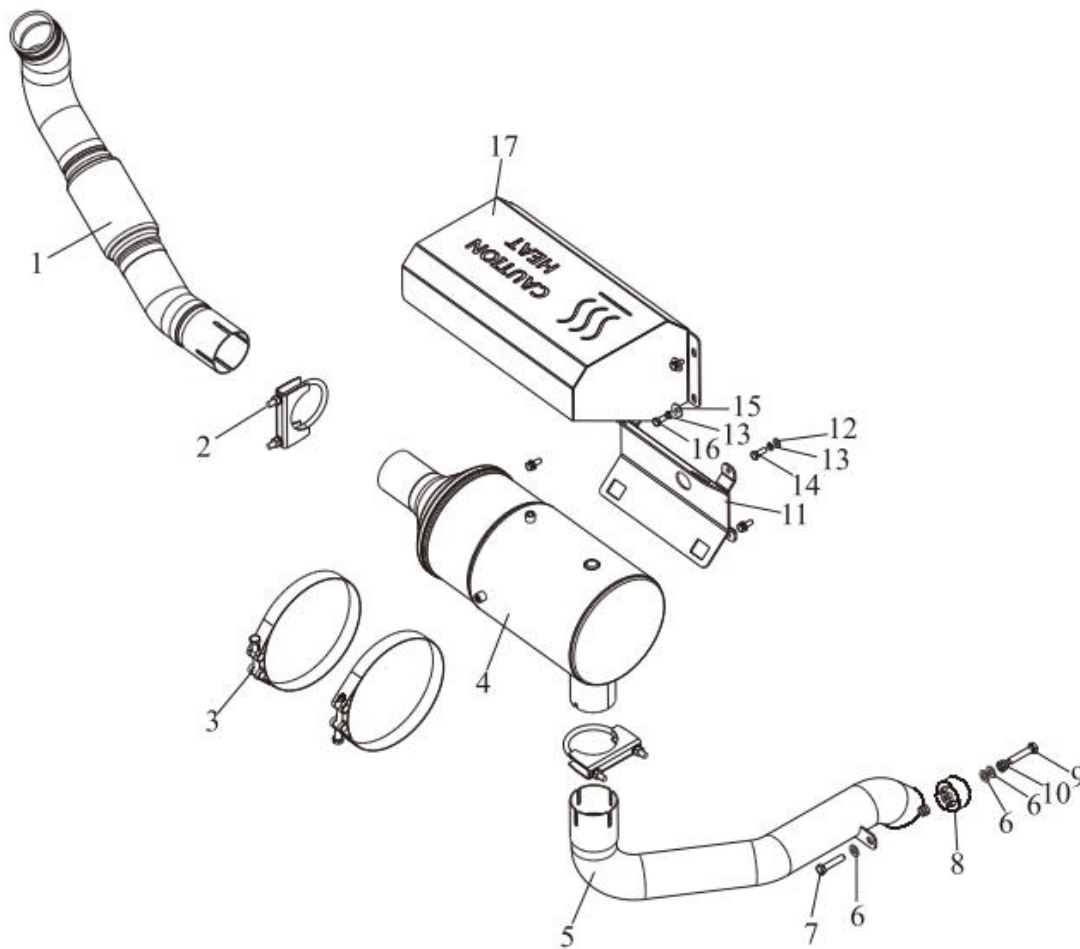

Exhaust System - Exploded Parts View

Exhaust System – Spare Parts List

Item	Part No.	Description	Qty	Remarks
1		Exhaust Pipe	1	B80J5-20100
2		Pipe Clamp	2	A120A5-20500
3		201-213 Embrace Hoop	2	B80J5-20500
4		DOC Assembly	1	B80J5-20400
5		Tail Pipe	1	B80J5-20300
6	PRFA00011	Washer, Flat, M10	4	
7		Bolt, 10 x 24	1	GB/T 5783
8	PRPW00758	Exhaust Rubber Mounting	1	
9	PRFA00195	Bolt, 10 x 50	1	
10	PRFA00036	Nut, M10	2	
11		Catalyst Support	1	B80J5-20200
12	PRFA00009	Washer, Flat, M8	4	
13	PRFA00010	Washer, Lock, M8	8	
14	PRFA00033	Bolt, M8 x 20 mm	4	
15	PRFA00009	Washer, Flat, M8	4	
16	PRFA00300	Bolt, M8 x 16 mm	4	
17		Shielf Welding	1	B80J5-20200

TRANSMISSION MOUNTING

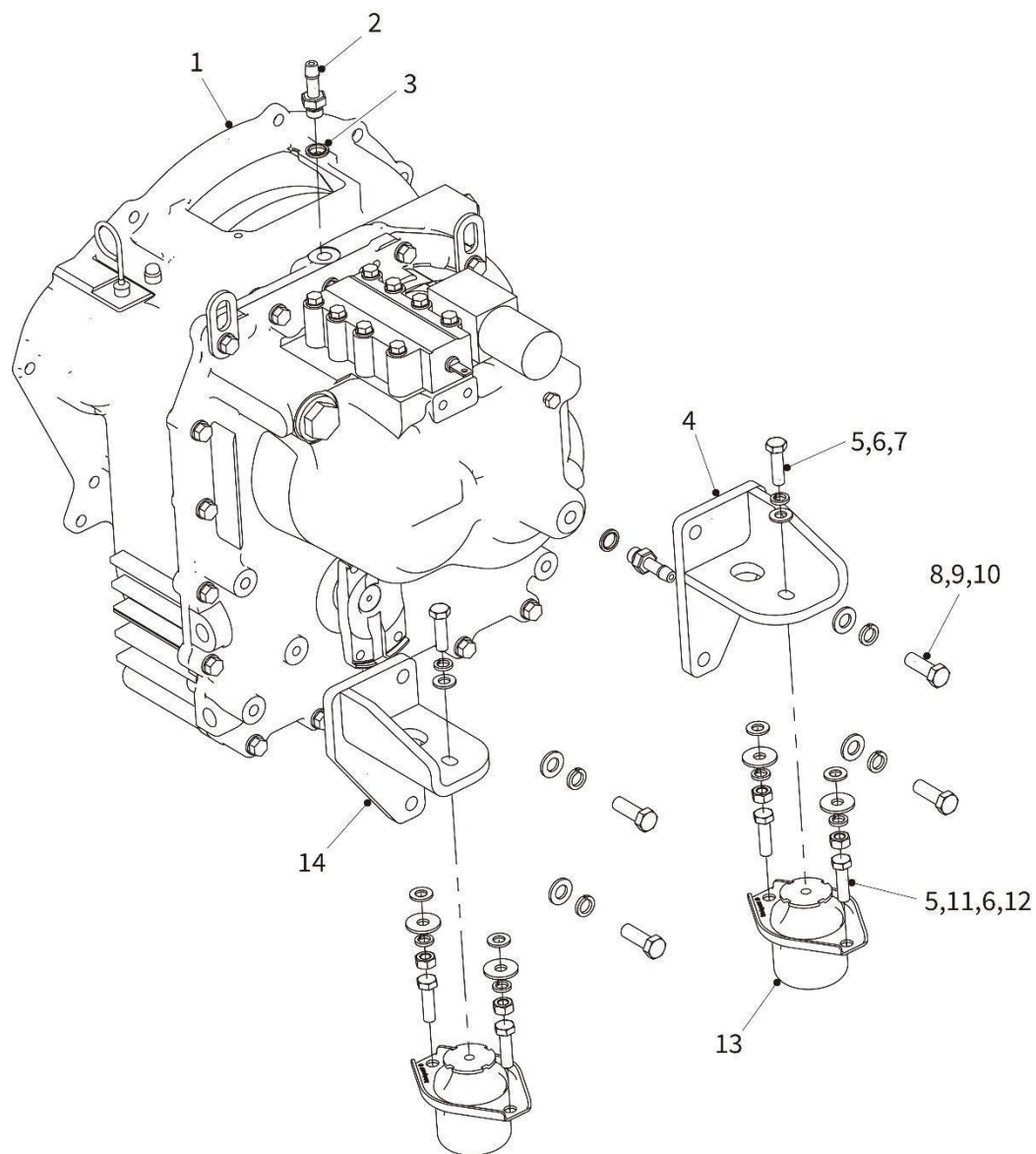

Automatic Transmission Mounting - Exploded Parts View

Automatic Transmission Mounting – Spare Parts List

Item	Part No.	Description	Qty	Remarks
1	PRPW02907	Transmission Assembly	1	
2	PRPW02908	Connector, Hydraulic, Straight	2	
3	PRPW02909	Gasket, M14	2	
4	PRPW02910	Transmission Mounting Bracket, Right-Side	1	
5	PRFA00026	Bolt, M10 x 35 mm	6	
6	PRFA00012	Washer, Lock, M10	6	
7	PRFA00011	Washer, Flat, M10	6	
8	PRFA00042	Bolt, M12 x 35 mm	4	
9	PRFA00034	Washer, Lock, M12	4	
10	PRFA00030	Washer, Flat, M12	4	
11	PRFA00036	Nut, M10	4	
12	PRFA00011	Washer, Flat, M10	4	
13	PRPW00767	Gearbox Mounting	2	
14	PRPW02911	Transmission Mounting Bracket, Left-Side	1	

DRIVETRAIN

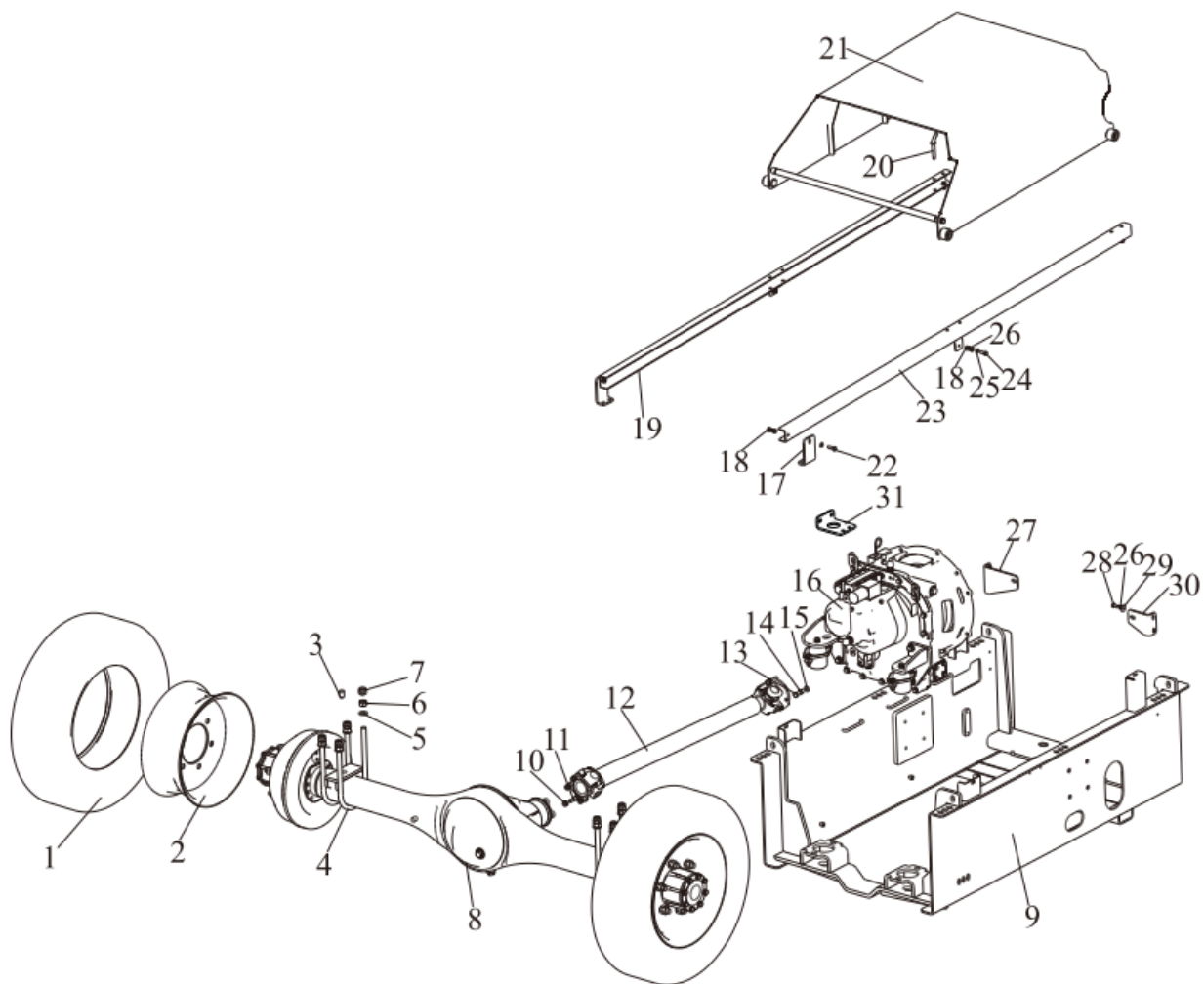

Drivetrain - Exploded Parts View

Drivetrain – Spare Parts List

Item	Part No.	Description	Qty	Remarks
1	PRPW03089	Tire, 225/70R15	2	
2	PRPW02746	Rim Assembly, 6J x 15	2	
3	PRPW02922	Fixed Pin	2	
4	PRPW02921	U Bolt	4	
5	PRFA00068	Washer, Flat, M16	8	
6	PRFA00291	Nut, M16 x 1.5	8	
7	PRFA00079	Nut, M16 x 1.5	8	
8	PRPW02920	Drive Axle, 5.83	1	
9		Transmission Case	1	B80J5-00100
10	PRFA00036	Nut, M10	4	
11	PRFA00254	Bolt, Drive Shaft	4	
12	PRPW00012	Drive shaft with u-joints	1	
13	PRFA00256	Front Drive Shaft Bolt	4	
14	PRFA00012	Washer, Lock, M10	4	
15	PRFA00011	Washer, Flat, M10	4	
16	PRPW02919	Transmission Installation	1	
17	PRPW02923	Plate	2	
18	PRFA00021	Nut, M8	6	
19		Side Rail Support (L)	1	B80D5-00700L
20		Latch Assembly	1	B80D5-00900
21		Engine Hood Assembly	1	B80J5-00200
22	PRFA00013	Bolt, M8 x 25 mm	2	
23		Side Rail Support (R)	1	B80D5-00700R
24	PRFA00033	Bolt, M8 x 20 mm	4	
25	PRFA00009	Washer, Flat, M8	12	
26		Washer, Lock, 8	10	GB/T 97.1
27		Radiator Fixed Plate L	1	B80J5-00001L
28	PRFA00300	Bolt, M8 x 16 mm	4	
29	PRFA00009	Washer, Flat, M8	4	
30		Radiator Fixed Plate R	1	B80J5-00001R
31		Filter Mounting Plate	1	B80K5-00001

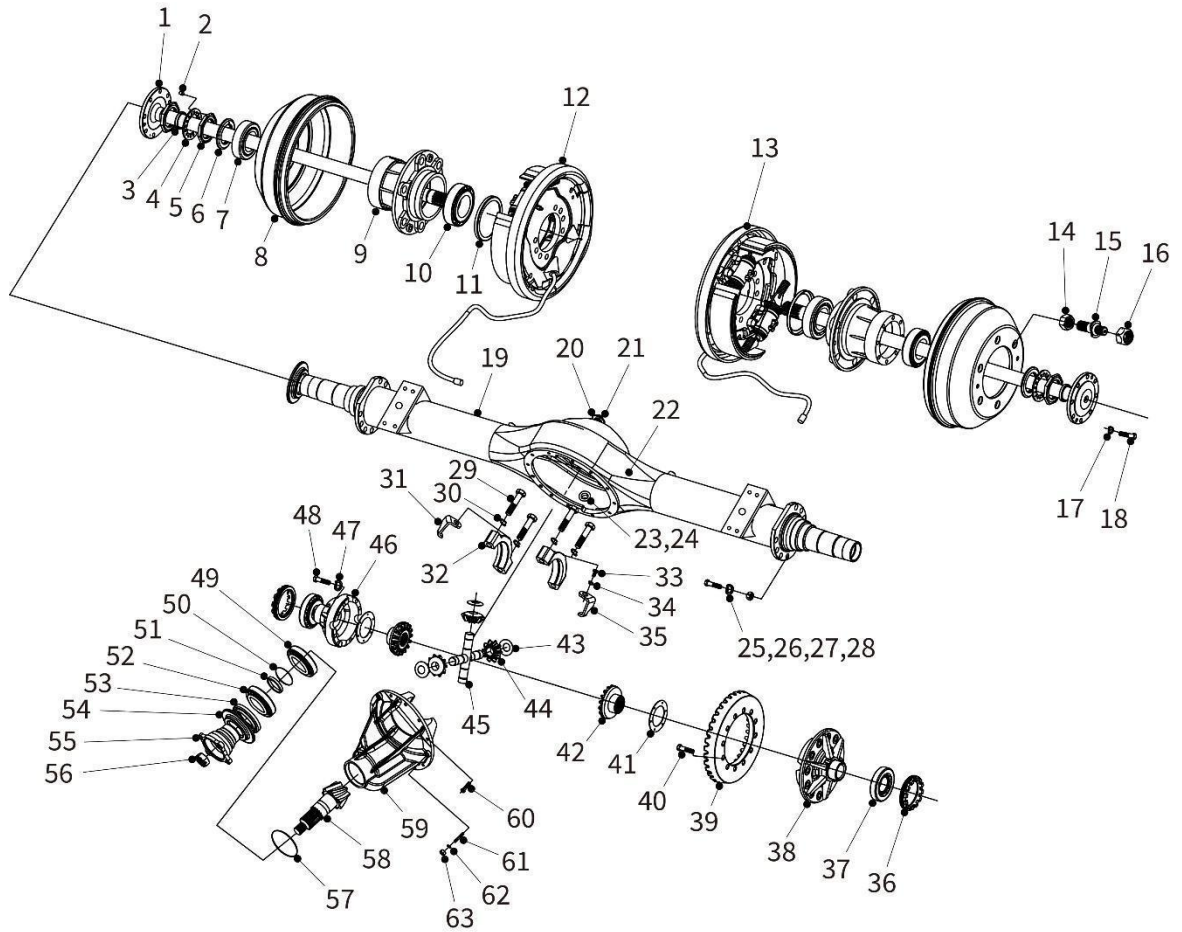

Drive Axle - Exploded Parts View

Drive Axle – Spare Parts List

Item	Part No.	Description	Qty	Remarks
1	PRPW02926	Axle Shaft, Rear	2	
2	PRPW02927	Cylindrical Pin	4	
3	PRPW02928	Oil Seal, Inner	2	
4	PRPW02929	Shaft Gasket	2	
5	PRPW02930	Hub Bearing, Rear Axle	2	
6	PRPW02931	Bush, Oil Seal	2	
7	PRPW02933	Outer Wheel Bearing, Single Row Tapered Roller Bearing, Type 32211, i.d. 55 mm, o.d. 100 mm, total width 26.75 mm, inner ring chamfer 2.0 mm (min.), outer ring chamfer 1.5 mm (min.)	2	
8	PRPW00446	Rear Brake Drum	2	
9	PRPW02934	Rear Hub	2	
10	PRPW02935	Inner Wheel Bearing, Single Row Tapered Roller Bearing, Type 32212, i.d. 60 mm, o.d. 110 mm, total width 29.75 mm, inner ring chamfer 2.0 mm (min.), outer ring chamfer 1.5 mm (min.)	2	
11	PRPW02936	Oil Seal, Inner	2	
12	PRPW00347	Rear Brake Assembly, Right-Hand	1	
13	PRPW00403	Rear Brake Assembly, Left-Hand	1	
14	PRPW02948	Wheel Nut, Inner	12	
15	PRPW02904	Wheel Stud, Left-hand thread	6	
	PRPW02903	Wheel Stud, Right-hand thread	6	
16	PRPW02947	Wheel Nut, M18 x 25 mm, Left-hand thread	6	
	PRPW02949	Wheel Nut, M18 x 25 mm, Right-hand thread	6	

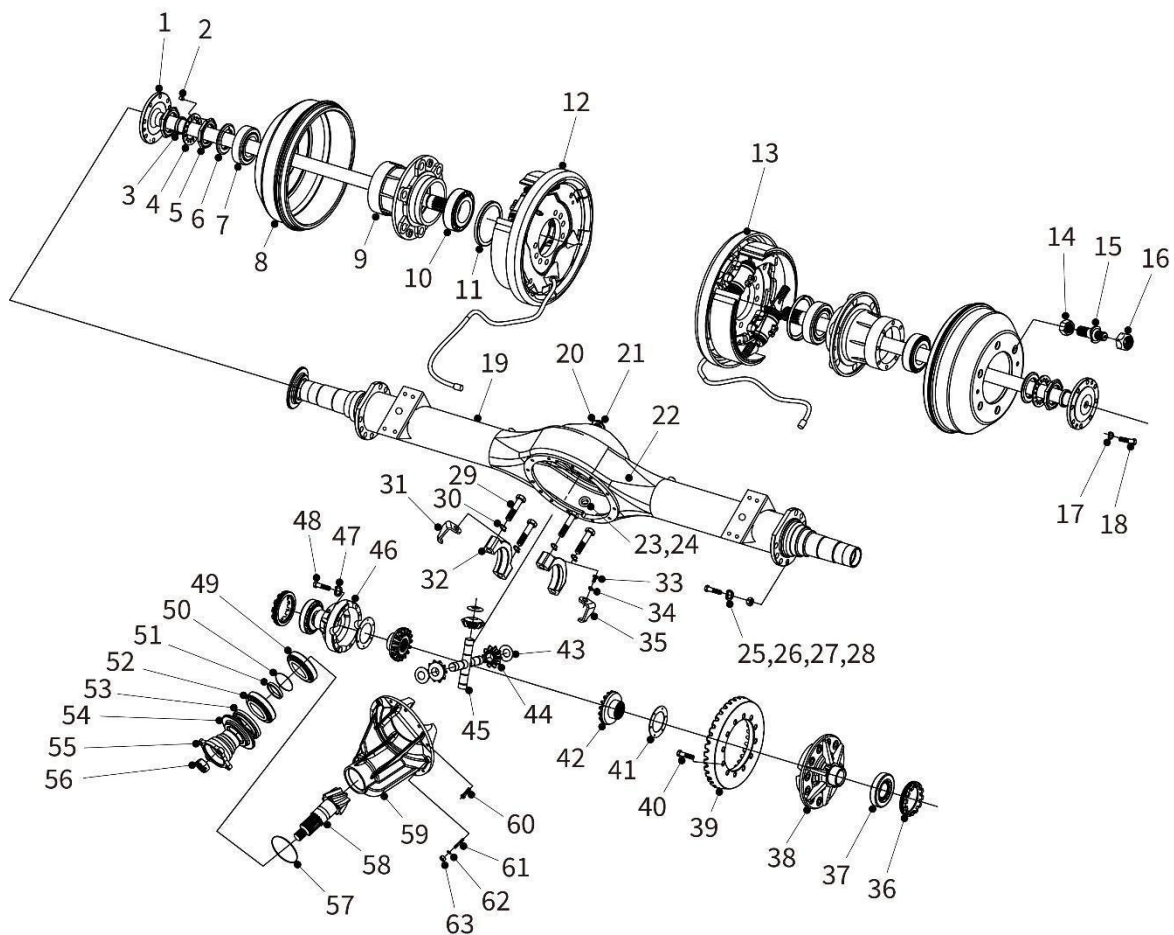

Drive Axle - Exploded Parts View

Drive Axle – Spare Parts List

Item	Part No.	Description	Qty	Remarks
18	PRFA00259	Bolt, Shaft	16	
19	PRPW02937	Shell Assembly, Rear Axle	1	
20	PRPW02951	Sealing Washer	1	
21	PRPW02938	Oil Filler Plug	1	
22	PRPW02939	Magnet, Metallic Debris Collection	1	
23	PRPW02953	Oil Plug, Type G1/8	1	
24	PRPW02952	Sealing Washer	1	
25	PRFA00266	Bolt, Axle, Special, No. 1	8	
26	PRFA00267	Bolt, Axle, Special, No. 2	8	
27	PRFA00269	Spring Washer, Heavy duty, Special	16	
28	PRFA00270	Nut, Special	16	
29	PRPW02954	Bolt, Bearing Cover	4	
30	PRFA00269	Spring Washer, Heavy duty, Special	4	
31	PRPW02950	Shim, Right-hand, for Adjusting Nut	1	
32	PRPW02956	Cover, Bearing	2	
33	PRFA00271	Bolt, Special	2	
34	PRFA00272	Washer, Spring	2	
35	PRPW02961	Shim, Left-hand, for Adjusting Nut	1	

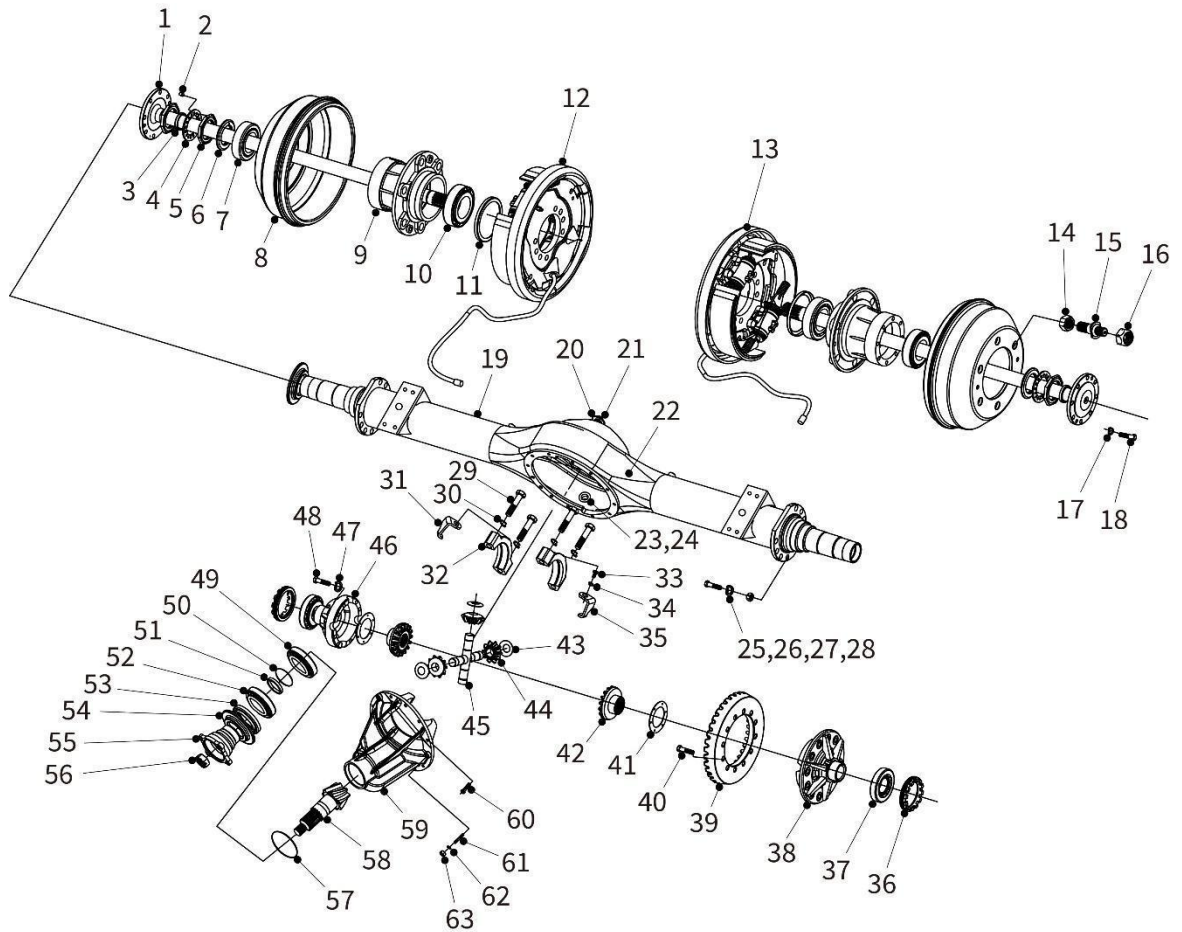

Drive Axle - Exploded Parts View

Drive Axle – Spare Parts List

Item	Part No.	Description	Qty	Remarks
36	PRFA00251	Adjusting Nut	2	
37	PRPW02962	Compensating Gear Bearing, Single Row Tapered Roller Bearing, Type 32210, i.d. 50 mm, o.d. 90 mm, total width 24.75 mm, inner ring chamfer 1.5 mm (min.), outer ring chamfer 1.5 mm (min.)	2	
38	PRPW02964	Dispatch Gear, Left-hand	1	
39	PRPW03165	Driven Gear	1	
40	PRFA00250	Bolt, Special	8	
41	PRPW03166	Spacer	2	
42	PRPW03167	Gear	2	
43	PRPW03168	Shim	4	
44	PRPW03169	Epicyclic Gear	4	
45	PRPW03170	Gear Axle	2	
46	PRPW03171	Dispatch Gear, Right-hand	1	
47	PRFA00314	Spring Washer, Heavy duty, Special, Type Q40510	8	
48	PRFA00315	Bolt, Compensating Gear	8	
49	PRPW03172	Single Row Tapered Roller Bearing, Type 30307, i.d. 35 mm, o.d. 80 mm, total width 22.75 mm, inner ring chamfer 2.0 mm (min.), outer ring chamfer 1.5 mm (min.)	1	
50	PRPW03173	Shim	As reqd.	

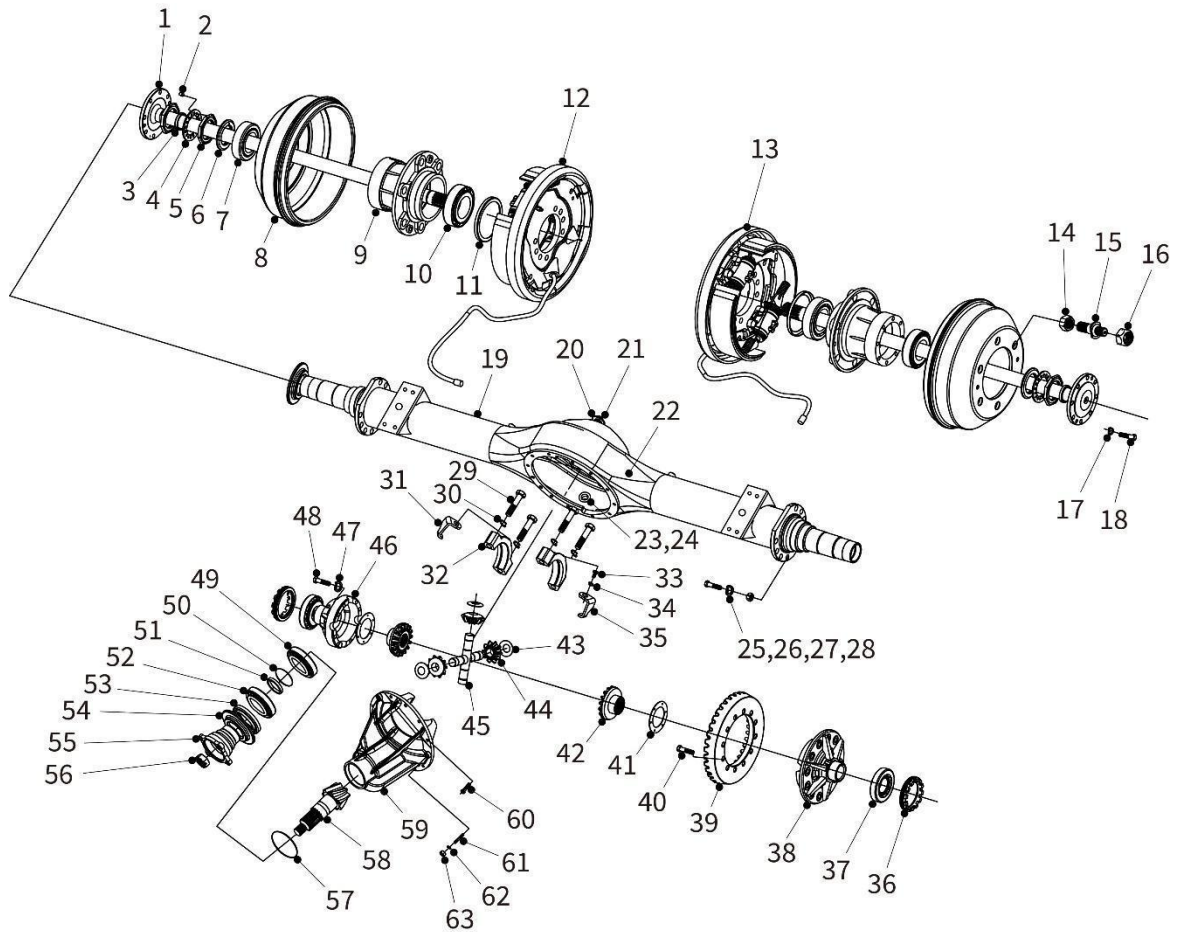

Drive Axle - Exploded Parts View

Drive Axle – Spare Parts List

Item	Part No.	Description	Qty	Remarks
51	PRPW03174	Spacer	1	
52	PRPW03175	Shim	As reqd.	
53	PRPW03176	Seal	1	
54	PRPW03177	Dust Cover, Differential Flange	1	
55	PRPW03178	Flange, Differential	1	
56	PRFA00316	Nut, Special	1	
57	PRPW03179	Shim	1	
58	PRPW03180	Pinion Gear	1	
59	PRPW03181	Housing, Differential	1	
60	PRFA00293	Bolt, Special	10	
61	PRFA00294	Bolt, Special	2	
62	PRFA00260	Spring Washer, Heavy duty, Special	12	
63	PRFA00209	Nut, Special	2	

BRAKING SYSTEM

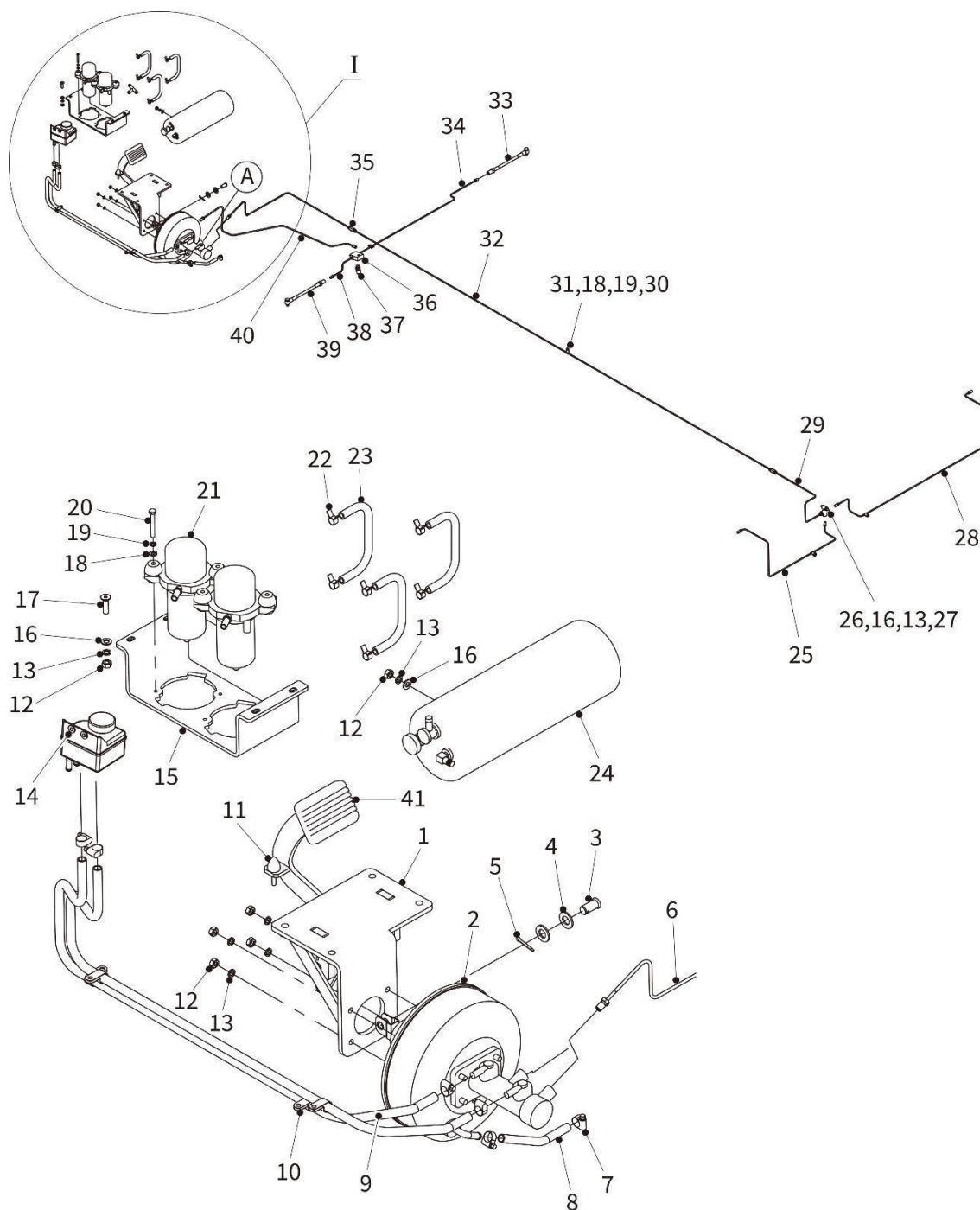

Brake System - Exploded Parts View

Brake System – Spare Parts List

Item	Part No.	Description	Qty	Remarks
1	PRPW03184	Foot Brake Support Assembly	1	
2	PRPW03185	Brake Master Cylinder Assembly	1	
3	PRPW03186	Split Cotter Pin	1	
4	PRFA00072	Washer, Flat, M14	2	
5	PRPW03186	Split Cotter Pin	1	
6	PRPW03187	Brake Pipe D	1	
7	PRPW00879	Clip, Hose, 16 x 10 mm	6	
8	PRPW03188	Hose, Brake, $\phi 10$ x 500 mm	1	
9	PRPW03189	Hose, Brake, $\phi 10$ x 1120 mm	2	
10	PRPW03190	Hose Clamp, 16 mm	4	
11	PRPW03191	Cone Pad	1	
12	PRFA00021	Nut, M8	6	
13	PRFA00010	Washer, Lock, M8	8	
14	PRPW00461	Brake Fluid Reservoir	1	
15	PRPW03193	Bracket, Fixed	1	
16	PRFA00009	Washer, Flat, M8	4	
17	PRFA00312	Screw, Hex Socket Countersunk Head, M8 x 20 mm	1	
18	PRFA00006	Washer, Flat, M6	14	
19	PRFA00007	Washer, Lock, M6	14	
20	PRFA00064	Bolt, M6 x 45mm	4	
21	PRPW02945	Vacuum Pump	2	
22	PRPW03194	Clamp, Hose, dia. 11 mm	6	
23	PRPW00819	Tube, dia. 7mm	3	
24	PRPW02946	Vacuum Accumulator Tank	1	
25	PRPW03195	Brake Pipe, G	1	
26	PRPW03196	Connector, Hydraulic, Three-Way	2	
27	PRFA00047	Bolt, M8 x 35mm	2	
28	PRPW03197	Brake Pipe, H	1	

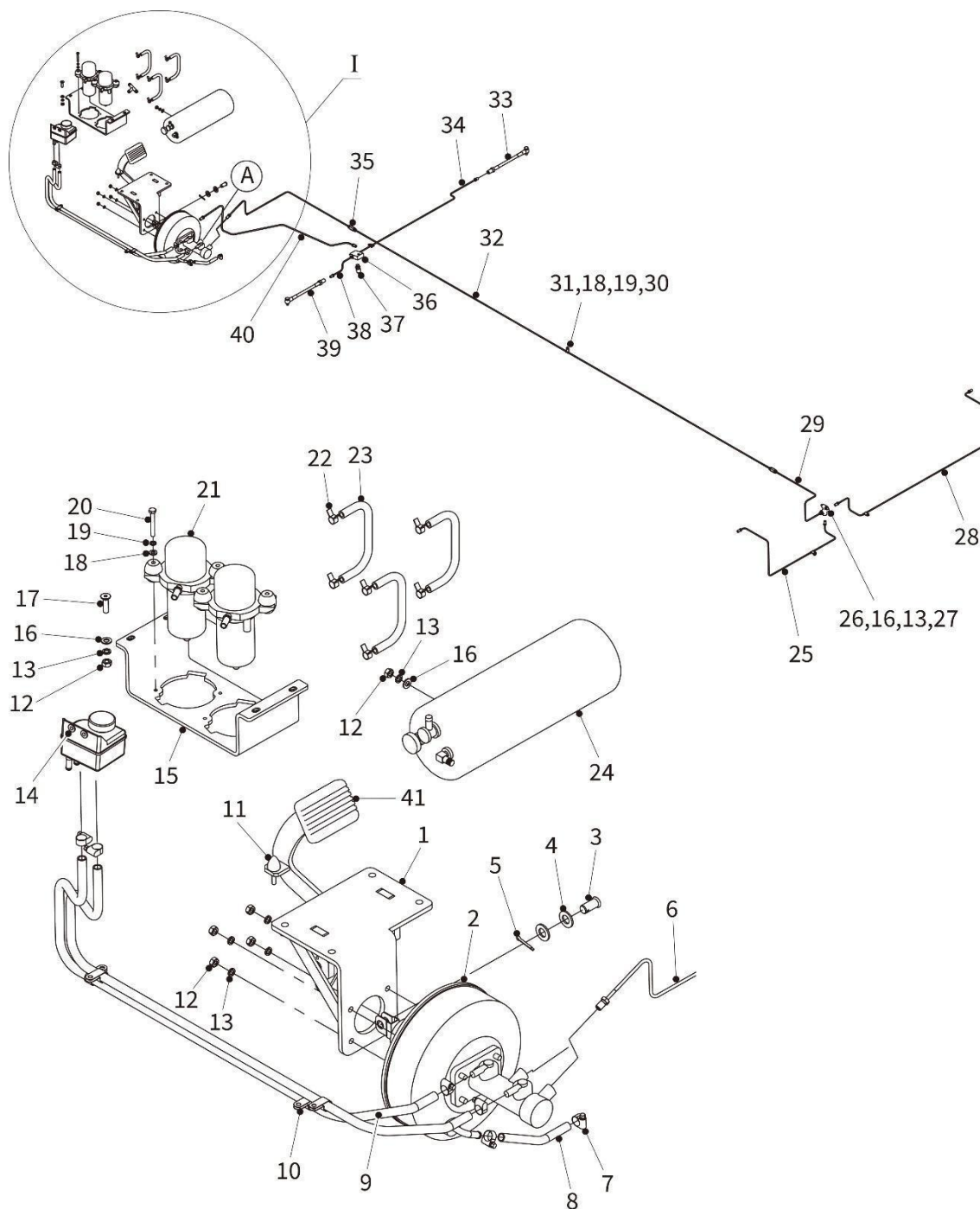

Brake System - Exploded Parts View

Brake System – Spare Parts List

Item	Part No.	Description	Qty	Remarks
29	PRPW03198	Brake Pipe, F	1	
30	PRFA00130	Bolt, M6 x 12 mm	10	
31	PRPW00814	Clamp, Brake Pipe, $\phi 6$	10	
32	PRPW03199	Brake Pipe, E	1	
33	PRPW03200	Brake Hose	1	
34	PRPW03201	Brake Pipe, C	1	
35	PRPW03202	Connector, Straight	2	
36	PRPW03203	Connector, Brake	1	
37	PRPW03204	Test Point, Hydraulic	1	
38	PRPW03205	Brake Pipe, B	1	
39	PRPW03206	Brake Hose	1	
40	PRPW03207	Brake Pipe, A	1	
41	PRPW03211	Brake Pedal Rubber Cover	1	

STEERING SYSTEM

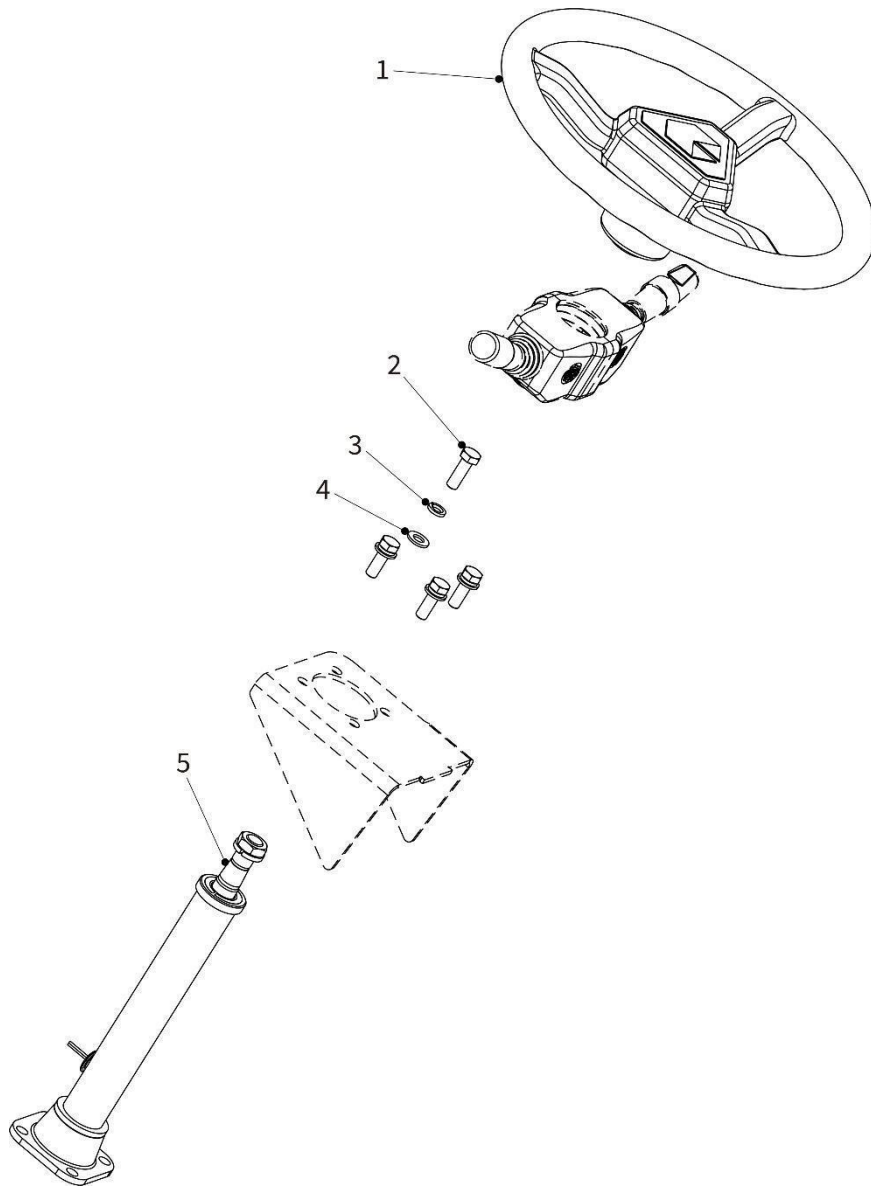

Steering Column - Exploded Parts View

Steering Column – Spare Parts List

Item	Part No.	Description	Qty	Remarks
1	PRPW00192	Steering Wheel Assembly	1	
2	PRFA00008	Bolt, M10 x 30 mm	4	
3	PRFA00012	Washer, Lock, M10	4	
4	PRFA00011	Washer, Flat, M10	4	
5	PRPW02965	Steering Column Assembly	1	

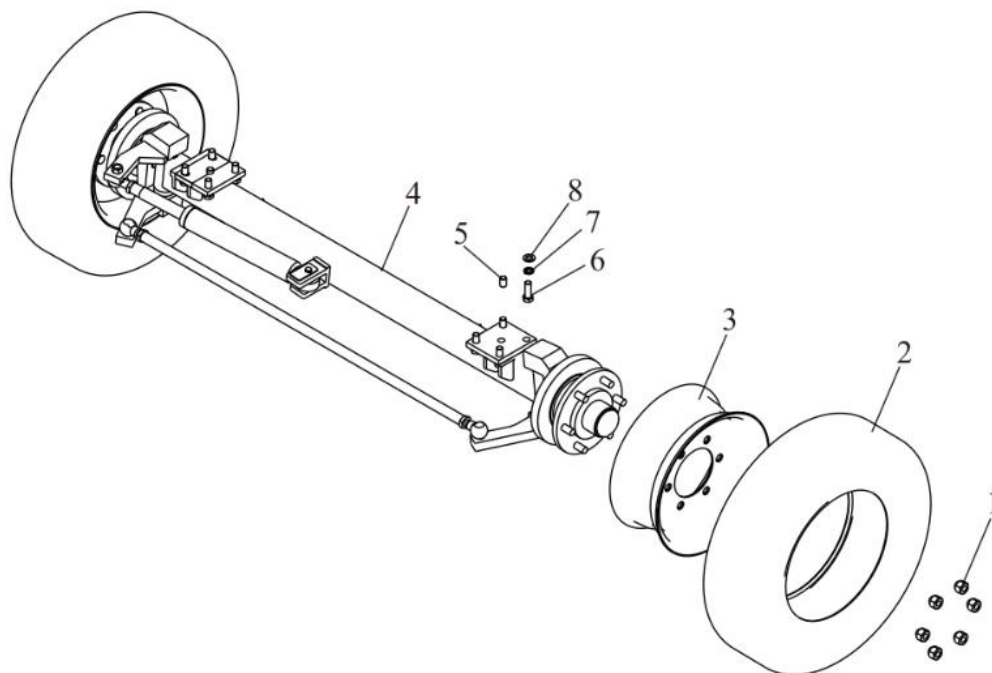

Steering Axle Assembly - Exploded Parts View

Steering Axle Assembly – Spare Parts List

Item	Part No.	Description	Qty	Remarks
1	PRFA00282	Rim Bolt, M18 x 25 mm	12	
2	PRPW03085	Tire, 225/70R15	2	
3	PRPW02746	Rim Assembly, 6J x 15	2	
4	PRPW02966	Steering Axle	1	
5	PRFA00273	Pin	2	
6	PRFA00274	Bolt, M16 x 45 mm	8	
7	PRFA00069	Washer, Lock, M16	8	
8	PRFA00068	Washer, Flat, M16	8	

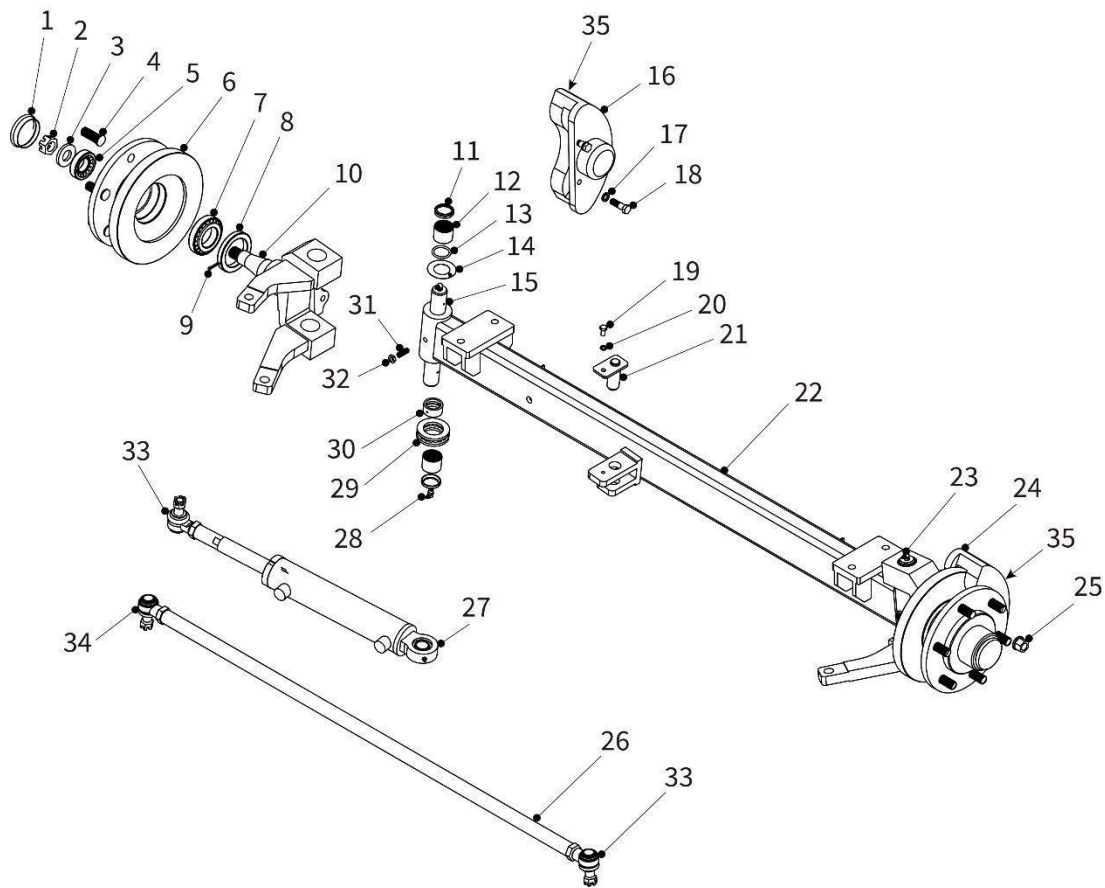

Steering Axle - Exploded Parts View

Steering Axle – Spare Parts List

Item	Part No.	Description	Qty	Remarks
1	PRPW02967	Cap	2	
2	PRFA00275	Nut, M24 x 2 mm	2	
3	PRFA00276	Nut, 26 x 50 x 6 mm	2	
4	PRFA00277	Bolt, M18 x 50 x 1.5 mm	12	
5	PRPW02968	Tapered Roller Bearing, Type 32206, single row, i.d. 30 mm, o.d. 62 mm, width 21.75 mm, chamfer 1.0 mm	2	
6	PRPW02969	Front Hub	2	
7	PRPW02970	Tapered Roller Bearing, Type 30209, single row, i.d. 45 mm, o.d. 85 mm, width 20.75 mm, chamfer 1.5 mm	2	
8	PRPW02971	Seal, Oil, 65 x 90 x 12 mm	2	
9	PRFA00278	Pin, 5 x 45 mm	2	
10	PRPW02972	Knuckle, Left-Hand	1	
11	PRPW02973	Seal, Oil	4	
12	PRPW02974	Needle Roller Bearing, Type 943/32, i.d. 32 mm, o.d. 39 mm, width 32 mm	4	
13	PRPW02975	O-Ring, dia. 31.80 mm x 4.80 mm	2	
14	PRPW02976	Shim	2	
15	PRFA00279	Pin, Special	2	
16	PRPW00010	Wheel Brake Assembly, Left-Hand (Comes complete with set of Brake Pads)	1	
17	PRFA00034	Washer, Lock, M12	4	
18	PRFA00134	Bolt, M12 x 1.25 x 40 mm	4	

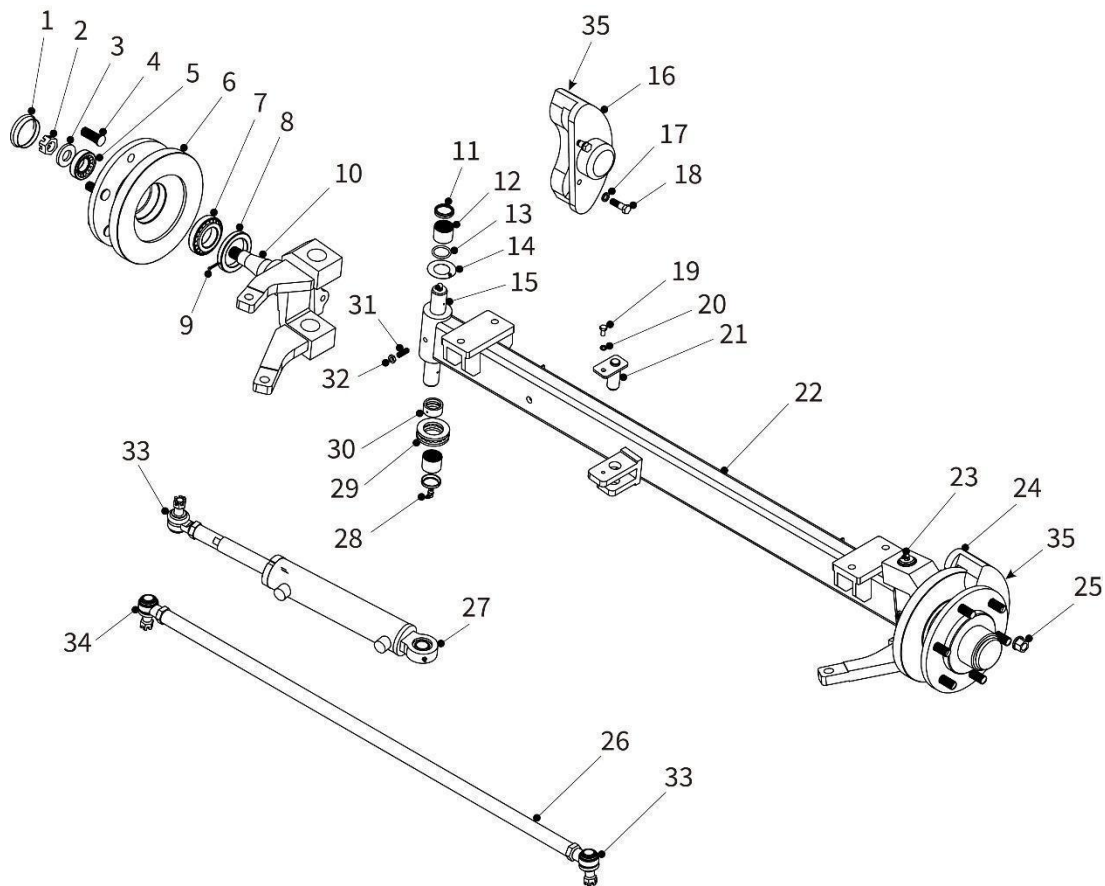

Steering Axle - Exploded Parts View

Steering Axle – Spare Parts List

Item	Part No.	Description	Qty	Remarks
19	PRFA00061	Bolt, M8 x 16mm	1	
20	PRFA00010	Washer, Lock, M8	1	
21	PRFA00281	Pin, Special	1	
22	PRPW02978	Front Axle	1	
23	PRPW02735	Knuckle, Right-Hand	1	
24	PRPW00009	Wheel Brake Assembly, Right-Hand (Comes complete with set of Brake Pads)	1	
25	PRFA00282	Rim Bolt, M18 x 25 mm	12	
26	PRPW02981	Track Rod	1	
27	PRPW02982	Steering Cylinder	1	
28	PRPW02983	Grease Nipple, 90 deg	4	
29	PRPW02984	Thrust Ball Bearing, Type 198908K, i.d. 38.5 mm, o.d. 66.7 mm, width 18 mm	2	
30	PRPW02985	Bushing, Thrust Bearing, Type A21B4-12001	2	
31	PRFA00283	Screw, M10 x 25 mm	2	
32	PRFA00036	Nut, M10	2	
33	PRPW02986	Ball Joint, Right-Hand	2	
34	PRPW02987	Ball Joint, left-Hand	1	
Not shown	PRPW00305	Front Brake Pad Kit	2	

HYDRAULIC SYSTEM

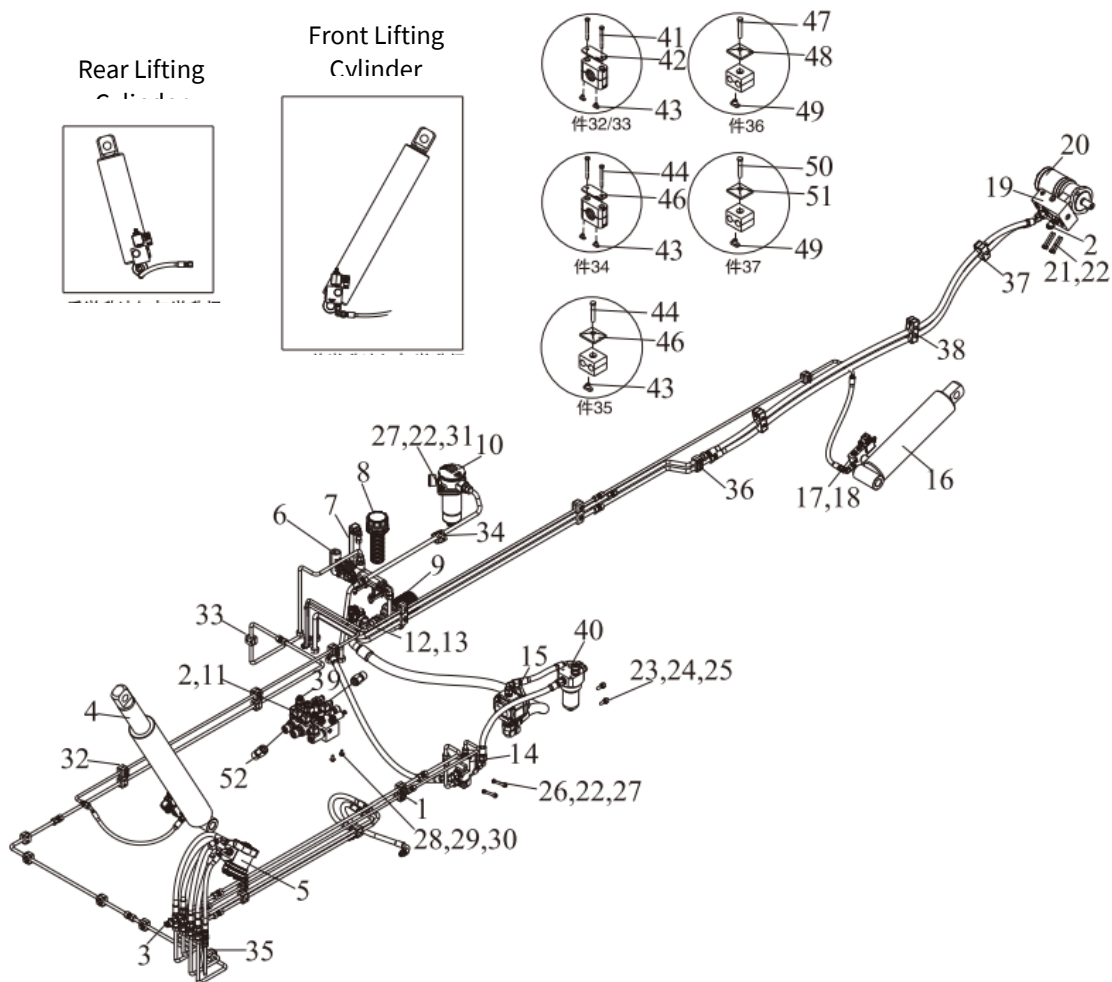

Hydraulic System - Exploded Parts View

Hydraulic System – Spare Parts List

Item	Part No.	Description	Qty	Remarks
1		Hydraulic System Piping, complete (NOTE: a complete set of hydraulic piping is NOT available as a replacement part)	1	B80J4-10000
2	PRPW02989	Test Point, Hydraulic, G1/4	2	
3	PRPW02990	Test Point, Hydraulic	1	
4	PRPW02991	Front Hydraulic Lift Cylinder	1	
5	PRPW02992	Steering Unit	1	
6	PRPW03016	Emergency Hydraulic Hand Pump	1	
7		Liquid Level Thermometer	1	HF05-127xM12-1
8		Air Filter	1	HF04-450x10-1
9		Oil Suction Filter	1	PRPW03255
10		Oil Return Filter	1	HF02-120x10-1
11	PRPW02331	Hydraulic Control Valve, Belt Deck Lifting	1	
12		Gate Valve	1	GV13-25-ZG1-1
13		Transition Joint	1	GJT-1TH-16-33OG
14	PRPW02996	Priority Valve	1	
15	PRPW00027	Gear Pump	1	
16	PRPW02998	Oil Cylinder	1	
17		Lifting solenoid Valve Group	2	HV02-60-S-1
18	PRFA00284	Bolt, Hinged, for Solenoid Valve Assembly	2	
19	PRPW03000	Balance Valve	1	
20	PRPW03001	Hydraulic Motor	1	
21	PRFA00285	Screw, Hex Socket Head Cap, M8 x 60 mm	4	
22	PRFA00010	Washer, Lock, M8	6	
23	PRFA00008	Bolt, M10 x 30 mm	2	
24	PRFA00012	Washer, Lock, M10	2	
25	PRFA00011	Washer, Flat, M10	2	
26	PRFA00286	Bolt, M8 x 60 mm	2	
27	PRFA00009	Washer, Flat, M8	4	
28	PRFA00001	Bolt, M6 x 20 mm	4	
29	PRFA00007	Washer, Lock, M6	4	
30	PRFA00006	Washer, Flat, M6	4	

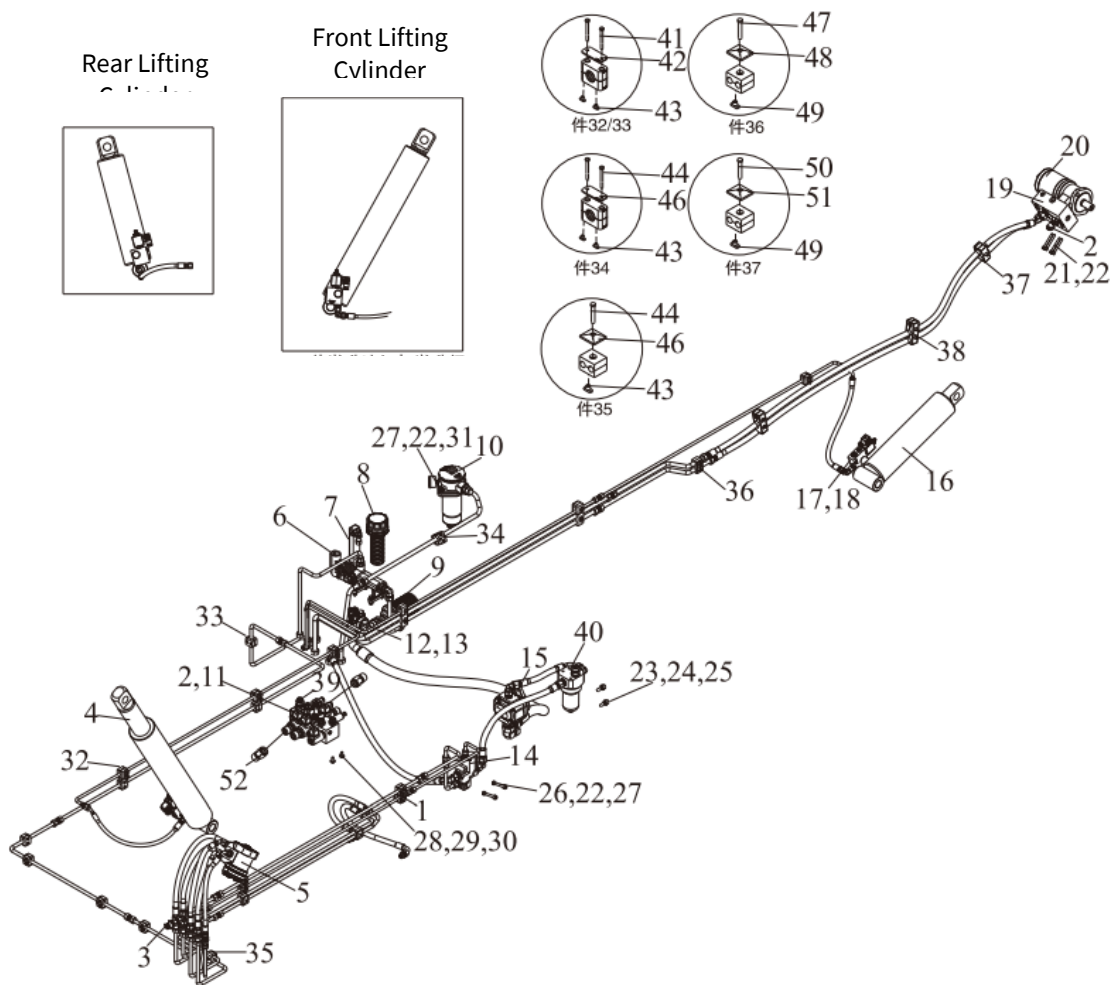

Hydraulic System - Exploded Parts View

Hydraulic System – Spare Parts List

Item	Part No.	Description	Qty	Remarks
31	PRFA00047	Bolt, M8 x 35 mm	2	
32	PRPW03003	Pipe Clamp, Single, M10	10	
33	PRPW03004	Pipe Clamp, Single, M12	11	
34	PRPW03005	Pipe Clamp, Single, M15	1	
35	PRPW03002	Pipe Clamp, Double, M12	4	
36	PRPW03006	Pipe Clamp, Double, M15	3	
37	PRPW03007	Pipe Clamp, Triple, M21.3	1	
38	PRPW03008	Pipe Clamp	4	
39	PRPW03009	Check Valve	1	
40	PRPW02715	High Pressure Filter	1	
41	PRFA00115	Bolt, M6 x 30 mm	42	With Pipe Clamp
42		Locking Plate	21	TL-G1 With Pipe Clamp
43		Nut, M6	52	TL-F With Pipe Clamp
44		Bolt, M6 x 35 mm	6	GB/T 5783 With Pipe Clamp
45		Locking Plate	1	TL-G2 With Pipe Clamp
46		Locking Plate	4	TT-G1 With Pipe Clamp
47	PRFA00047	Bolt, M8 x 35 mm	3	With Pipe Clamp
48		Locking Plate	3	TT-G2 With Pipe Clamp
49		Nut, M8	4	TT-F With Pipe Clamp
50	PRFA00257	Bolt, M8 x 45 mm	1	With Pipe Clamp
51		Locking Plate	1	TT-G3 With Pipe Clamp
52		Emergency Knob	2	B80Y4-00004

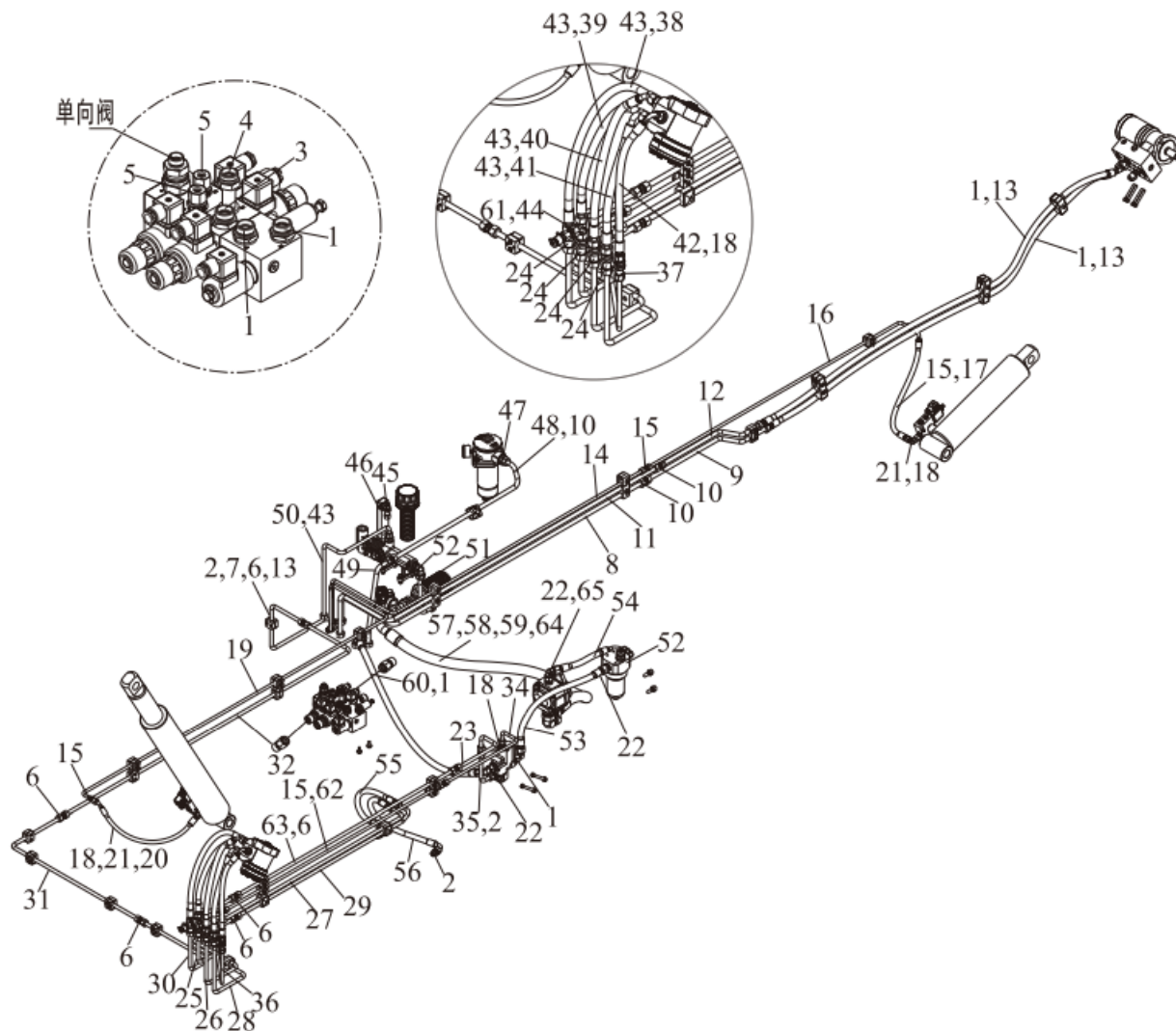

Hydraulic Piping - Exploded Parts View

Hydraulic Piping – Spare Parts List

Item	Part No.	Description	Qty	Remarks
1	PRPW03020	Hydraulic Stud Fitting Adapter, Metric to BSP with captive seal, metric thread M22 x 1.5, BSP thread G1/2 in. x 14, pipe o.d. 15 mm	4	
2	PRPW03021	Hydraulic Stud Fitting Adapter, Metric to BSP with captive seal, metric thread M18 x 1.5, BSP thread G3/8 in. x 19, pipe o.d. 12 mm	3	
3	PRPW03022	Hydraulic Stud Fitting Adapter, Metric to BSP with captive seal, metric thread M22 x 1.5, BSP thread G3/8 in. x 19, pipe o.d. 15 mm	1	
4	PRPW03023	C, Metric to BSP with captive seal, metric thread M22 x 1.5, BSP thread G3/8 in. x 19, pipe o.d. 15 mm, Special Length 66.5 mm	1	
5	PRPW03024	Hydraulic Stud Fitting Adapter, Metric to BSP with captive seal, metric thread M16 x 1.5, BSP thread G3/8 in. x 19, pipe o.d. 10 mm	2	
6	PRPW03025	Hydraulic Adapter, Straight, male M18 x 1.5 to male M18 x 1.5	8	
7	PRPW03026	Hydraulic Adapter, 90-Degree Elbow, Compression Metric Fitting, female to male, thread M18 x 1.5, for pipe o.d. 12 mm	1	
8	PRPW03027	Pipe Assembly, Steel	1	
9	PRPW03031	Pipe Assembly, Steel	1	
10	PRPW03029	Hydraulic Adapter, Straight, male M22 x 1.5 to male M22 x 1.5	3	
11	PRPW03030 or PRPW03033	Pipe Assembly, Steel	1	
12	PRPW03031	Pipe Assembly, Steel	1	
13	PRPW03032	Hose, Hydraulic	2	
14		Pipe Assembly, Steel	1	B80X4-10004
15	PRPW03034	Hydraulic Adapter, Straight, male M16 x 1.5 to male M16 x 1.5	5	
16	PRPW03035	Pipe Assembly, Steel	1	
17	PRPW03036	Hose, Hydraulic	1	
18	PRPW03037	Hydraulic Stud Fitting Adapter, Metric to BSP with captive seal, metric thread M16 x 1.5, BSP thread G1/4 in. x 19, pipe o.d. 10 mm	4	
19	PRPW03038	Pipe Assembly, Steel	1	
20	PRPW03039	Hose, Hydraulic	1	
21	PRPW03040	Hydraulic Adapter, 90-Degree Elbow	2	

BL30D Belt Loader

22	PRPW03041	Hydraulic Adapter, 90-Degree Elbow, Compression Metric Fitting, female to male, thread M22 x 1.5, for pipe o.d. 15 mm	2	
23	PRPW03042	Pipe Assembly, Steel	1	
24	PRPW03043	Hydraulic Bulkhead Adapter, metric, 24-degree cone, M18 x 1.5, for pipe o.d. 12 mm	4	
25	PRPW03044	Pipe Assembly, Steel	1	
26	PRPW03045	Pipe Assembly, Steel	1	
27	PRPW03046	Pipe Assembly, Steel	1	
28	PRPW03047	Pipe Assembly, Steel	1	
29	PRPW03048	Pipe Assembly, Steel	1	
30	PRPW03049	Pipe Assembly, Steel	1	
31	PRPW03050	Pipe Assembly, Steel	1	
32	PRPW03051	Pipe Assembly, Steel	2	

PAGE INTENTIONALLY LEFT BLANK

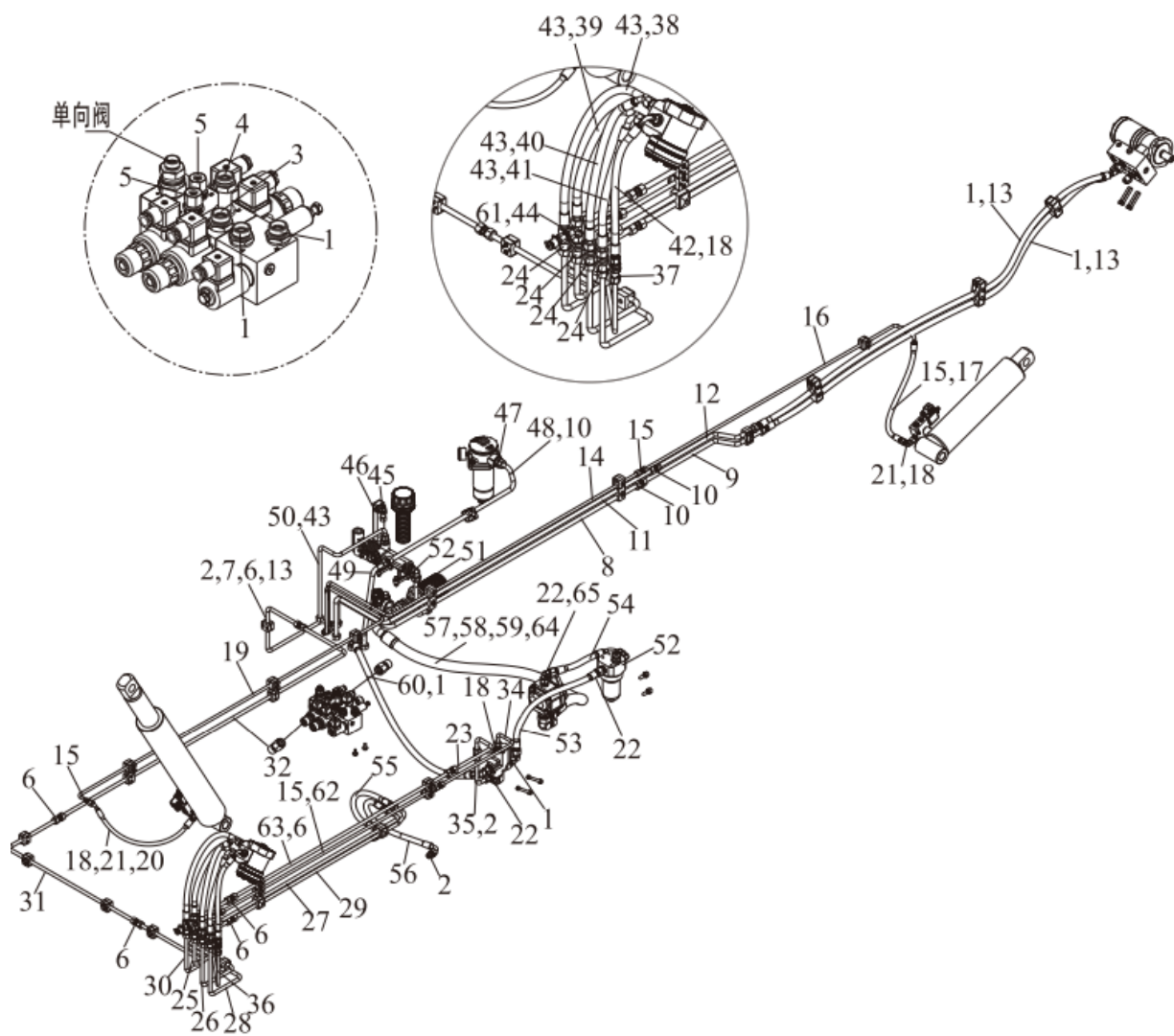

Hydraulic Piping - Exploded Parts View

Hydraulic Piping – Spare Parts List

Item	Part No.	Description	Qty	Remarks
33	PRPW03052	Pipe Assembly, Steel	1	
34	PRPW03053	Pipe Assembly, Steel	1	
35	PRPW03054	Pipe Assembly, Steel	1	
36	PRPW03055	Pipe Assembly, Steel	1	
37	PRPW03056	Hydraulic Bulkhead Adapter, metric, 24-degree cone, M16 x 1.5, for pipe o.d. 10 mm	1	
38	PRPW03057	Hose, Hydraulic	1	
39	PRPW03058	Hose, Hydraulic	1	
40	PRPW03059	Hose, Hydraulic	1	
41	PRPW03060	Hose, Hydraulic	1	
42	PRPW03061	Hose, Hydraulic	1	
43	PRPW03062	Hydraulic Stud Fitting Adapter, Metric to BSP with captive seal, metric thread M18 x 1.5, BSP thread G1/2 in. x 14, pipe o.d. 12 mm	5	
44	PRPW03063	Tee Joint, Hydraulic, with swivel nut, metric, M18 x 1.5, for pipes o.d. 12 mm	1	
45	PRPW03064	Hydraulic Adapter, 90-Degree Elbow, High Pressure, Metric, thread M18 x 1.5, for pipes o.d. 10 mm	1	
46	PRPW03065	Plug, Hydraulic, Metric, thread M16 x 1.5 mm	1	
47	PRPW03066	Hydraulic Stud Fitting Adapter, Metric to BSP with captive seal, metric thread M22 x 1.5, BSP thread G3/4 in. x 14, pipe o.d. 15 mm	1	
48	PRPW03067	Pipe Assembly, Steel	1	
49	PRPW03068	Pipe Assembly, Steel	1	
50	PRPW03069	Pipe Assembly, Steel	1	
51	PRPW03070	Pipe Assembly, Steel	2	
52	PRPW03071	Hydraulic Adapter, 90-Degree Elbow, Metric to BSP with captive seal, metric thread M22 x 1.5, BSP thread G1/2 in. x 14	1	
53	PRPW03072	Hose, Hydraulic, High-pressure	1	
54		High Pressure Hose	1	TGLFII-13033-H40.5*J
55	PRPW03074	Hose, Hydraulic	1	

BL30D Belt Loader

56	PRPW03075	Hose, Hydraulic	1	
57	PRPW03076	Hose, Hydraulic	1	
58	PRPW03077	Hydraulic Pump Adapter, Metric to BSPT male, metric thread M36 x 2.0, BSPT thread 1 in. x 11	1	
59	PRPW03078	Hydraulic Adapter, 45-Degree Elbow, Metric to BSP with captive seal, metric thread M36 x 2.0, BSP thread G1 in. x 11	1	
60	PRPW03079	Hose, Hydraulic	1	
61	PRPW03080	Hydraulic Reducer Tube Adapter with swivel nut, Metric, threads M16 x 1.5 to M18 x 1.5	1	
62	PRPW03081	Pipe Assembly, Steel	1	
63	PRPW03082	Pipe Assembly, Steel	1	
64		Elbow	1	GJT-2C9-36W
65		Elbow	2	GJT-2C9-22W

PAGE INTENTIONALLY LEFT BLANK

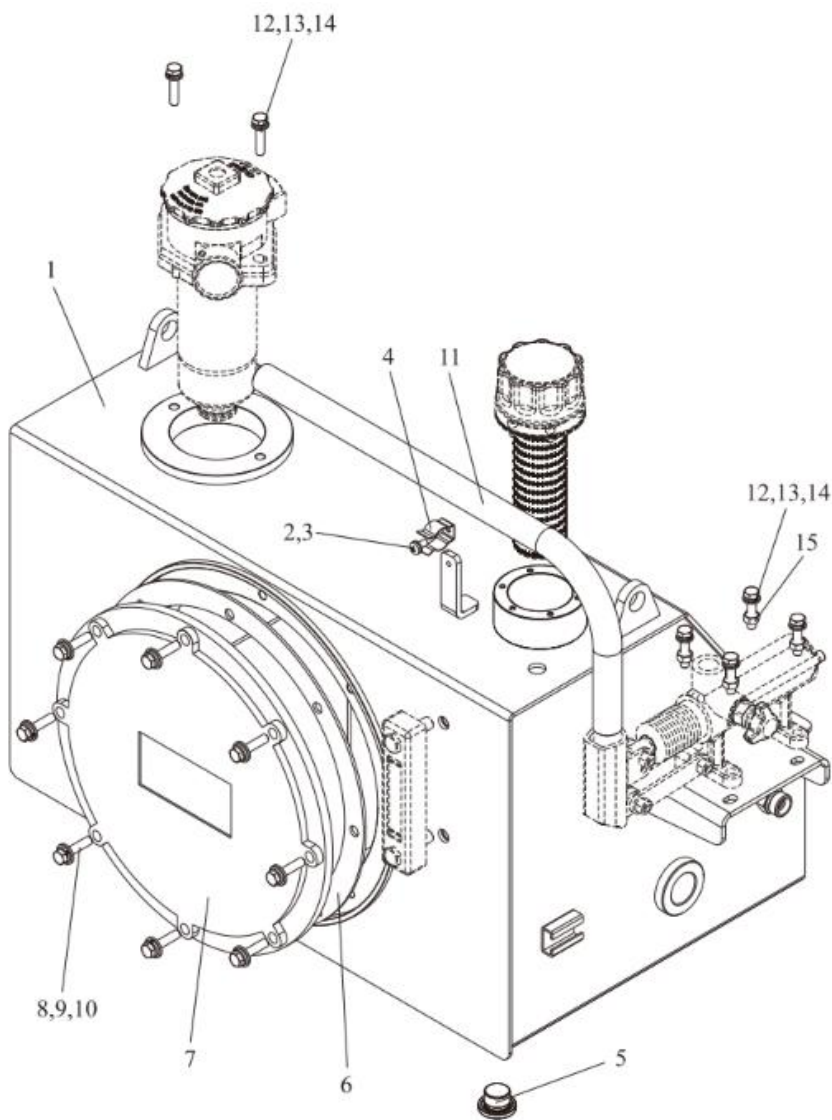

Hydraulic Oil Tank - Exploded Parts View

Hydraulic Oil Tank – Spare Parts List

Item	Part No.	Description	Qty	Remarks
1	PRPW03010	Oil Tank, Welded	1	
2		Screw, M6 x 12 mm	1	GB/T 818
3	PRFA00006	Washer, Flat, M6	1	
4	PRPW03013	Pipe Clamp	1	
5	PRPW00751	Plug, Drain	1	
6		Clean The Cover Gasket	1	YG-350-M
7	PRPW03019	Access Cover	1	
8	PRFA00026	Bolt, M10 x 35 mm	8	
9	PRFA00012	Washer, Lock, M10	8	
10	PRFA00011	Washer, Flat, M10	8	
11	PRPW03014	Lever	1	
12	PRFA00047	Bolt, M8 x 35 mm	6	
13	PRFA00010	Washer, Lock, M8	6	
14	PRFA00009	Washer, Flat, M8	6	
15	PRFA00021	Nut, M8	4	

WHEELS & TIRES

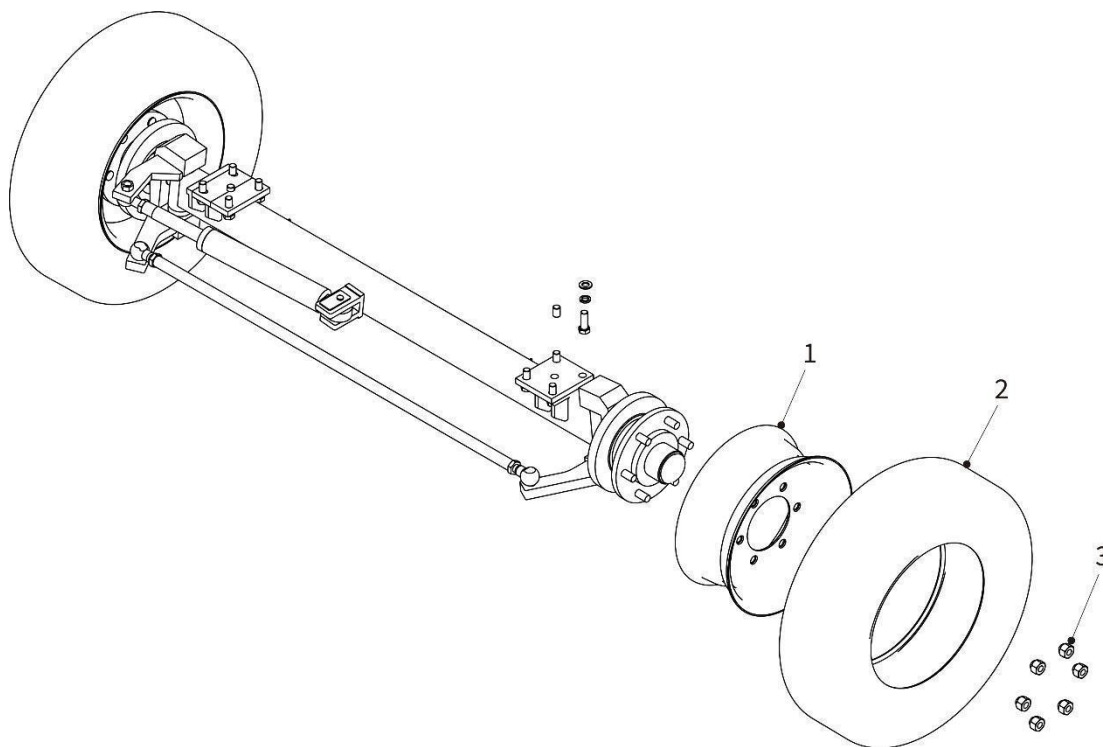

Front Wheels and Tires - Exploded Parts View

Front Wheels and Tires – Spare Parts List

Item	Part No.	Description	Qty	Remarks
1	PRPW02746	Tire Rim, 6J x 15	2	
2	PRPW03085	Tire, 225/70R15	2	
3	PRPW02949	Wheel Nut, M18	12	

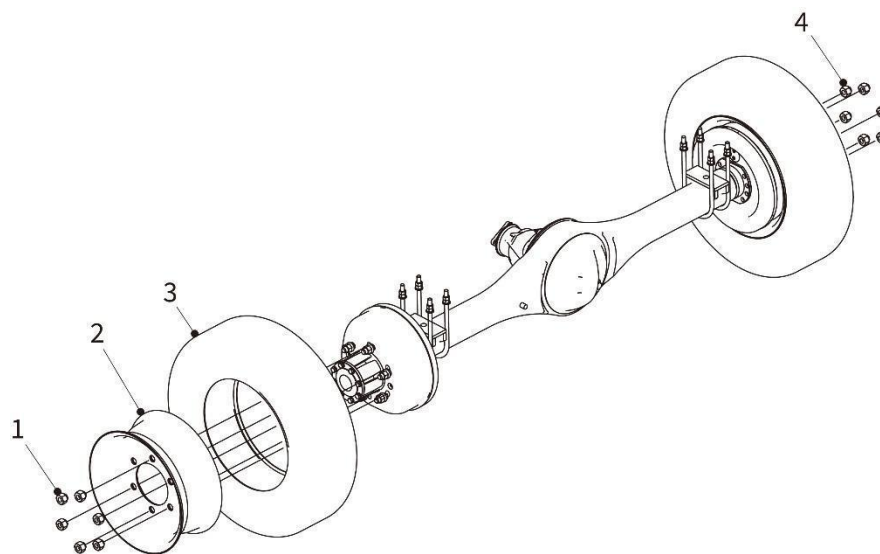

Rear Wheels and Tires - Exploded Parts View

Rear Wheels and Tires – Spare Parts List 1

Item	Part No.	Description	Qty	Remarks
1	PRPW02947	Wheel Nut, M18 x 25 mm, Left-hand thread	6	
2	PRPW02746	Tire Rim, 6J x 15	2	
3	PRPW03089	Tire, 225/70R15	2	
4	PRPW02949	Wheel Nut, M18 x 25 mm, Right-hand thread	6	

Labels – Spare Parts List

Item	Part No.	Description	Qty	Remarks
1	PRPW02758	BL30D Warning Labels for Printing (A complete set of labels for the BL30D)	1	

PAGE INTENTIONALLY LEFT BLANK

SUPPLEMENTARY INFORMATION

LIFTING/SHIPPING THE BL30D BELT LOADER

When lifting the Belt Loader, ALWAYS use a crane and a four-leg lifting sling or chain, as shown in the Lifting Diagram below. The Safe Working Load (SWL), also known as Rated Capacity, of the crane and four-leg lifting sling or chain MUST be at least 7000 kg (7 Tons).

ALWAYS attach the lifting sling or chain to the four lifting points provided on the Belt Loader, as shown in the lifting diagram, below.

NEVER attempt to lift the BL30D using a forklift. The length and design of the BL30D makes it an unstable load on a forklift. Also, there are NO bearing plates on the underside of the BL30D suitable for engaging the forks of a forklift.

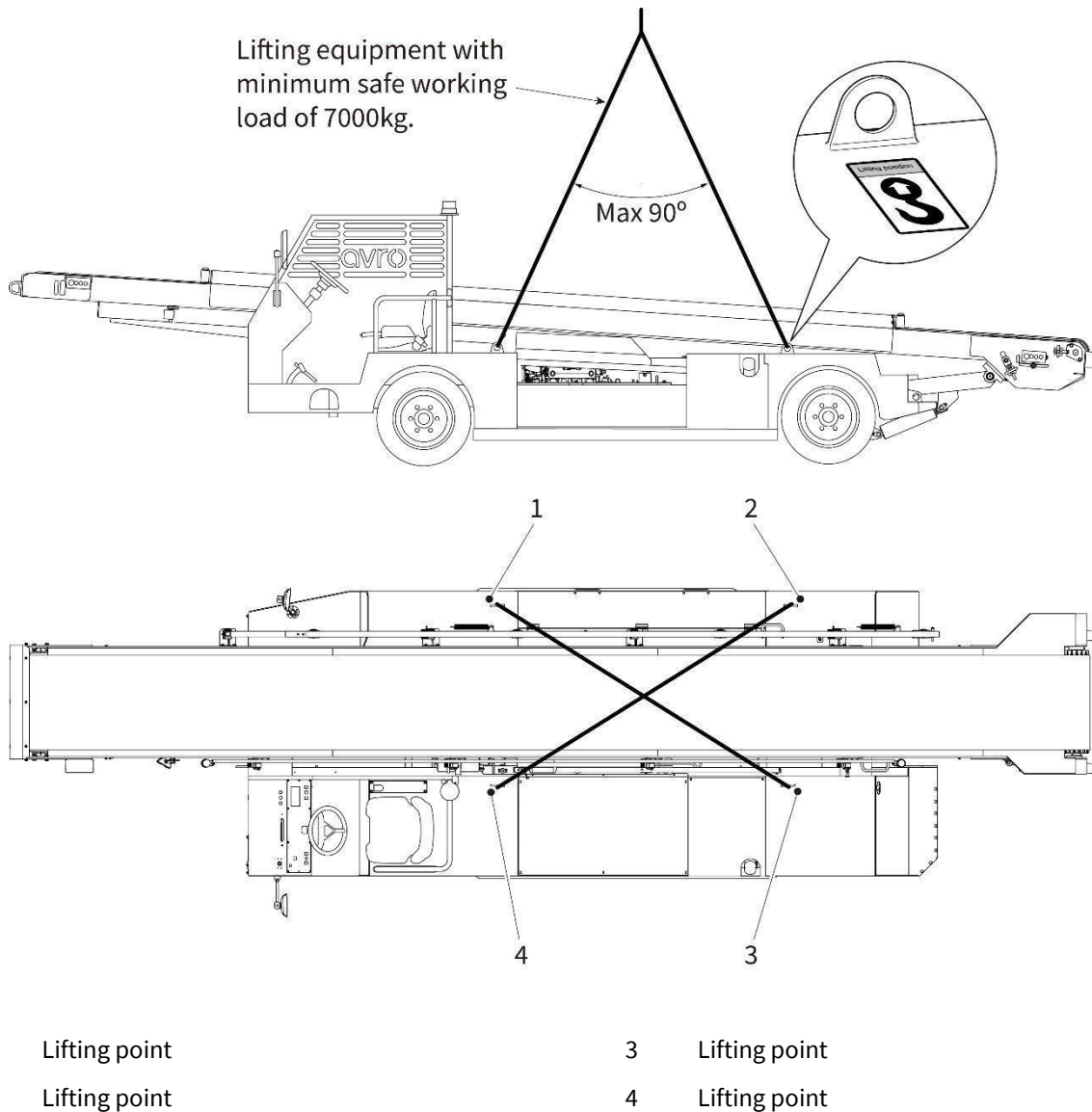

Figure 24 - Lifting diagram

WARNING – SIZE AND WEIGHT OF BELT LOADER



The Belt Loader is 8.1 m (26 ft 6.9 in.) long and weighs 4200 kg (9260 lbs). When lifting the Belt Loader, always use a crane and a four-leg lifting sling or chain with a Safe Working Load (SWL) of at least 7000 kg (7 Tons). Always attach the four leg lifting sling or chain to the four lifting points on the Belt Loader.

Before commencing a lifting operation, make sure that:

- (1) The lifting equipment is in good condition. Do not use lifting equipment whose condition is suspect.
- (2) The lifting equipment has been regularly inspected, maintained, and certified, in accordance with the applicable National and Local regulations and codes. Do not use lifting equipment that does not meet this requirement, or which has exceeded the mandated time between inspections.

- (3) On the Belt Loader, the Belt Frame is in the fully lowered position.

The Belt Loader must always be towed or moved using a suitable vehicle.

WARNING – LIFTING OPERATIONS



Lifting operations must ONLY be done by personnel who are trained and authorised to perform lifting operations.

DO NOT reach or stand beneath a Belt Loader that is suspended by a crane.

Wear a hard hat, high visibility clothing, and suitable footwear during lifting operations.

WARNING – DO NOT LIFT A BELT LOADER WITH A FORKLIFT



The Belt Loader is 8.1 m (26 ft 6.9 in.) long and weighs 4200 kg (9260 lbs). Due to the length and shape of the Belt Loader, DO NOT use a forklift truck to lift the Belt Loader.

The Belt Loader is not designed to be lifted with a forklift.

Before lifting the Belt Loader, make sure that the Belt Frame is in the fully lowered position. Having the Belt Frame in the fully lowered position will reduce the instability of the load. If necessary, use the emergency procedures to lower the Belt Frame.

When lifting the Belt Loader, observe ALL the safety precautions specified in this section of the manual.

WARRANTY

All Avro GSE products are covered by our Warranty Policy. If you require a copy of our Warranty Policy, please contact us using the contact details given on page 2 of this manual.

DISPOSAL

The BL30D Belt Loader contains electrical components, including a vehicle battery. A Belt Loader that is damaged beyond economic repair, or worn out, should be recycled at a metal recycling facility.

APPENDICES

OKAMURA TRANSMISSION SERVICE MANUAL – Y43340D, Y43290D, AND Y43370D



XT560G Belt loader

Published in Canada by Avro GSE™ Limited.

Back Cover